



LONG TERM INTEGRITY OF CO₂ STORAGE – WELL ABANDONMENT

Technical Study

Report No. 2009/08

November 2009

*This document has been prepared for the Executive Committee of the IEA GHG Programme.
It is not a publication of the Operating Agent, International Energy Agency or its Secretariat.*

INTERNATIONAL ENERGY AGENCY

The International Energy Agency (IEA) was established in 1974 within the framework of the Organisation for Economic Co-operation and Development (OECD) to implement an international energy programme. The IEA fosters co-operation amongst its 26 member countries and the European Commission, and with the other countries, in order to increase energy security by improved efficiency of energy use, development of alternative energy sources and research, development and demonstration on matters of energy supply and use. This is achieved through a series of collaborative activities, organised under more than 40 Implementing Agreements. These agreements cover more than 200 individual items of research, development and demonstration. The IEA Greenhouse Gas R&D Programme is one of these Implementing Agreements.

ACKNOWLEDGEMENTS AND CITATIONS

This report was prepared as an account of the work sponsored by the IEA Greenhouse Gas R&D Programme. The views and opinions of the authors expressed herein do not necessarily reflect those of the IEA Greenhouse Gas R&D Programme, its members, the International Energy Agency, the organisations listed below, nor any employee or persons acting on behalf of any of them. In addition, none of these make any warranty, express or implied, assumes any liability or responsibility for the accuracy, completeness or usefulness of any information, apparatus, product of process disclosed or represents that its use would not infringe privately owned rights, including any parties intellectual property rights. Reference herein to any commercial product, process, service or trade name, trade mark or manufacturer does not necessarily constitute or imply any endorsement, recommendation or any favouring of such products.

COPYRIGHT

Copyright © IEA Environmental Projects Ltd. (Greenhouse Gas R&D Programme) 2008.

All rights reserved.

ACKNOWLEDGEMENTS AND CITATIONS

This report describes research sponsored by the IEA Greenhouse Gas R&D Programme. This report was prepared by:

TNO, Utrecht, The Netherlands

The principal researchers were:

- T. Benedictus, TNO,
- M.D.C. van der Kuip, TNO
- R.A. Kronimus, TNO,
- J.N. Huibregtse, TNO,
- F. Yavuz, TNO,
- G. Remmelts, TNO,
- J.C. Stam, HPT Laboratory, Faculty of Geosciences, Utrecht University.

To ensure the quality and technical integrity of the research undertaken by the IEA Greenhouse Gas R&D Programme (IEA GHG) each study is managed by an appointed IEA GHG manager. The report is also reviewed by a panel of independent technical experts before its release.

The IEA GHG managers for this report were: Toby Aiken & Neil Wildgust

The expert reviewers for this report:

- Theresa Watson, T.L. Watson & Associates, Canada,
- Stefan Bachu, ARC, Canada,
- Bill Carey, Los Alamos National Laboratory, USA,
- Rick Chalaturnyk, University of Alberta, Canada,
- Mike Celia, Princeton University, USA,
- Walter Crow, BP, USA

The report was also presented and reviewed at the 5th Meeting of the IEA GHG International Research Network on Wellbore Integrity, and the IEA Greenhouse Gas R&D Programme would also like to thank the input from delegates of this meeting.

The report should be cited in literature as follows:

IEA Greenhouse Gas R&D Programme (IEA GHG), “Long Term Integrity of CO₂ Storage – Well Abandonment”, 2009/08, July 2009.

Further information or copies of the report can be obtained by contacting the IEA Greenhouse Gas R&D Programme at:

IEA Greenhouse Gas R&D Programme, Orchard Business Centre,
Stoke Orchard, Cheltenham, Glos., GL52 7RZ, UK
Tel: +44 1242 680753 Fax: +44 1242 680758
E-mail: mail@ieaghg.org
www.ieagreen.org.uk



LONG TERM INTEGRITY OF CO₂ STORAGE – WELL ABANDONMENT

Background to the Study

CO₂ geological storage projects will likely incorporate a range of well types, from injection and production wells, to abandoned and previously completed wells. While newly drilled and completed wells are likely to be governed by and subject to regulations designed to uphold the integrity of storage sites, wells completed and abandoned in the past may have been subject to less strict governance, and it is these wells that are, therefore, considered to be the greater threat to long-term storage integrity.

The IEA Greenhouse Gas R&D Programme (IEA GHG) recently commissioned TNO in The Netherlands to conduct a review of abandonment procedures and methodologies from around the world in order to determine whether the predominant factor influencing the methods used is regional location and regulatory led, or if it is purely down to operator preference.

Storage in deep saline aquifers may be considered as a lower risk, as the number of wellbores expected to be encountered during a storage project should often be lower than those encountered in oil and gas fields. Depleted oil and gas reservoirs are likely to incorporate a greater number of wells perforating the caprock of the reservoir due to the historical exploration and exploitation of these fields.

While the historical exploration of oil and gas fields creates the very potential for geological storage of CO₂ to take place in these reservoirs, it may have given rise to the greatest risk to the storage operation by providing multiple pathways for injected CO₂ to migrate through wellbores to overlying, unbounded geological areas, or ultimately to the atmosphere. This study aims to address this issue, assessing the state of knowledge and identifying methodologies and best practices designed to minimise risks associated with injection into previously drilled and explored areas both on and off-shore.

Seepage, migration and leakage¹ can occur through faults and fractures in the caprock above the storage reservoir, and through poorly completed or abandoned wellbores from previous exploitation or exploration. While site selection criteria should work to minimise the risks posed by faults and fractures, a good understanding of well abandonment and remedial measures necessary to ensure secure storage is necessary to provide assurance to regulators and the general public that CCS is a safe option for greenhouse gas mitigation.

¹ For the context of IEA GHG studies, CO₂ escaping from the storage reservoir is termed seepage, movement through overlying strata and along abandoned wellbores is termed migration, and leakage is the escape of CO₂ from the subsurface to the atmosphere.



Results and Discussion

A Review of Well Plugging and Abandonment Techniques

The report includes a high-level review of the variety of techniques that are employed around the world to facilitate well abandonment. The report describes the preliminary work necessary, such as removal of equipment from the well and cleanout of the wellbore before plugging can take place. The report outlines the basic principles involved in each plugging method and highlights the drawbacks and limitations of the methods. These are summarised in table 1 below.

Abandonment Method	Description	Benefits / Limitations
Balanced Plug ²	The more common method of abandonment, whereby the tubing is placed at the target plug depth, and the cement slurry is then injected onto a bridge plug device which forms the plug base. Cement is then pumped into the annulus until it is equal to the level inside the casing.	One of the simplest techniques, incurring lower costs than some, the main limitation is caused by the potential for cement contamination. This can be minimised by use of best practice and best suited plug base materials, as described later in this overview.
Cement Squeeze	Squeeze cementing involves pressurised forcing of cement at a pre-determined depth coinciding with perforations in the casing. The pressure forces the liquid of the slurry into the formation, leaving the cement to form a seal.	Often used as a remedial measure for flawed or damaged primary cement, the exact quantity of cement required cannot always be calculated, leading to possible excess cement which can enter the casing above the packer. This would effectively stick the tubing into the hole, preventing future removal.
Dump Bailer ³	A known quantity of cement is lowered into the wellbore on a wireline, and the bailer is activated when it reaches the correct position, just over the bridge plug and raising the bailer releases the cement.	The stationary nature of the slurry during the descent can lead to premature setting, so this is more suited to setting plugs at shallower depths
Two-plug	A complex process whereby a top and bottom plug are set at calculated depths, the lower plug cleans the well as it is lowered, and the cement can then be placed with minimal contamination from other fluids.	Allows maximum accuracy of placement with minimum cement contamination. The isolation of the cement slurry from other fluids ensures predictable cement performance.

Table 1: Description of abandonment methods

² A plug is a mechanism whereby a quantity of cement or other mechanical plug effectively seals the wellbore at a given height, isolating permeable layers of the geological formation from each other, preventing migration of injected CO₂.

³ A dump bailer is a tool that delivers a prescribed quantity of cement that can be lowered into the well by a wireline and deployed on top of the permanent plug.



Case Studies

The study covered case studies of abandonment practices at three locations around the world:

- Proposed storage of CO₂ in the depleted De Lier field, The Netherlands,
- Well evaluation at Gulf Coast and SACROC, Texas, USA,
- The Alberta Basin, Alberta, Canada.

These case studies present a range of aspects of wellbore integrity, and the potential impact these have on storage operations.

De Lier field, The Netherlands

The De Lier case illustrated several concerns that are often raised when considering second life applications for depleted hydrocarbon fields. The integrity of the previously abandoned wells gave rise to health, safety and environmental concerns, often a consideration when dealing with second life applications.

The De Lier study provides a good example of the implications of regulatory regimes. Of the 51 abandoned wells, 3 were abandoned before 1967 when regulations were enforced. These wells are typified by significantly shorter cement plugs than current standards recommend, despite conforming to the Dutch Mining Regulations and Decree with regard to isolation of the low pressure depleted gas reservoir.

The stacked nature of the De Lier field adds complexities to proposed storage, as many wells transect the proposed storage reservoir, and due to the methods prevalent at abandonment, no cement plugs are present at the caprock level. The abandonment status alone is unlikely to present the potential for gas migration to the surface, but if corrosive fluids were introduced additional abandonment measures would be needed.

Additional issues were encountered due to urban and industrial development over and around abandoned wellbores, presenting accessibility issues for monitoring and any necessary recompletion.

Following the well evaluations, storage in the De Lier field was not considered economically feasible – expensive work-over measures would be required on numerous wells to safeguard CO₂ storage satisfactorily.

Gulf Coast and SACROC, Texas, USA

Texas is an area often used as a case study for CO₂ storage due to the high number of abandoned wells, and the history of hydrocarbon exploitation and production. Here the issues are with well densities, and completion methods. Many wells were completed before 1930, and were not plugged with cement and abandonment methods were not subject to governance by the site operators. These wells are known as ‘orphan wells’⁴. Other political influences have made the area a popular case study, including the oil crisis in the mid 1980’s where many deeper wells were not plugged with cement due to operator companies becoming insolvent. Data quality is identified as another issue, with the exact details of many wells being unknown, or of poor quality.

Field samples from wellbores comprising of steel casing and portions of cement obtained from the SACROC (see figure 1) region have been vigorously studied and make a strong case for the

⁴ An orphan well is classified as a well that is not abandoned adequately and no longer falls under the jurisdiction of the operating company.

argument of using Portland⁵ cements. On obtaining samples, it appears that the wells were completed using a neat Portland cement which has served to prevent degradation of the casing which showed very little evidence of corrosion. There are however clear signs of cement alteration in 2 locations.

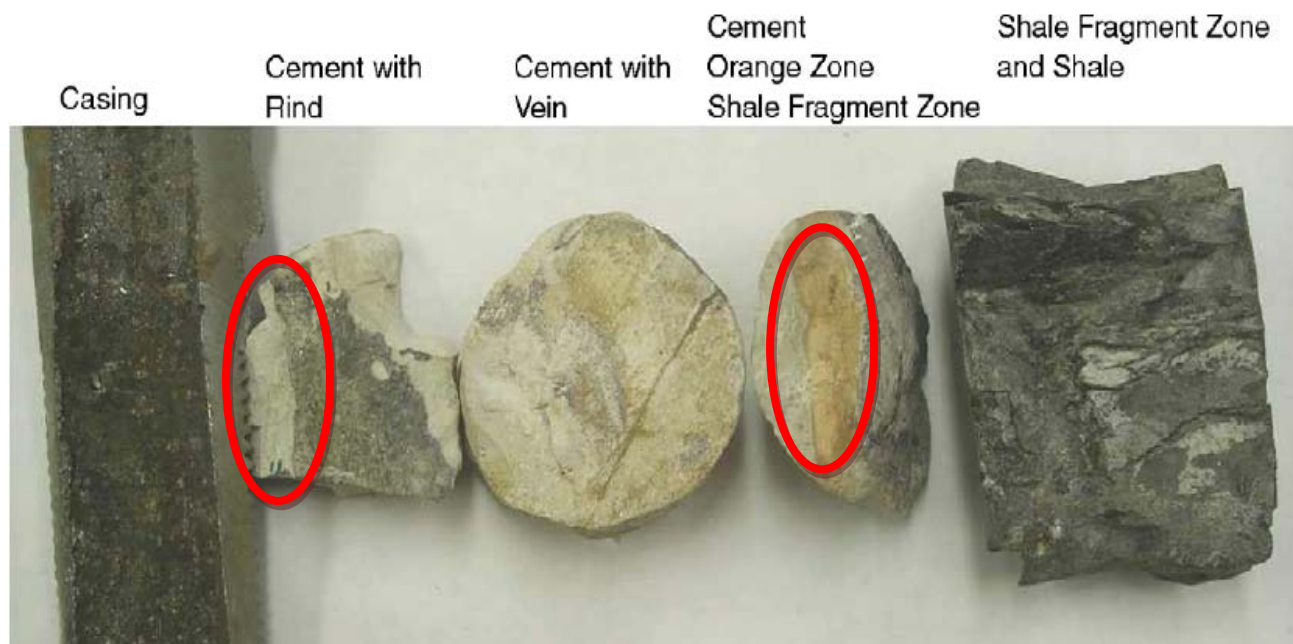

Figure 1: Photograph of samples retrieved from well 49-6, showing (from left to right) casing, cement with alteration zones at both interfaces, a zone of fragmented shale and shale caprock (Carey et al., 2007).

Collaborative studies have determined that the cement in the SACROC sample will have retained its initial structural integrity, and would be suitable for containing injected CO₂ in a storage activity. The sample also shows that migration along interfaces is likely to occur, leading to the alteration zones⁶ evident in figure 1. This suggests that further work is required to maximise the integrity of the interfaces of wellbore completions.

The Alberta Basin, Canada

Alberta is another region that has seen extensive drilling and oil and gas production, but unlike Texas, the Alberta Basin has a very high quality and complete database on oil and gas wells. Similar to many regions of the world, monitoring is required by regulations during a sites active lifetime, but following adequate abandonment, no further monitoring is required.

Again, we see that earlier wells were not required to be cemented to the same standards that later wells were, and this is evident in many older shallower wells having inadequate primary cement sheaths. Sustained casing pressure⁷ has been recorded at various locations from shallow gas resources, and these leakage pathways could present potential pathways for CO₂ migration from lower levels.

⁵ The Portland cement used in this well was Portland Class H cement, with 50% fly ash and 3% Bentonite gel, and a density of 1710kg/m³, from Crow et al., 2008.

⁶ The alteration zones are shown as the areas with a colour change from the adjacent area. This is due to carbonation of the minerals in the cement. In this image, the alteration zones are seen on the left-hand edge of the left hand cement sample as a white rind, and as the orange area on the right-hand cement sample, both indicated by the red circles.

⁷ Sustained casing pressure is a term used, mainly in Canada, to describe the increase in pressure and subsequent leakage at the surface of a wellbore following migration of CO₂ along the wellbore.



Extensive reviews of well failures have been carried out in Alberta, and it is noted that post 1994 well failures are much less frequent due to the improvements in regulatory requirements⁸. The review also highlighted the variation in causes of well failures, from tubing or casing failure, packer failure, zonal isolation failure and sustained casing pressure. These variations represent different aspects of the wellbore suffering failure, with converted wells suffering greater incidences of failure than wells drilled for purpose, again highlighting the influence of regulation on the minimisation of leaks through wellbores.

Regulatory Review

The report also looks at several examples of regulatory regimes in place around the world aimed at controlling CO₂ storage operations and making operators accountable for leakage and problems over the longer site lifetime. Assessment of current regulatory frameworks can help to determine and evaluate initial abandonment practices only, and subsequent changes to legislation mean that during the lifetime of a commercial scale CO₂ storage project it is conceivable that well abandonment practices would change. However, it is also unlikely that regulatory regimes will stipulate the exact abandonment methods for all wells encountered in a field, rather they would allow operators to assess and make informed judgements as to which methods are necessary to fulfil the regulatory requirements, ensure safety, but not entail excessive or prohibitive costs. It is accepted that a site specific survey would be required for each potential storage site, and site selection criteria would likely remove some potential sites from the reckoning due to excessive remedial costs for abandoned wells.

The report looks at 11 different regulatory regimes from European, Australasian and American countries, and also assesses the London Convention and Protocol and the OSPAR Convention, with the role they play as International Conventions.

From this review⁹, it is clear that there is a large repository of regulatory information and tools available to regulators of CO₂ storage activities, and much of this has evolved from the legislation governing well abandonment in the hydrocarbon and petroleum extraction industries.

Generally, the regulations in place provide guidance on abandonment methods for existing wells, and although the review shows that there is always a need for a cement plug, the length of cement plug varies greatly, from a minimum of 15m in Canada, to up to 100m in some European scenarios. Other areas where variation is apparent include verification of abandoned wells, provisions made for CO₂ storage, and data availability.

The single most difficult hurdle encountered by the contractor when assessing international regulatory positions, was the language barrier that exists. Many countries do not offer their regulations in anything but their native language, and any translation is deemed unofficial.

Specific Impacts of CO₂ on Wellbore Integrity

While the similarities between hydrocarbon production and geological storage of CO₂ mean that operators can learn greatly from previous oil and gas industry experience, there are

⁸ This is extrapolated from results showing fewer instances of sustained casing pressure following the introduction of regulations stipulating abandonment methods. Sustained casing pressure is much more likely to be observed in a well lacking in cement, suffering from degradation from formation fluids, deformations or poor cementing procedures.

⁹ It should be noted that this review is not intended to relay information on all regulatory regimes in place globally, rather it should reflect the wide range of legislative tools in place, and likewise, the review is not exhaustive, and there are many other legislator tools in use that are not included in this review.



significant contrasts of discrete characteristics that can have severe implications on wellbore integrity. Such characteristics include re-pressurisation of exploited reservoirs, the need for long-term containment over 1000's of years, and the potential for chemical reactions between aqueous phase CO₂ and formation geology and wellbore materials.

Impacts that must be specifically investigated for CO₂ storage purposes can be classified as:

- ***Mechanical deformation of wellbore cement;***
This is generally caused by operational activities such as drilling new wellbores, and changes in the temperature and pressure cycles. Natural stresses can also occur, and any of these factors can lead to the development of cracks, small or large, or shear strain. Either of these scenarios can create highly permeable pathways for leakage of the injected CO₂.
- ***Chemical degradation of wellbore cement;***
The injected CO₂ will not be corrosive, but when it mixes with formation water, it can form a corrosive form of carbonic acid. This dissolution process and the resulting acid will degrade the solid constituents of the cement to produce carbonates.
- ***Corrosion of the wellbore casing steel;***
Steel corrosion is an electrochemical process, and requires the presence of a cathodic and anodic reaction. The more prevalent conditions in CO₂ storage reservoirs involve the corrosion of iron metals under the influence of dissolved hydrogen ions. Hydrogen gas generated by the cathodic and anodic reactions drives the corrosion process.

Risk Management Methodologies

Risk management is defined in the context of this study as comprising of all the activities involved in assessment, mitigation and monitoring of risks.

Risk management methodologies should include site selection and characterisation, and storage system design. Risk assessment should investigate the likely and actual performance of a storage site over geological time periods. Within the CO₂ storage environment, as an industry very much in the developmental stage, there are many options for risk management, and these can be classified as qualitative or quantitative.

Table 2 below shows the range of well assessment methodologies available, and the aspects they address.



Well Assessment methodology	Qualitative analysis	Quantitative analysis	HSE analysis	Simulator	Decision tool
TNO-CASSIF ¹	FEP-based Scenario Analysis	N/A			X
The Generic CO ₂ Geological Database ²	FEP-based Scenario Analysis	N/A			X
Data mining ³		Semi-quantitative			X
Performance and Risk Management methodology (P&R TM) + Simeo TM -Stor ⁴		Probabilistic	X	X	X
Semi-Analytical Model and Monte Carlo Simulation ⁵		Probabilistic		X	
CO ₂ -PENS ⁶		Probabilistic	X	X	X
¹ TNO; Yavuz et al. (2008) ² Quintessa; Preston et al. (2005) ³ Watson and Bachu (2007) ⁴ Le Guen et al. (2008); Meyer et al. (2008) ⁵ Kavetski et al. (2006) ⁶ Viswanathan et al. (2008); Stauffer et al. (2009)					

Table 2: Characteristics of well assessment methodologies

The report analyses these to some depth to relate a number of well features to the level of impact they pose to the risk of leakage. These are grouped into factors of: no impact, minor impact and major impact. The results of this assessment are summarised in the table below. For full details, see section 6.3 in the main report.



Impact	Factor	Description
No impact	Well age	The expectation of higher leakage rates of older wells due to less elaborate construction and materials was not supported by the data. For example, in Alberta, compulsory testing was not put into place until 1995, very little data is available before this date, resulting into a serious distortion of the analysis of the age factor.
	Well operational mode	The distinction between oil and gas production, water and solvent injection, disposal of liquid waste or acid gas did not reveal any effect with respect to wellbore leakage. Some operational modes were expected to present more impact, but as many wells are still operational, data is again not available.
	Completion interval	Depth of the source of migrated gas and depth of completion intervals revealed no correlation, and this was supported by cement logs and other measured data.
	H ₂ S or CO ₂ presence	The presence of hydrogen sulphide and CO ₂ in produced hydrocarbons was investigated for a possible impact on internal and external casing corrosion, and again, the data did not support this.
Minor Impact	Licensee	Various operators using different abandonment practices may result in different sealing efficiencies of wells subject to abandonment.
	Surface casing depth	Surface casing depth was not found to influence the quantity of leakage, however, there is an influence on whether leakage occurs.
	Total depth	Gas migration increases slightly with total well depth, attributed to the generally increasing un-cemented upper interval of deeper wells, providing enhanced hydraulic communication with source formations.
	Well density	In areas exhibiting high well densities, occurrence of well-to well crossflow can potentially result in enhanced leakage rates of wells. This hypothesis was not supported by the available data but was indicated from other work.
	Topography	River valleys may represent zones of higher leakage risks due to removal of overburden and corresponding decline of hydrostatic pressure, potentially resulting in shallow over-pressured zones.
Major Impact	Geographic area	In certain areas within the province of Alberta testing of all wells is required, whereas in other areas the requirements are less strict. One area within the province subject to testing requirements for all wells exhibited a more frequent occurrence of leakage compared to the entire province. However, it is not clear whether this finding refers to the different testing conditions.
	Wellbore deviation	Migration occurred significantly more often related to deviated wells, while the impact of well deviation on the ratio of leakage to migration was minor.
	Well type	Cased abandoned wells account for 98% of all leakage cases reported. The rest refers to wells drilled and abandoned. This significant difference may rely on more stringent abandonment requirements for drilled and abandoned wells.
	Abandonment Method	In Alberta, cased and completed wells are predominantly abandoned by bridge plugs capped with cement. Based on the data set and experience 10% of these bridge plugs will fail over a period of centuries allowing formation fluids to enter the wellbore.
	Oil prices and regulatory changes	The data set reveals a significant positive correlation between leaks and migration occurrence and oil price between 1973 and 1999. This can be explained by the relation between exploitation activity and equipment availability. Satisfaction of a high demand with limited equipment resources impacts on primary cement placement practices.
	Uncemented casing / hole annulus	A low cement top was found to be the most important indicator for migration and leakage. Low cement top is also the main cause for external casing corrosion.

Table 3: Summary of factors impacting leakage risk.

Recommended Best Practice for Well Abandonment

The recommended best practice for well abandonment with specific focus on long term well storage integrity involves 4 aspects:

- Advanced materials: improvements in the capacity of wellbore sealants to isolate stored CO₂ can be applied during drilling, completion, workover and abandonment operations,
- Reduced cement permeability and reactivity: either by reducing the water to cement ratio or the addition of specialist materials which also allows the slurry density to be adjusted over a range of values.
- Use of non-Portland cements: these are less reactive with wet CO₂, however they are not compatible with Portland cements, and cross-contamination must be avoided. They also entail higher costs than Portland based cements.
- Self healing cements and swelling packers: these contain specific additives that react with the fluids present to effectively block cracks and annuli to prevent flow. Swelling packers are used in case of cement failure – they are designed to swell upon contact with hydrocarbons, water or both.

Carlsen and Abdollahi (2007; In: Randhol et al., 2007) describe a methodology for abandonment that is shown in figure 2 below. The process involves removing the tuber and packer before placing a cement plug at the bottom of the well, and then injecting a specialised fluid into the reservoir to clog the near-well area and displace the CO₂ to minimise contact between CO₂ and wellbore materials. The casing is then milled at the level of the caprock and cement injected into this open section to prevent leakage along micro-annuli between casing and cement elements. The well is then filled with non corrosive completion fluid. If secondary seals are present, then an additional cement barrier should be placed at this point.

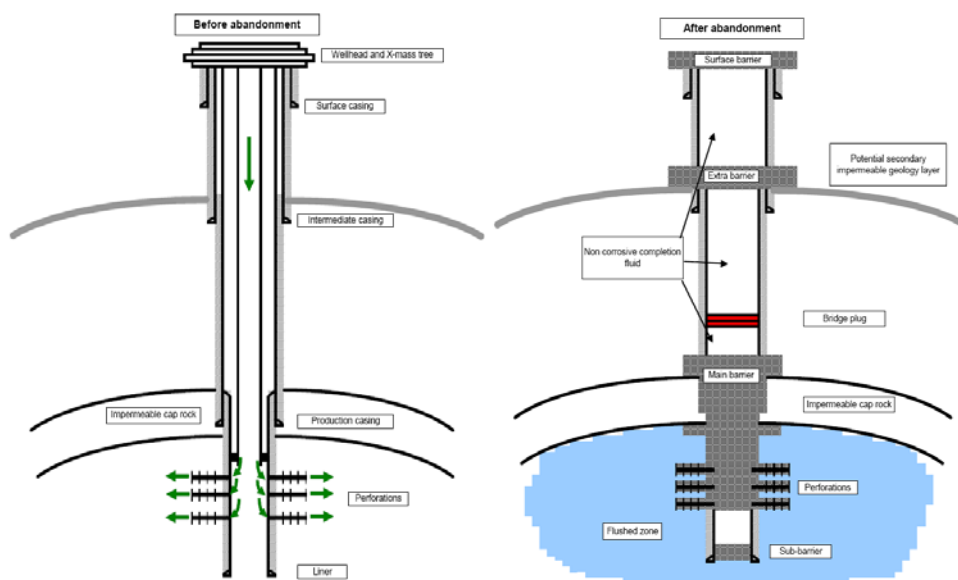

Figure 2: CO₂ storage well before (left) and after abandonment (right) according to the methodology described by Carlsen and Abdollahi (2007; In: Randhol et al., 2007).



Expert Review Comments

Comments were received from numerous expert reviewers, and the feedback was both constructive and supportive of the work that had been carried out. The initial feedback led to a further amendment of the report, which was well received by were met with positivity from the Further comments on the revised report were then incorporated into the final report.

The draft report was presented to the 5th Meeting of the IEA GHG International Research Network on Wellbore Integrity (as a work in progress) in order to provide a thorough review process, and to ensure that the report was critically assessed before being published. Many comments were made at this stage and discussions raised some points for clarification and amendment. Following these amendments, the report was well received, and represents an unbiased view of the problems faced by CO₂ storage CCS projects and reviews the options available to overcome such problems.

Conclusions

The study references work carried out by Watson & Bachu, 2007, that states that wells can be classified as either existing or future wells. Existing wells are further sub-categorised as abandoned or operational, effectively giving 3 well categories: abandoned, operational and future wells, and this classification is key to understanding and rationalising the risks posed to a field during the initial screening process.

The report demonstrates that there is much experience gained through previous pilot and demonstration operations, and that there is a great deal of knowledge on various abandonment techniques that have been proved suitable for CO₂ storage purposes. Recognition of this knowledge is not always evident, and in communicating with regulators and the general public, this level of understanding and confidence should be expressed. This assessment demonstrates this comprehensive range of techniques implicitly, and demonstrates the accepted limitations where relevant.

Due to this knowledge base, future wells can be designed, drilled and abandoned taking into account the CO₂ storage operation, using state-of-the-art technologies. What remains is for regulatory regimes to stipulate clear guidance on recommended best practices within their spheres of influence and operation, facilitating straight-forward start up and initialisation of projects.

One of the most valuable outcomes of the study is the analysis of the risk management methodologies, and this demonstrates that there are a range of methods available, depending on the aim of the assessment, to perform an in-depth analysis of the risks. Alongside this is the analysis of factors affecting well abandonment and the impact they have on the risk of leakage. This analysis will be very useful in the primary stage of a project, in allowing the site characterisation and screening process to be compared with this matrix to determine an overall risk to long term integrity of CO₂ storage.

Recommendations

The contractor recommends in the report that to facilitate international cooperation, all regulations should be provided with an official English language translation, and indeed further discussion should be entered into as to whether such regulations should be freely available for those who wish to read them.



With such a wide range of guidelines and standards, best practice should be clearly defined and stipulated within regulatory instruments to facilitate use of best practice by operators. The study showed that regulations from different regions incorporated many of the same basic elements, but to varying degrees. An example of this is the variation in recommended length of cement plug previously mentioned, stipulating from 15m to 100m in some regions, but the cement plug is a ubiquitous element of abandonment methodology.

It is suggested that all regions and regulatory bodies adhering to the same set of guidelines is unlikely to be realistically practicable, however, all regions with regulatory regimes should clearly stipulate the requirements in their regions, as well as any relevant recommendations for best practice procedures to follow.

If regulatory instruments include best practice recommendations, then it should be possible to make an early assessment of existing wellbores to determine economic feasibility of storage projects by comparing these practices to the initial site characterisation results.



Oil and Gas
Princetonlaan 6
P.O. Box 80015
3508 TA Utrecht
The Netherlands

www.tno.nl

T +31 30 256 42 56
F +31 30 256 44 75
info-BenO@tno.nl

TNO report

TNO-034-UT-2009-01427

Well Abandonment

Long-term integrity for CO₂ storage

Date July 10, 2009

Author(s) T. Benedictus^a
M.D.C. van der Kuip^a
R.A. Kronimus^a
J.N. Huibregtse^a
F. Yavuz^a
G. Remmelts^a
J.C. Stam^b

^a TNO Built Environment and Geosciences, Netherlands

^b HPT Laboratory, Faculty of Geosciences, Utrecht University, Netherlands

Assignor IEA Greenhouse Gas R&D Programme

Project number 034.82150

Number of pages 113

Number of appendices 10

All rights reserved. No part of this report may be reproduced and/or published in any form by print, photoprint, microfilm or any other means without the previous written permission from TNO.

All information which is classified according to Dutch regulations shall be treated by the recipient in the same way as classified information of corresponding value in his own country. No part of this information will be disclosed to any third party.

In case this report was drafted on instructions, the rights and obligations of contracting parties are subject to either the Standard Conditions for Research Instructions given to TNO, or the relevant agreement concluded between the contracting parties. Submitting the report for inspection to parties who have a direct interest is permitted.

© 2009 TNO

Executive summary

Subsurface storage of captured CO₂ in depleted oil and gas reservoirs, saline aquifers, or unmineable coalbeds is currently seen as one of the most feasible ways of reducing greenhouse gas emissions. Key to evaluating this concept and to storage site selection is the assessment of system integrity, with focus on the potential for CO₂ leakage. Typically, depleted gas and especially oil reservoirs are perforated by large numbers of (abandoned) production/exploration wells. Many of these wells also penetrate deep saline aquifers that might be used for geological storage of CO₂. Although most of these wells are sealed and plugged with cement at abandonment, the well system may create potential conduits for CO₂ leakage. Potential migration of CO₂ from subsurface reservoirs along wells is generally recognized as the major hazard associated with long-term storage of CO₂ in geological formations or CO₂-enhanced recovery (EOR, EGR, ECBM) operations.

With respect to the evaluation of long-term integrity of geological CO₂ storage two types of wells can be distinguished, i.e. existing wells and future wells. Future wells can be designed, drilled, completed and abandoned taking into account the preceding CO₂ storage operations, using state-of-the-art materials and techniques to adequately deal with sour gas (mainly CO₂ or H₂S) occurrences. In contrast, most existing wells, comprising operational wells and abandoned wells, were not designed, drilled, completed and/or abandoned taking into account future CO₂ storage purposes. Operational wells generally are accessible and can be adapted to fit injection or abandonment of corrosive fluids. The main issue is with previously abandoned wells that are no longer accessible and therefore cannot be improved when needed, without huge costs. This is illustrated by several case studies, clearly demonstrating the implications of previously abandoned wells penetrating prospective CO₂ storage reservoirs as well as crucial aspects that are typically associated with these wells.

This report aims to describe current and historical abandonment practices. To this purpose first the basal plugging and abandonment techniques are briefly described. The risk of leakage through abandoned wells primarily depends on the regulations toward drilling and abandonment enforced at the time of plugging, of the diligence expressed by the operator during the plugging, and of the materials used in the plugging operation.

Subsequently, a synopsis of the adverse effects of aqueous CO₂ on typical well materials is presented, including chemical degradation of well cement and steel as well as mechanical effects that may be associated with either operational activities or degradation. Results from multiple experimental studies on cement degradation are not univocal and not in full agreement with observed phenomena from field samples. A worst case approach would be the extrapolation of laboratory results obtained at quite severe (temperature) conditions, extrapolating to CO₂-brine penetration of 12.4 m into the cement over 10,000 years. Taking into account the general results from laboratory studies, rather than this end member value, up to a few meters of cement may be affected over such time span. In the light of minimum plug length requirements, the mechanical integrity of the cement plug and the quality of its placement might be of more significance than the chemical degradation of properly placed abandonment plugs. The presence or development of fractures or annular pathways in the cement or along interfaces, between cement and casing or cement and caprock, strongly affects the permeability of the cement. These will play an important role in leakage mechanisms, potentially significantly enhancing cement degradation.

Furthermore, an overview has been generated of regulations and guidelines governing well abandonment for a selection of countries and states involved in geological storage of CO₂. Although these mainly comprise current regulations an effort was made to identify major changes in abandonment requirements. A general distinction can be observed between European and non-European countries. While in Europe the length of the cement plug is between 50 to 100 meter, in evaluated non-European regulations the length of the plug is between 30 and 60 meter. An exception is formed by the United Kingdom where approximately 30 meter (100 ft) is required. When mechanical plugs are used, additional cementing is often required of various lengths. Abandonment practices historically gradually developed to the present high standards. This implies that especially older wells may present problems, and should hence be carefully evaluated when considering their use in CO₂ storage. The evaluated regulations primarily comprise prescriptive requirements for plugging and abandonment of oil and gas wells. It should be noted that also complementary regulations on e.g. labour conditions and environmental impact can significantly influence the effective management of well abandonment.

Several risk assessment methodologies are described that can be employed to evaluate the wellbore system. In general a distinction can be made between qualitative and quantitative methods. In principle, qualitative approaches are used in the first stages of risk identification, providing means to comprehensively evaluate the system with respect to potential risks. In general a qualitative assessment will precede quantitative evaluations. Quantitative methodologies can be subdivided in probabilistic and deterministic approaches, where operations involving numerous wells benefit the most from using probabilistic risk assessment methodologies. Quantitative methods employed on storage reservoirs comprising few wells can consist of deterministic approaches.

Finally, recommendations are presented both on best practice of well abandonment and on managing previously abandoned wells regarding long-term geological storage of CO₂. As a result of uncertainties, proposed abandonment methodologies for present and future decommissioning of CO₂ wells are relatively rigid to ensure safe and efficient storage of CO₂. A procedure for permanent abandonment of CO₂ wells is described, recommending the use of specialized cement and casing materials. However, newly developed materials, techniques and methodologies can only be applied to future wells and existing, operational wells. In contrast, previously abandoned wells cannot easily be re-abandoned and will form the biggest challenge regarding long-term containment of CO₂. The most critical concerns regarding previously abandoned wells arise from the fact that the performed abandonment measures at the time did not take into account the potential application of the reservoir for CO₂ storage purposes. As a consequence, the majority of abandoned wells was not completed and plugged using design and materials compliant with storage of corrosive fluids. Furthermore, the time of decommissioning versus historical developments of applying abandonment regulations highly determine the quality and suitability of the abandonment with respect to second-life applications of assets.

When considering CO₂ storage the current state of the wells involved needs to be confidently assessed. For inaccessible wells this requires comprehensive risk assessment and monitoring efforts. In worst-case scenarios of leakage through abandoned wells, there is a limited amount of options that could be pursued. Wells could be re-entered to be remediated. Alternatively, several measures can be employed to reduce the reservoir pressure in order to both reduce the pressure gradient that drives migration and reverse potential opening of cracks or annuli. Obviously it would be beneficial if costly remediation operation could be prevented. A starting point for this is

a comprehensive assessment of the wells involved. Furthermore, it would be recommendable to assess potential future applications of depleted reservoirs prior to abandonment, so that the abandonment can be tailored to second-life applications.

Contents

	Executive summary.....	3
1	Introduction.....	9
2	Well plugging and abandonment techniques.....	11
2.1	Preliminary activities	11
2.2	Plugging	11
2.3	Cement plug evaluation	16
2.4	Abandonment practices.....	17
3	Case studies	19
3.1	Proposed CO ₂ storage in the De Lier field (The Netherlands).....	19
3.2	Well evaluation at Gulf Coast and SACROC (Texas, USA)	25
3.3	The Alberta Basin (Alberta, Canada).....	31
4	Impact of CO₂ on wellbore integrity	36
4.1	Potential CO ₂ leakage mechanisms.....	36
4.2	Chemical degradation of wellbore cement.....	37
4.3	Corrosion of casing steel.....	43
4.4	Mechanical deformation of wellbore cement.....	46
4.5	Interaction of processes.....	48
5	Well abandonment regulations.....	50
5.1	Introduction.....	50
5.2	Denmark.....	51
5.3	France	53
5.4	Germany.....	54
5.5	Norway.....	54
5.6	The Netherlands	56
5.7	United Kingdom	59
5.8	Australia.....	60
5.9	Alberta, Canada.....	61
5.10	China.....	63
5.11	Japan	64
5.12	United States of America	64
5.13	International Conventions	68
6	Risk management methodologies	70
6.1	Risk assessment	70
6.2	Risk assessment methodologies	70
6.3	Assessment of wellbore integrity.....	71
7	Recommended best practice.....	94
7.1	Existing wells and future wells	94
7.2	State-of-the-art well abandonment for corrosive fluids	94
7.3	Managing previously abandoned wells	96
8	Conclusions.....	99
8.1	Well abandonment techniques and practices	99
8.2	Well material degradation.....	99
8.3	Well abandonment regulations.....	100
8.4	Risk management methodologies	101
8.5	Recommended best practice.....	101
	Acknowledgements.....	103
	References.....	104

1 Introduction

Subsurface storage of captured CO₂ in depleted oil and gas reservoirs, saline aquifers, or unmineable coalbeds is currently seen as one of the most feasible ways of reducing greenhouse gas emissions (e.g. Bachu, 2000; Wawersik et al., 2001; IPCC, 2005). Key to evaluating this concept and to storage site selection is the assessment of system integrity, with focus on the potential for CO₂ leakage. Possible leakage paths include faults and fractures present in the caprock (Pruess, 2005; IPCC, 2005). However, potential migration of CO₂ from subsurface reservoirs along wells is generally recognized as the major hazard associated with long-term storage of CO₂ in geological formations or CO₂-enhanced recovery (EOR, EGR, ECBM) operations (e.g. Gasda et al., 2004; Pruess, 2005; IPCC, 2005; Carey et al., 2007).

With respect to leakage risk evaluation regarding long-term geological storage of CO₂, a distinction has to be made between existing wells and future wells (Watson and Bachu, 2007). Existing wells involve all wells that were drilled prior to CO₂ storage operations, generally consisting of shallow groundwater wells and deep wells for hydrocarbon production. Future wells comprise wells directly related to the CO₂ storage operations, such as CO₂ injection or monitoring wells, and wells penetrating or transecting a CO₂ storage reservoir aiming at other structures or deeper reservoirs e.g. for production of hydrocarbons or geothermal energy.

Typically, depleted gas and especially oil reservoirs are perforated by large numbers of (abandoned) production/exploration wells (Figure 1.1). Many of these wells also penetrate deep saline aquifers that might be used for geological storage of CO₂. Although most of these wells are sealed and plugged with cement at abandonment, the well system may create potential conduits for CO₂ leakage.

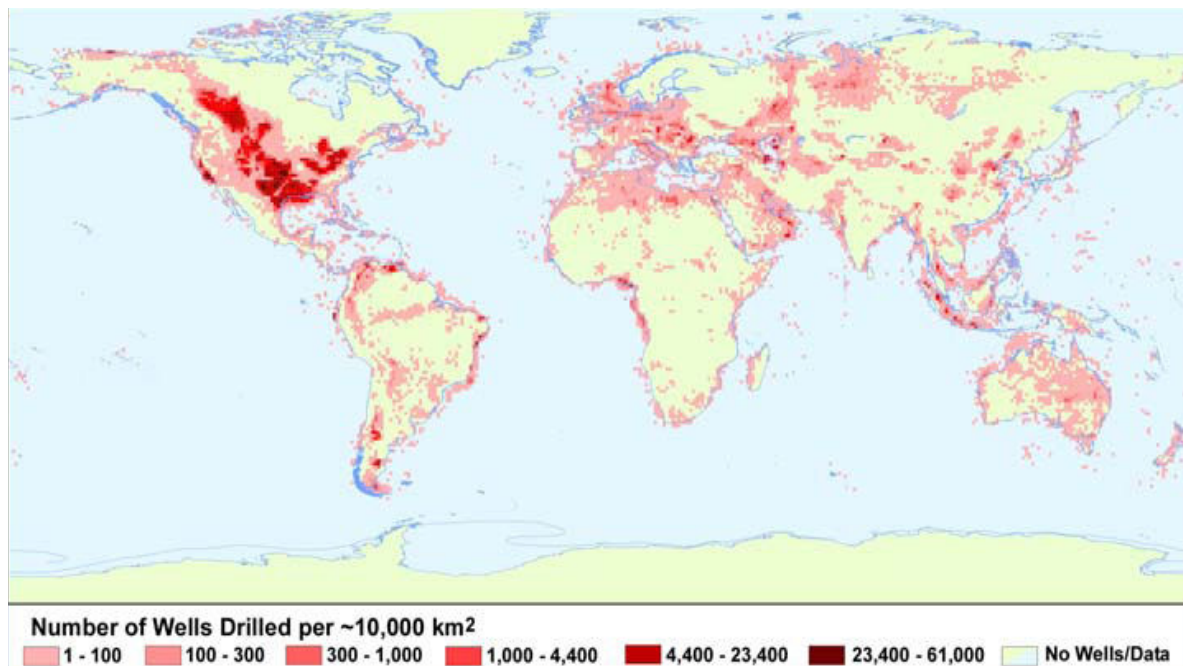

Figure 1.1 Well density reflecting locations of hydrocarbon-bearing regions. After: IPCC, 2005.

Future wells can be designed, drilled, completed and abandoned taking into account any previous CO₂ storage operations. Suitable skills and technology are readily available to effectively seal and isolate the CO₂ storage reservoir, using practices that have been developed and employed over decades in oil and gas industry to adequately deal with sour gas (mainly CO₂ or H₂S) occurrences as well as newly developed advanced techniques and state-of-the-art materials. In contrast, existing wells were designed prior to CO₂ storage, not taking into account the presence of corrosive fluids in the storage reservoir. Therefore their configurations may not agree with such purpose. If still operational, existing wells can usually be adapted to fit injection or abandonment of corrosive fluids. Although costly, such operations can be performed using suitable workover materials and techniques that are currently available in the petroleum industry. Consequently, the main leakage risk is associated with previously abandoned wells that may be no longer accessible and therefore cannot be easily improved when needed.

This report focuses on potential hazards to geological storage of CO₂ related to previously abandoned deep oil and gas wells. As many prospective CO₂ storage projects will be situated in mature sedimentary basins, these operations need to accommodate previously drilled and abandoned wells. The current study aims to provide a high order evaluation of abandoned wells and their suitability to CO₂ storage operations. To this purpose a brief explanation of the major well plugging and abandonment techniques is described in Chapter 2. Several case studies are described in Chapter 3, illustrating some typical aspects associated with abandoned wells in the context of geological storage of CO₂. In Chapter 4, subsequently, an overview of the current state of knowledge on potential degradation mechanisms of typical well materials (i.e. cement and steel) under influence of aqueous CO₂ is presented. Furthermore, in Chapter 5 a geographical overview of numerous well abandonment regulations is provided, reflecting significant differences in regulatory demands around the world. Moreover, both abandonment regulations and practices historically gradually developed to the present high standards. As a consequence, especially older wells are considered to be a potential threat to long-term storage integrity. In Chapter 6 various risk assessment methodologies are described that are tailored to well integrity evaluation for geological CO₂ storage. An overview of potential corrective measures and monitoring strategies is introduced in Chapter 7 on recommended practice. Conclusions are presented in Chapter 8.

2 Well plugging and abandonment techniques

The purpose of permanent well abandonment is to isolate permeable and hydrocarbon bearing formation to the purpose of e.g. protecting underground resources, preventing potential contamination of potable water sources and preclusion of surface leakage. Abandonment aims at restoring the natural integrity of the formation that was penetrated by the wellbore. Abandonment procedures were developed in the oil and gas industry where several techniques were designed to prevent interzonal communication and fluid migration. If a well is not properly abandoned, it may provide pathways for brines, hydrocarbons or other fluids to migrate up the well and into shallow drinking water aquifers or to surface.

The configuration of an abandoned well commonly comprises a surface casing often extending to depths below the lowermost drinking water aquifer, and a (set of) production string(s) running to the target formation. The annuli between casing and formation, and between different casing strings in general is cemented at least to an extent. Abandonment plugs consist of tailored cement types that may be supported by mechanical plugs.

In order to effectively seal a well, a stepwise procedure for plugging and abandoning wells was described by Fields and Martin (1997), addressing the removal of equipment and tools, cleaning the wellbore, plugging and testing.

2.1 Preliminary activities

2.1.1 *Removing downhole equipment*

The first step when starting a well abandonment operation is removing existing tools. This can be done using an existing drilling or conventional workover rig with the capacity to pull out of hole all downhole equipment previously used by the operator, such as production tubing, downhole pumps and packers. If tool removal is not possible due to stuck or lost equipment, well abandonment strategies have to be revised and approved by concerned authorities.

2.1.2 *Wellbore cleanout*

After the removal operation, the wellbore needs to be cleaned from fill, scale and other debris. To this purpose the wellbore is flushed by a circulation fluid with sufficient density to control pressure and with the physical properties that enable the removal of debris. Dependent on the specific conditions additional tools or additives may be required to successfully clean the hole.

2.2 Plugging

The principal technique applied to prevent cross flow between permeable formations is plugging of the well, creating an impermeable barrier between two zones. Well plugs are being used for several different operations in oil and gas industry, such as lost circulation control, formation testing, directional/sidetrack drilling, zonal isolation and well abandonment (Smith, 1993). The scope of this study is restricted to the latter two

applications. Well plugs can be either cement or mechanical plugs. Specifications of well plugs and abandonment are prescribed by regulatory authorities.

In the oil and gas industry the most common material used for plugging wells is Portland cement, which is placed in the well as slurry that hardens under influence of the in-situ temperature and pressure. A cement plug consists of a volume of cement that fills a certain length of casing or open hole to prevent vertical migration of fluids. Cement satisfies the essential criteria of an adequate plug; it is durable, low-permeable and relatively inexpensive. Furthermore, it is easy to pump in place, has a reasonable setting time and is capable of tight bonding to the formation and well casing surface preventing fluid flow along these interfaces (Calvert and Smith, 1994). In some regions, such as onshore North America, cast iron bridge plugs are as common as cement plugs.

In 1953 the American Petroleum Institute (API) defined standards on the grade and quality of different types of cement to be used in oil and gas industry (Table 2.1). API specifies that an adequate cement plug should have a compressive strength of at least 1,000 psi and a maximum liquid permeability of 0.1 mD. The different classes of API cement are based on the downhole temperature at the depths where the cement is to be placed. Cement slurries are designed to meet API definitions and recommended practices, as well as to satisfy its specific performance criteria. To this purpose additives (e.g. sand, bentonite or dispersants) may be added to the Portland cement to enhance specific properties. Dispersants reduce the water/cement ratio, providing higher strengths and lower permeability. Accelerators may also be added to the cement to increase the early strength of the plug (Calvert and Smith, 1994). However, in many parts of the world, API well cement is difficult or impossible to obtain and construction cements are applied (Rogers et al., 2006).

Table 2.1 API Classification for oil well cements¹

Class A	Intended for use from surface to 6,000 feet (1830 m) depth ² when special properties are not required. Available only in ordinary type (similar to ASTM C 150, Type I) ³
Class B	Intended for use from surface to 6,000 feet (1830 m) depth, when conditions require moderate to high sulfate-resistance. Available in both moderate (similar to ASTM C 150, Type II) and high sulfate-resistant types.
Class C	Intended for use from surface to 6,000 feet (1830 m) depth, when conditions require high early strength. Available in ordinary and moderate (similar to ASTM C 150, Type III) and high sulfate-resistant types.
Class D	Intended for use from 6,000 feet to 10,000 feet (1830 m to 3050 m) depth, under conditions of moderately high temperatures and pressures. Available in both moderate and high sulfate-resistant types.
Class E	Intended for use from 10,000 feet to 14,000 feet (3050 m to 4270 m) depth, under conditions of high temperatures and pressures. Available in both moderate and high sulfate-resistant types.
Class F	Intended for use from 10,000 feet to 16,000 feet (3050 m to 4880 m) depth, under conditions of extremely high temperatures and pressures. Available in both moderate and high sulfate-resistant types.
Class G&H	Intended for use as a basic well cement from surface to 8,000 feet (2440 m) depth as manufactured or can be used with accelerators and retarders to cover a wide range of well depths and temperatures. No additions other than calcium sulfate or water or both, shall be interground or blended with the clinker during manufacture of Class G or H well cement. Available in moderate and high sulfate-resistant types.

¹ Reproduced courtesy of the American Petroleum Institute from API Spec. 10 "API Specification for Materials and Testing for Well Cements."

² Depth limits are based on the conditions imposed by the casing-cement specification tests (Schedules 1, 4, 5, 6, 8, 9) and should be considered as approximate values.

³ ASTM (American Society for Testing and Materials) C 150: Standard Specification for Portland Cement.

In general a minimum of three cement plugs are placed during abandonment operations. These include a cement squeeze at the level of the perforations, a plug that is usually located near the middle of the wellbore, and a surface plug installed at shallow levels (Fields and Martin, 1997). Additional plugs may be placed depending on the specific conditions. However, proper plugging of a well is not always successful at first attempt. A long standing standard was that an average successful plug at the bottom of a wellbore would require 2.4 attempts (Crawshaw and Frigaard, 1999).

In the current operational practice, there are three major methods for well plug placements, i.e. the balanced plug method, the dump bailer method and the two-plug method. API recommends the abandonment to be chosen after an analysis of the well for probable risks and potential problems with respect to the different abandonment techniques (Englehardt et al., 2001). However, in reality ideal practices are not always successfully achieved.

2.2.1 *Balanced plug method*

The balanced plug or displacement method is the most common placement method. This technique involves the drillpipe or tubing to be placed at the planned plug base depth. Subsequently the cement slurry is placed on top of a mechanical device (such as a bridge plug) or viscous fluid or mud serving as the plug base. The slurry is pumped through the tubing until the level of the cement in the annulus is equal to that inside the casing (Figure 2.1). To prevent mud contamination, a spacer fluid is pumped ahead and behind the slurry. Once the plug is balanced, the tubing is pulled out of the slurry (Nelson and Guillot, 2006).

This method is one of the simplest techniques used in oil industry and is often used for placement of the middle plug of a well (Fields and Martin, 1997). The main problem is that of potential cement contamination. This can be minimized by using appropriate plug base material, such that downward migration of the cement plug is prevented (Nelson and Guillot, 2006).

2.2.2 *Cement squeeze method*

The presence and good quality of the primary cement sheath at the plugging level is essential for realizing zonal isolation. If cement behind the casing is lacking or inadequate, several methods can be applied to remediate the cement sheath and achieve isolation. API recommends using one of the three following cement squeeze methods (Englehardt et al., 2001): Squeeze cementing, block cementing or circulating cement.

Squeeze cementing involves the process of forcing by pressure a cement slurry into a specified location in a well through perforations in the casing or liner. Once the slurry encounters a permeable formation, the cement solids are filtered out of the slurry as the liquid phase is forced into the formation matrix in the form of cement filtrate. Squeeze cementing is a remedial cementing technique used to repair flaws in primary cement or damage incurred by corrosive fluids. A properly designed squeeze-cement operation will fill the relevant holes and voids with cement filter cake that will cure to form an impermeable barrier.

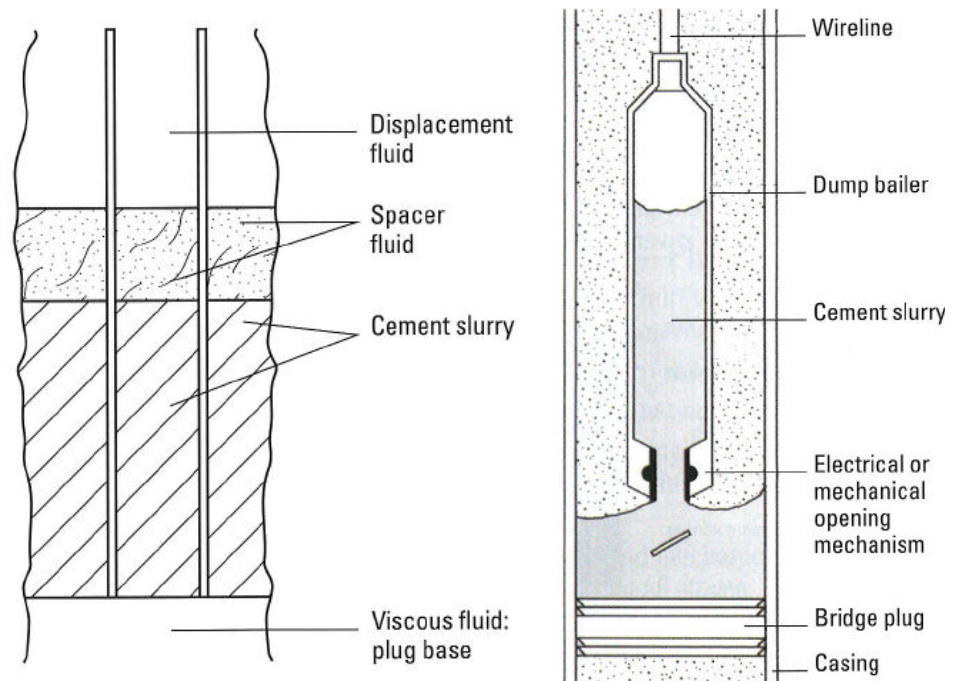

Figure 2.1 Balanced plug method (left) and Dump bailer method (right). From: Nelson and Guillot (2006).

Block cementing is used to isolate a permeable zone. To this purpose the sections above and below the target formation are perforated and squeezed (Nelson and Guillot, 2006). This procedure is often applied before starting production of permeable zones.

A circulating squeeze involves circulating cement between two sets of perforations, isolated in the string by a packer or cement retainer. The operations consist of an initial circulation with water or acid as receding fluid, a subsequent circulation of the interval with a cleaning wash fluid, and pumping and displacing of the cement slurry. This method is a low pressure squeeze. Except for some increase in hydrostatic pressure resulting from the increasing cement column in the annulus, no pressure buildup is associated with this type of cement squeeze. The exact amount of required cement is unknown, leading to the use of excess cement. This holds the risk that cement slurry enters the casing above the packer or retainer. If this cement would cure, the tubing may become stuck in the hole (Nelson and Guillot, 2006).

Alternatively, at abandonment an operator could cut and pull the casing and isolate the remaining stub using the displacement method.

2.2.3 *Dump Bailer Method*

A dump bailer is a tool that contains a measured quantity of cement, lowered into the wellbore on a wireline (Fields and Martin, 1997; Figure 2.1). Applying this method, the cement is placed on top of permanent bridge plug placed below the desired plug interval. The bailer is opened by touching the bridge plug or by electronic activation and the cement is dumped on the plug by raising the bailer. As the slurry is stationary during its descent, considerations are required regarding special slurry-design (Nelson and Guillot, 2006).

The dump bailer method is usually used for setting plugs at shallow depths, but can also be used at greater depths by using properly retarded cement systems. The advantages of this method are that the depth of the cement plug is easily controlled, and it is relatively inexpensive. A disadvantage is that the available quantity of cement is limited to the volume of the dump bailer. However, this can be solved by performing different runs. Furthermore, as the cement slurry is stationary in the bailer during its descent, special slurry design considerations are required to prevent slurry gelation or instability (Nelson, 1990).

2.2.4 Two-plug method

The name of the two-plug method is derived from the fact that the cement plug is placed with two (top and bottom) wiper or cementing plugs (Figure 2.2). This method is described by Nelson and Guillot (2006) and involves a special tool setting a cement plug in a well at a calculated depth, with a maximum of accuracy and a minimum of cement contamination. The tool comprises a bottom hole landing collar installed at the lower end of the drill pipe, an aluminium tail pipe, a bottom wiper plug (carrying a dart), and a top wiper plug. The application of cementing plugs enables the effective separation of the cement slurry from other fluids, reducing contamination and maintaining predictable slurry performance. The bottom plug is launched ahead of the cement slurry to clean the drill pipe and to minimize contamination by fluids inside the casing prior to cementing. A diaphragm in the plug body ruptures by increased pump pressure to allow the cement slurry to pass through after the plug reaches the landing collar. The top plug is pumped behind the cement slurry to isolate the cement from the displacement fluid. This plug has a solid body that provides positive indication of contact with the landing collar and bottom plug through an increase in pump pressure. The top plug then prevents cement from flowing up into the tubing string, meanwhile permitting reverse circulation. The drill pipe is pulled up until the lower end of the tail pipe reaches the calculated depth for the top of the cement plug.

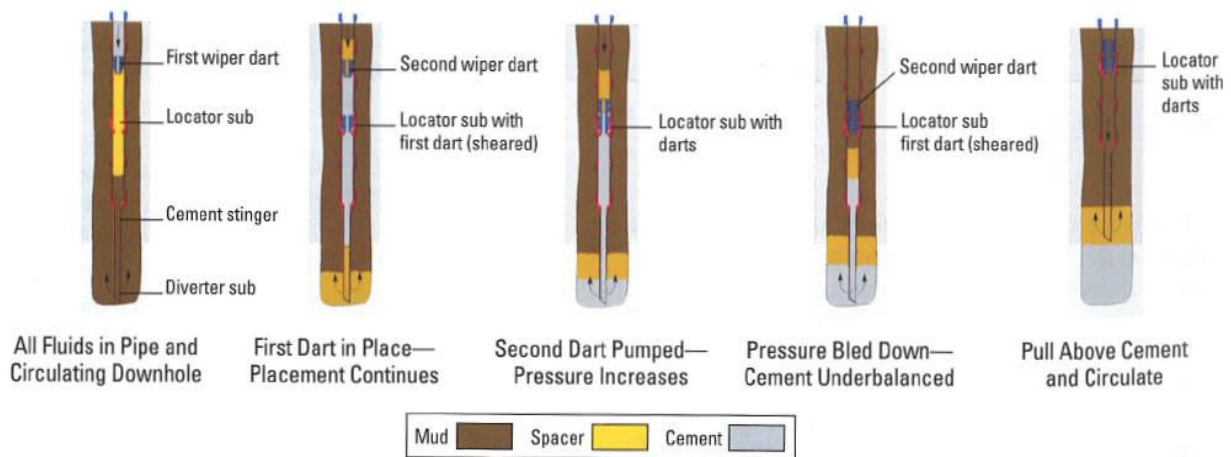

Figure 2.2 Two-plug method. From: Nelson and Guillot (2006)

2.3 Cement plug evaluation

After the well is plugged, testing is required to ensure that the plug is placed at the proper level and provides zonal isolation. The plug can be verified by tagging its top, pump pressure testing or swab testing.

Tagging the top of cement (TOC) can be done through the employment of a drill pipe, wire line, work string or tubing. The procedure, recommended by API, is a very straightforward operation with the benefit that no additional pressure needs to be put on the wellbore. It enables exact determination of the top of the plug. Tagging the plug with open-ended pipe can also be applied for testing the cement plug's integrity. However, disadvantages of this method comprise the concentration of the load on the area where the pipe hits the cement, the required incorporation of corrections for buoyancy and friction when using the pipe weight, and potential weight insufficiency for shallow plugs (Fields and Martin, 1997). Furthermore, a plug may be tested to be rigid at the top, while it shows less strength further down, leading to potential fluid migration over time (Smith, 1990).

Alternatively, pressure test can be executed using pump pressure. In this case the pressure is exerted uniformly on the plug and no corrections are required. The application of pump pressure provides more accurate data on the pressure, which could also be monitored over time (Fields and Martin, 1997). However, the associated changes in pressure itself could initiate casing integrity problems if the well cannot sustain the enforced pressure changes. Furthermore, it could lead to loss of wellbore control if conditions are not static (Englehardt et al., 2001).

Another pressure testing method is swab testing or swabbing. This technique involves running of a swabbing tool that reduces the pressure in the wellbore above the plug to levels below the pressure gradient from the isolated reservoir below the plug. Subsequently fluid levels and pressure are monitored to ensure adequate isolation. Swabbing is more time-consuming relative to the other methods.

2.3.1 *Plugging effectiveness*

Nicot (2008) describes the risk of leakage through abandoned wells as a function of regulations toward drilling and abandonment enforced at the time of plugging, of the diligence expressed by the operator during the plugging, and of the materials used in the plugging operation. Inadequate well design, well construction or plugging/abandonment performance may lead to poor isolation. Primary causes of failure are connected to mud contamination as a result of poor mud removal (most common), unstable cement slurries, insufficient slurry volume, and poor job execution (Nicot, 2008).

These problems may be more abundant among older wells as plugging improvements were developed over time. First, the two-plug method, limiting potential mud contamination, was patented by Halliburton in 1922. Around 1930 the use of centralizers was introduced, enabling more uniform distribution of cement in wells through tubing (Smith, 1976; in: Nicot, 2008). Furthermore, before the invention and widespread use of a caliper survey instrument in the 1940s the exact quantity of cement needed for a thorough job was not available. In addition, before testing of the plug became a requirement, the plug location was not checked but assumed to be located as planned (Nicot, 2008).

Also advances of cementing materials over time enhanced plugging effectiveness, as reported in Nicot (2008): Before 1928, only a single type of cement was available for plugging. In 1940, cement manufacturers provided two types of Portland cement and three additives. After the late 1940s, the number of commercially available additives progressively increased. Since then, the American Petroleum Institute (API) has devised several classes of cement for different well conditions (pressure, temperature, and chemical conditions and, in particular, resistance to sulfate attack). National standards on cements for use in wells in the USA were published by API in 1953, enabling operators to tackle more difficult cementing jobs and ensure better cement placement. Due to the inadequate quality of cements used in advance of the implementation of the API standards, wells plugged with cement prior to 1952 are often not considered to have effective cement plugs (Ide et al., 2006). Although the main composition resembled that of today's plugging cement, important additives like bentonite, dispersants and accelerators were not incorporated, leading to difficulty in constraining cement hardening, and consequently contamination of cement with drilling muds.

It should be noted that the implementation alone of regulations and guidelines does not necessarily imply that these were followed in full, since regulations have not always been strictly enforced over time in different areas in the world.

2.4 Abandonment practices

In order to develop a comprehensive overview of applied well abandonment techniques, common practice of well drilling, plugging and abandonment needs to be evaluated in different regions throughout the world. To this purpose, a questionnaire was developed and distributed amongst experts active in operating and service companies, consultancies, regulator bodies and research institutes involved in oil well drilling and abandonment activities worldwide. This section comprises a concise description of the results of the well abandonment survey. However, the collected amount of data proved to be insufficient to extrapolate and investigate regional differences.

2.4.1 *Overview of well characteristics from representative fields or basins*

Respondents provided information on well abandonment practices in Europe (onshore and North Sea), North America and Australia. Representative fields or basins mostly show well densities ranging between 1 to 100 wells/km², while some records from North Sea gas fields indicate less than one well per square kilometre. Well densities in some high viscous oil fields exceed 100 wells/km². Most of the wells in the representative fields are dated post-1960 and drilled to depths over 5,000 ft. A significant number of fields holds wells extending over 10,000 ft depth. This is obviously reflected by resulting pressures, showing a roughly even distribution over pressures from 1,000 psi to values higher than 5,000 psi.

2.4.2 *Data availability*

The majority of respondents indicated that for almost all wells (90-100%) data is available on well location (coordinates), present status of the well (i.e. operating, abandoned, etc.) and the well configuration. The latter comprises information on cased depths, top of cement, plug lengths, but also on the materials applied (i.e. type of cement, steel grade). A single respondent indicated that data is available only for 30-70% of the wells.

2.4.3 *Drilling and completion*

Various steel grades are used for casing, such as J55, K55, L80, N80, C95, P110 and Q125. In general the application follows guidelines on H₂S content, temperature and pressure conditions. In corrosive environments, it is common practice to use Cr-13 type of steel (e.g. L80Cr-13), and/or corrosion inhibitor fluids. All respondents indicated that, prior to placement of annular cement, the borehole is prepared or cleaned. Subsequently, a primary cement sheath is placed over some length of the well, generally ranging from 30 to 90% of the wellbore length (one instance states 90-100% of the well being cemented). Approximately half of the respondents indicate that during drilling and completion no leakage occurs, while others indicate 10-30% of wells showing initial leakage (i.e. sustained casing pressure, gas migration outside the casing), as a result of casing corrosion or wear, poor cement coverage, improper slurry design or overpressurization of the wellbore.

2.4.4 *Abandonment*

All respondents reported to perform well abandonment according to regional or national regulatory frameworks or, in absence of these, according to international guidelines of OSPAR or the London Convention. Variations in regulations are reflected in the differences between plugging requirements. While some regulations demand records (e.g. pressure tests and/or cement bond log) on the status or integrity of the wells prior to abandonment, others have no specifications on this topic. The majority of regulatory frameworks stipulates plugs to be emplaced using the balanced plug method, whereas the dump bailer method and a choice between the balanced plug and the two-plug methods are noted on a single occasion. The prescribed minimum number of plugs ranges from 1 to 3, with minimum lengths between 8 to 100 m. Regulated plug testing methods generally involve either a weight test or pressure test, possibly in combination with a tag test. Rarely specific requirements are in place for corrosive environments, but if so these comprise the application of Cr-13 steel or inhibiting fluids in the wellbore.

Between operators there is disparity regarding their approach to well abandonment with respect to potential future applications of fields and wells. Although the majority of operators does not take into account second life applications, some started recently to evaluate the field's value for future purposes prior to abandonment. In general, company practices closely reflects governing regulations, although operators may apply more stringent measures to secure well integrity (e.g. longer plug lengths) especially in corrosive environments (e.g. applying corrosion resistant measures and materials). This observation confirms the appropriateness of evaluating regulatory requirements as an adequate proxy for well abandonment practice.

While most respondents indicated that leakage is seldom observed in abandoned wells, some incidences (amounting between 0 to 30% of the abandoned wells) of sustained casing pressure or gas migration outside of the casing is reported, probably due to e.g. poor cement coverage, improper abandonment, overpressurization of the well, or micro-channelling in the cement.

3 Case studies

Several case studies are presented illustrating specific aspects of wellbore integrity. The De Lier case describes the evaluation of an onshore depleted gas reservoir in the Netherlands for proposed CO₂ storage. This feasibility study demonstrated several concerns that may rise when proposing second life applications for depleted hydrocarbon fields. The following section reflects some issues reflected by case studies on Texas, USA. It discusses both the effect of regulatory developments on well leakage probability as well as insights on well material degradation from samples retrieved at wells that were exposed to CO₂ for a minimum of 30 years. Finally, extensive well leakage evaluations in Alberta are described, focusing on either oil and gas recovery wells and CO₂ and acid gas injection wells.

3.1 Proposed CO₂ storage in the De Lier field (The Netherlands)

In 2006 the ‘Nederlandse Aardolie Maatschappij’ (Dutch Oil Company; NAM) considered the possibility of injecting and storing CO₂ in the depleted gas reservoir of the De Lier field, located a few kilometres to the north of the port of Rotterdam in the Netherlands. The field is one of the older NAM assets in the onshore Rijswijk Concession, the production of which started in 1958 and ceased in 1992. The De Lier field consists of several stacked reservoirs (Figure 3.1, right). The De Lier gas reservoir has a thickness of 45 m and belongs to the Holland Greensand Member with the top structure at a depth of 1350 m below the earth’s surface. At deeper levels other hydrocarbon reservoirs are present, such as the oil-bearing De Lier sand-shale member with the top at approximately 1550 m depth. A reverse fault is bounding the SW flank of the structure, and a normal fault is bounding the structure from the NE side. The top seal of the Holland Greensand reservoir comprises a 30 m-thick Middle Holland Claystone layer, which is overlain by the 70-100 m-thick Upper Holland Marl. The initial pressure in the Holland Greensand gas reservoir was 150 bar, while the pressure of the depleted reservoir was 30 bar at abandonment. The reservoir temperature is 58°C.

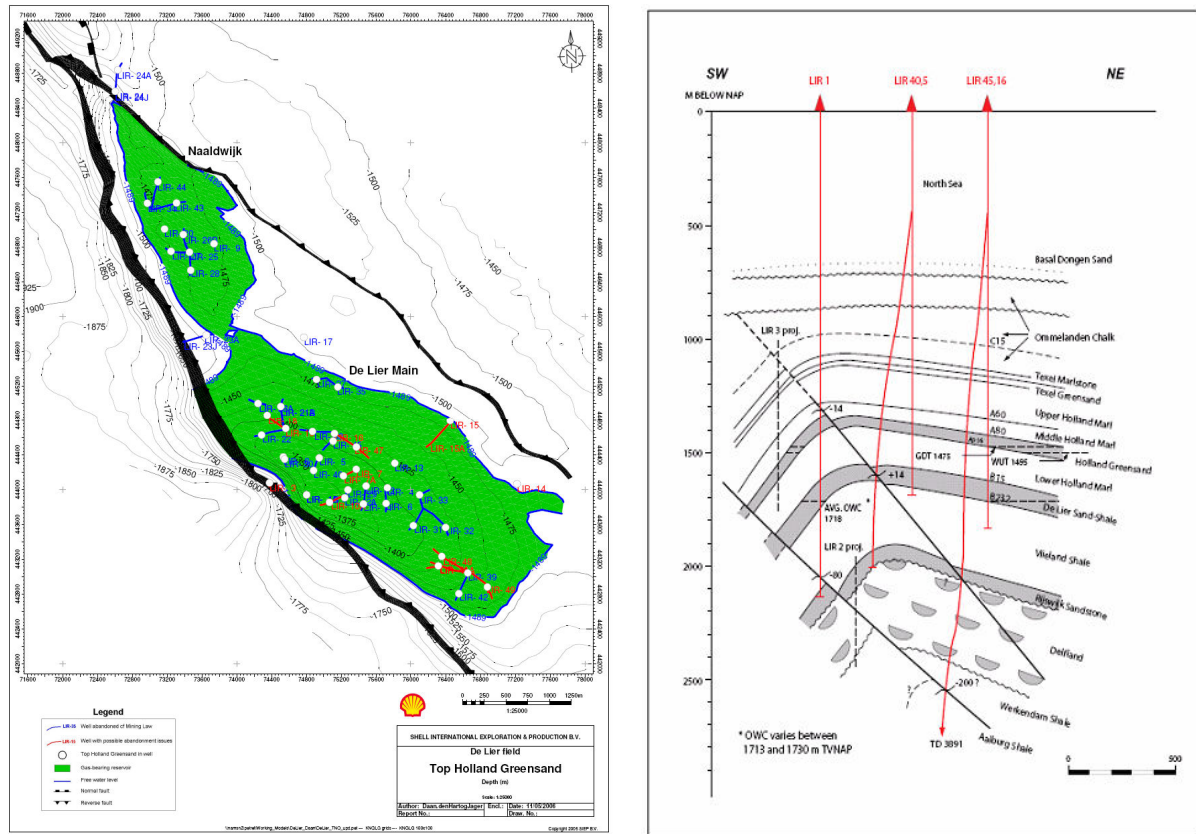

Figure 3.1 Top Holland Greensand depth map of the De Lier field (left). Cross section through the De Lier field showing stacked oil and gas reservoirs (right). Source: NAM.

One of the concerns regarding health, safety and environment for second life application of the field (such as the proposed injection and storage of CO₂ in the reservoir), was the integrity of previously abandoned wells. It should be noted that when considering geological storage of CO₂ or other second life applications, the status of the field and the involved wells are integrally re-evaluated by the operator and the regulator with respect to the projected new purpose. Other abandonment requirements will apply, governed by the containment of corrosive fluids, rather than by abandonment of depleted hydrocarbon fields. Substantial effort may be needed to adapt the current state to requirements associated with the proposed completely new situation.

3.1.1 Regulatory framework

Regulatory instruments involved in the evaluation of abandonment programmes constitute the Dutch Mining Regulations, the Dutch Mining Decree and the Working Conditions legislation. While the Mining Regulations dictate prescriptive rules on well abandonment, the Mining Decree involves goal-setting legislation on the construction, intervention and abandonment of boreholes and wells to reach an acceptable risk level to these HSE interests. Compliance to these goal-setting elements of the Mining Decree is generally demonstrated using best practices and state-of-the-art techniques. In addition, the Mining Decree is coupled to the Safety Case regime under the Working Conditions Act, requiring justification of risks to workers on a mining location or installation, in each step of its lifetime, to be acceptable. The governing regulatory framework for (re-)evaluation of abandonment programmes is described in detail in Section 5.6.

Currently, the Mining Act, Decree and Legislation have not yet been revised for geological storage of CO₂ or other second life applications. However, through the integral approach of both the goal-setting and prescriptive elements of the Mining legislation, supplemented with the Safety Case requirements of the Working Conditions legislation, regulatory instruments so far already seem reasonably comprehensive.

3.1.2 *Review of well abandonment status*

The De Lier gas reservoir is penetrated or transected by 52 wells, of which 51 are currently abandoned. In total, 49 wells were drilled in the De Lier field itself (Figure 3.1, left), while three wells from the adjacent Monster field also penetrate the Holland Greensand formation. All 49 wells in the De Lier field were plugged and abandoned, as well as two of the wells in the Monster field (one is still operating). Most of the abandoned wells transect the Holland Greensand Member to reach for reservoir stacks at deeper levels, such as the oil reservoir at the De Lier Sand-Shale level (Figure 3.1, right). Shell and NAM previously concluded that most abandonments are of recent date and meet high standards, except for three wells, which were abandoned under different standards that applied during the early sixties or late fifties (Van Luijk, 2003). Wells that are classified as being plugged and abandoned according to Dutch Mining Regulations contain cement plugs that were designed and tested according to the prescriptions. Furthermore, these wells did not show any gas bubbles or casing pressure build-up during the three months observation period after (re-)abandonment. NAM performed a preliminary review of the status of all 51 abandoned wells in the De Lier and Monster fields, resulting in a subdivision of the plugged and abandoned wells into three categories.

Categories I and II comprises wells that were successfully plugged and abandoned in compliance with prescriptions of Dutch Mining Regulations (DMR) for corrosive fluids: abandonment of 34 wells was successful at the first attempt (category I), while 6 wells required re-abandonment resulting in adequate plugging at the second attempt (category II). Its abandonment configurations comply with DMR requirements for underground storage of corrosive fluids. The prescriptions by Dutch Mining Regulations are comparable to the most rigid regulations around the world and significantly more stringent than regulations in e.g. the USA or Alberta, Canada (see Chapter 5).

Category III consists of 11 wells that were successfully plugged and abandoned according to Mining Regulations, but do not comply with requirements for the presence/injection of corrosive fluids. For the current purpose of oil and gasfield abandonment this is satisfactory, as no corrosive fluids are present at this time. It should be noted that NAM's abandonment requirements are amongst the most stringent worldwide and these wells still favourably compare with current abandonment requirements from e.g. the USA.

3.1.2.1 *Wells of categories I and II*

Upon the depletion of the gas and oil reservoirs, the wells of the De Lier field were abandoned according to Mining Regulations. In fact the abandonment measures performed on wells of categories I and II were rigid such that they even complied with prescriptions for the presence of corrosive fluids. On a first glance these wells therefore would seem adequate also for storage of CO₂. However, even if these wells were adequately abandoned upon the end of hydrocarbon production, this does not

necessarily implicate that this decommissioning is acceptable when taking into account future applications of the abandoned field or wells.

Regarding the proposed CO₂ storage in the De Lier field, a complicating factor proved to be the stacked nature of the field. While storage was proposed in the depleted Holland Greensand reservoir, many wells transected this level targeting oil-bearing strata at greater depth. These wells were abandoned to successfully isolate the oil-bearing formations at the end of production, but since the wells were not perforated at the level of the Holland Greensand, they were not plugged at that level. This aspect can be illustrated by LIR-47 well. In this well, the top of the Holland Greensand Member is located at a depth of approximately 1440 m (Figure 3.2). At abandonment this formation did not act as a reservoir, and in compliance with Dutch Mining Regulations the well therefore was not plugged at this level, leaving it cased and cemented. However, in the light of proposed storage applications this abandonment configuration would need to be adjusted. Under the worst case assumption that, given sufficient time, the injected CO₂ in combination with the connate reservoir water would be able to partially corrode the cement sheath and casing at the Holland Greensand level, CO₂ would be able to enter the well and migrate upwards until the first cement plug at a depth of 205 m. As a result CO₂ would accumulate at shallow depth (i.e. 205 m) with a single cement plug between the CO₂ and the surface, or (once again due to corrosion) migrate out of the well to flow into shallow permeable formations.

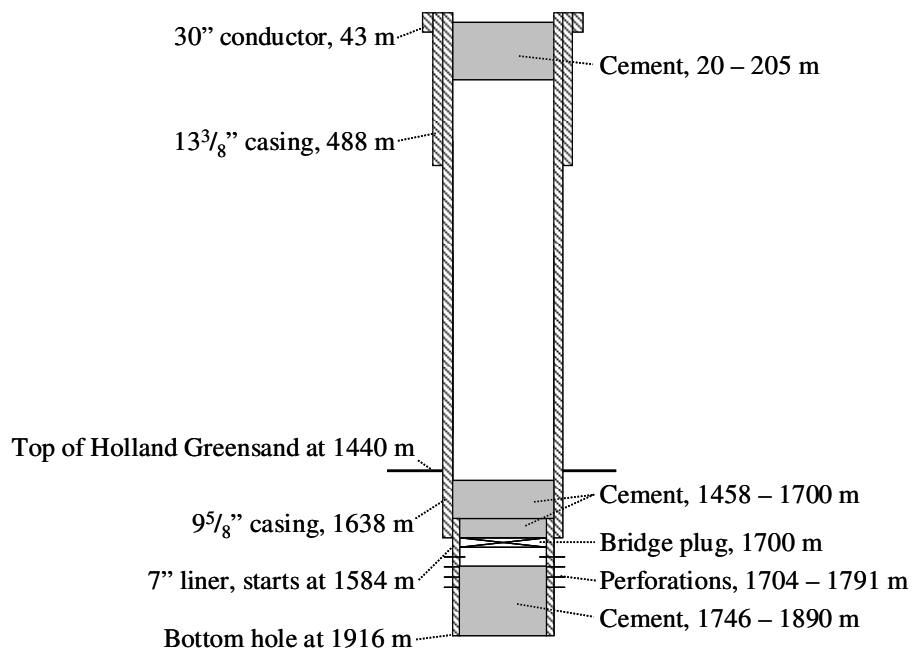

Figure 3.2 Schematic diagram of well LIR-47 after abandonment, showing the absence of an abandonment plug at the level of the caprock of the proposed CO₂ storage reservoir (Holland Greensand Member).

Similar to LIR-47, no abandonment plug is present at the top of the Holland Greensand Member (at 1390 m) in LIR-7. In case CO₂ would be stored in the reservoir, ultimately corrosion of the cement sheath and casing at this level could lead to leakage of CO₂ into the well. Subsequently, CO₂ can migrate upwards through the well until the level of the mechanical bridge plug at 693 m, where it will accumulate and potentially corrode both the casing and the bridge plug. However, unlike well LIR-47, at LIR-7, the interval of the 7-inch casing between 911-621 m is not cemented (Figure 3.3). Therefore one less

barrier is in place to contain CO₂ in the well and after the casing at these levels would have been corroded, the CO₂ reaches the uncemented well part and can migrate further upwards through the annulus. It remains unclear whether the potential pathway would extend to levels equivalent with the upper part of the cement plug at 693-599 m or to the connection to the LIR-46 sidetrack.

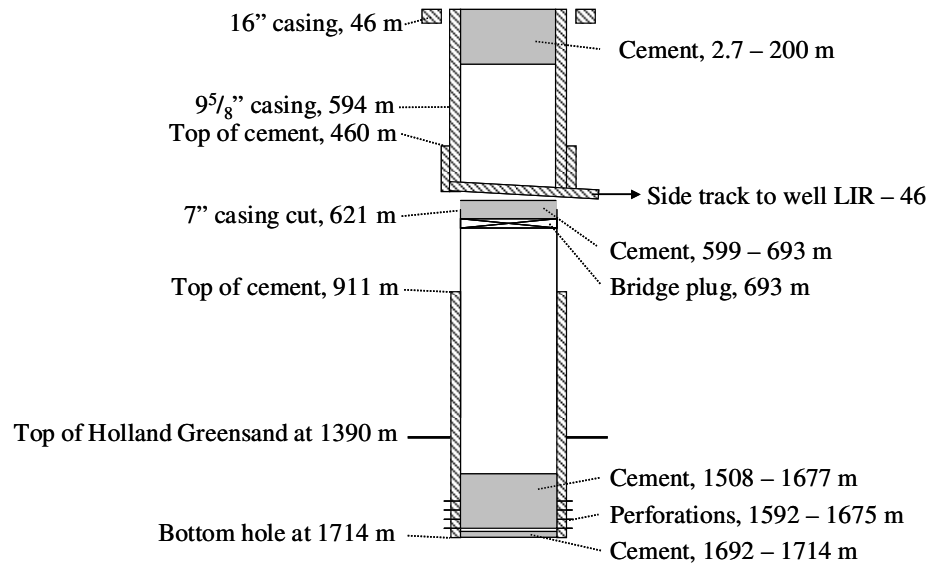

Figure 3.3 Schematic diagram of well LIR-7 after abandonment. Some uncertainty exists about the exact configuration near the side track to well LIR-46.

Taking into account the proposed storage of CO₂ in the Holland Greensand reservoir, significant adaptations of the current abandonment configuration would result from the re-evaluation of these wells by the operator and the regulator to ensure safe and effective storage.

3.1.2.2 Category III wells

The 11 wells that were successfully plugged and abandoned according to Mining Regulations, but do not comply with requirements for the presence/injection of corrosive fluids, obviously are candidates for repair requirements when CO₂ would be injected in the Holland Greensand reservoir. Different reasons obstruct their suitability and should be remediated when taking into account long-term CO₂ storage.

Two wells (LIR-10 and LIR-16) do not have a cement plug of at least 50 m on top of the mechanical bridge plug placed between the Holland Greensand and the underlying De Lier oil-bearing formation, which would be required in case of involvement of a corrosive fluid. The LIR-10 well lacks a cement plug between the Holland Greensand and the underlying De Lier oil-bearing formation. The LIR-16 well does not hold adequate isolation between the De Lier formation and the Vlieland formation, but includes a 150 m cement plug between the Holland Greensand and the De Lier formation. These issues should not pose a direct problem for the proposed CO₂ storage purpose, as the involved lacking plugs are situated at deeper levels than the proposed CO₂ storage reservoir.

After the first abandonment attempt, gas leakage from the Texel and/or Holland Greensand formations was observed from several wells. In order to reach an effective

plugging in a second attempt, silicon squeezes were applied on six wells (LIR-4, LIR-18, LIR-19, LIR-41, LIR-48 and LIR-49). Although appropriate to seal off hydrocarbons, it remains uncertain whether the silicon is resistant to CO₂ and CO₂-rich waters.

Three wells (LIR-3, LIR-14 and LIR-15) were abandoned prior to the enforcement of abandonment regulations and therefore do not have the required cement column lengths according to the current Dutch Mining Regulations. However, except for the surface plugs of LIR-14 and LIR-15 wells, showing lengths of 6 and 10 m, respectively, all abandonment plugs significantly exceeds lengths recommended by e.g. API (1993), who advise a cement plug to extend at least 50 ft (15.24 m) above and below the casing shoe.

3.1.3 *Implications*

The De Lier case of well abandonment provides an excellent example of some typical issues that could arise when considering second life applications of fields. First of all, it is obvious that the historical development of abandonment regulations plays an important role. In the De Lier field three out of 51 abandoned wells were plugged before regulation was put into force in 1967. These wells show significantly shorter cement plugs relative to current standards. However, they comply with the philosophy of the Mining regulations and Decree, meeting standards to effectively isolate the current low pressure depleted gas reservoir.

However, in the feasibility phase of proposed redevelopment of the field, the status of all wells has been re-evaluated in the context of long-term CO₂ storage in the Holland Greensand reservoir. The fact that the De Lier field consists of a stack of reservoirs leads to increased complexity. Several wells that transect the proposed CO₂ storage reservoir at the Holland Greensand level are actually aimed at deeper strata. Furthermore, the performed abandonment measures at the time did not take into account the potential application of the reservoir for CO₂ storage purposes. During the abandonment of these wells, no cement plugs were required at cap rock level of the Holland Greensand reservoir as long as no perforations were present at this level. The current abandonment status and configurations do not pose any threat to gas leakage to surface. However, if corrosive fluids would be injected and stored in the Holland Greensand reservoir, additional abandonment measures would be required to comply to the goal setting elements in the Mining Decree and Work Conditions legislation (see Chapter 5), by using best practices and state-of-the-art techniques in order to reach acceptable risk levels with respect to health, safety and environment interests.

Based on the outcome of the well evaluation, NAM decided that geological storage of CO₂ in the De Lier field was not economically feasible at the time. Costly workover operations would be required on several wells to reduce CO₂ leakage risks to acceptable levels. Some of these wells were not even accessible as a result of urban expansion. Moreover, on basis of the lessons learnt from this study NAM improved its company best practice on well abandonment. Although not required by Dutch Mining Regulations, as of 2006 NAM aims to abandon wells in a manner compatible to CO₂ storage in case the site has been earmarked for potential future CO₂ storage. NAM's adoption of this abandonment philosophy enhances the potential of their assets for future applications, and consequently its value.

3.2 Well evaluation at Gulf Coast and SACROC (Texas, USA)

Hydrocarbon production in the USA kicked off with the first well drilled in 1859 in Pennsylvania. By 1992 approximately 3.2 million boreholes were drilled for oil and gas exploration and production throughout the USA (Calvert and Smith, 1994). Of these about 600,000 were still producing in 1992, leaving 2.6 million wells dry, inactive or abandoned. Since the 1950's many of these wells have been converted into injection wells for disposal of oil field brine.

Significant numbers of the relatively shallow wells, drilled and abandoned before 1930, were not plugged with cement and are not governed by operators. These are the so-called orphan wells. However, also in recent times, such as after the 1986 oil crisis many deeper wells were left unplugged after operating companies became insolvent. Although legal responsibility is lacking, frequently these wells are monitored by state authorities. In contrast, abandoned wells are generally not monitored for leakage by state authorities, as successfully plugged wells are considered to maintain their sealing integrity (Ide et al, 2006). However Hovorka et al. (2004; 2005; in: Nicot, 2008) concluded from the evaluation of 19 penetrations in the area of review of a CO₂ injection well at the Frio experiment, that only 3 abandoned wells were plugged with cement below the lowermost drinking water zone.

Texas has a long tradition of oil production. The state still holds the largest crude oil reserves of the USA, amounting 5.1 billion barrels in 2007 (EIA, 2007). Except for the Gulf of Mexico (1.3 million barrels crude oil per day in 2006), the highest oil production rates in the USA are found in Texas. With a production of 1.088 million barrels per day Texas accounted for 21% of the total domestic production in 2006 (EIA, 2006). The first oil wells in Texas were drilled in 1866 (Ide et al., 2006). As the earliest state rules on abandonment were not enforced before 1920-1930, many wells in the state of Texas that were abandoned before these regulations were in place will have inadequate plugging configurations (Calvert and Smith, 1994).

Similar to other states, Texas holds many orphan wells, i.e. wells that were never plugged and are no longer under active company control. The costs to plug orphan wells, averaged at approximately \$ 4,500 per well, are partly funded by tax revenues on oil production. However, with approximately 135,000 orphan wells situated in Texas alone, the available funds in the order of \$ 10 million are only a few percent of the required amount (Calvert and Smith, 1994; Ide et al, 2006). Between 1965 and 2005 over 20,000 wells were plugged in Texas using the Railroad Commission's 'Well Plugging Funds' (Nicot, 2008). In general the orphan wells comprise wells abandoned prior to 1930 that were drilled to relatively shallow depths.

3.2.1 Gulf Coast – well density and data availability

The Texas Gulf Coast comprises oil and gas districts 2, 3 and 4 of the Texas Railroad Commission (Figure 3.4, right-hand side). The region is put forward as a promising target for geological storage of CO₂ by Nicot et al. (2006a). It is characterized by intensive oil and gas exploration and production, reflected in the large amount of wells drilled (about 127,000) and extremely high average well density of 2.4 wells/km² (Figure 3.5; Nicot, 2008). Especially in the northern part of the Gulf Coast, the Houston area, the well distribution is not spatially uniform as it is governed by the occurrence of piercing salt diapirs, resulting in numerous and complex traps where well densities can amount hundreds to of wells per square kilometer. In the Corpus Christi area towards

the south hydrocarbon traps are controlled by more common structures along growth faults (Nicot et al., 2006a). It should be noted that the number of penetrations per square kilometer decreases with depth. The Gulf Coast is one of the areas in Texas with a large number of deeper wells, although the majority of wells is situated at depths between 1,500-3,000 m. Only 10% of the fields in the region is deeper than 3,000 m (Nicot, 2008). Well defects leading to leakage are in general less probable for deep reservoirs, as the quality of abandonment practices improved through time along with drilling depth. Figure 3.4 represents wellbores of three onshore districts of the Texas Railroad commission only, but similar time-depth relations likely hold for other areas.

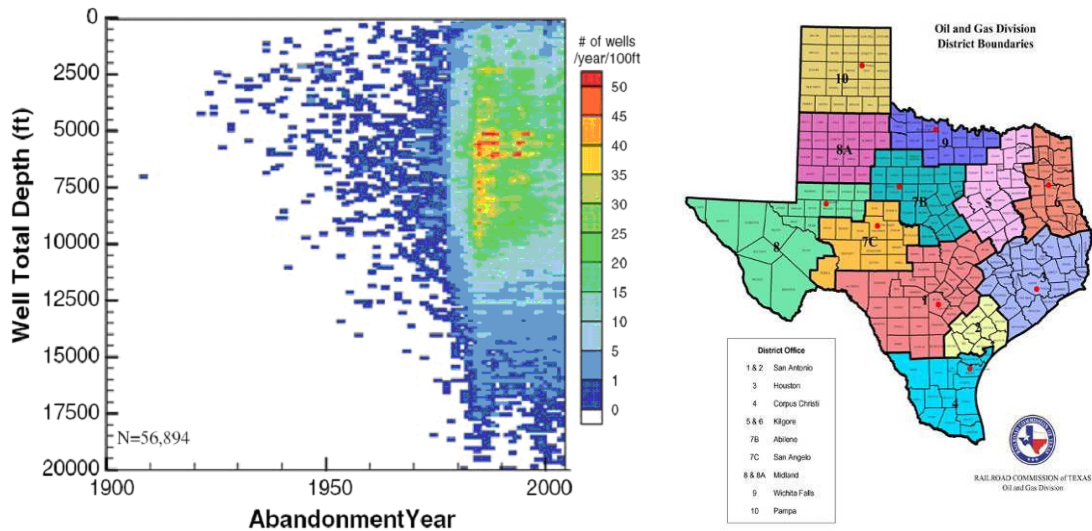

Figure 3.4 Well total depth distribution versus the year of abandonment (left) in the Texas Railroad Commission Oil and Gas Districts 2, 3 and 4 (right). After: Nicot et al. (2006b).

In Texas there is no comprehensive database incorporating all oil and gas wells ever drilled. Of all known wells in the Gulf Coast between Corpus Christi and Houston, about 30% are abandoned wells with electronic plugging records at the Texas Railroad Commission. The remainder consist of wells that are either still in operation, only have microfilm or paper plugging documentation, or no records at all (Nicot et al., 2006a). The Railroad Commission holds data on some 1.1 million well locations across Texas. However, information on some 400,000 older wells in this database is restricted to locations transferred from old maps. Furthermore, the database is not exhaustive. For instance, it comprises only 78 wells drilled before 1934, where hundreds of thousands of wells have been drilled and abandoned before the 1930s. Some of these may have been recompleted or deepened and plugged and entering the records in a later stage, while the majority likely remained unregistered. Also more recent data is lacking. Only after the implementation of the Safe Drinking Water Act in 1974 was plugging and abandonment generally reported.

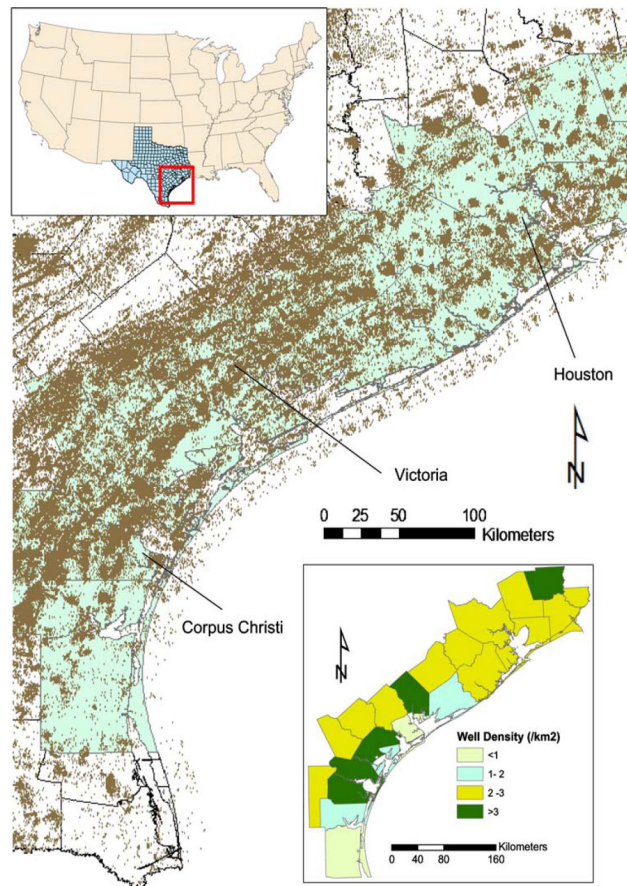

Figure 3.5 Surface well location along the Texas Gulf Coast, showing over 100,000 wells (source: RRC digital map data). Lower insert shows the average well density per county. After: Nicot, 2008.

The absence of records on many abandoned wells leads to difficulty in locating these wells. Various approaches are used to find abandoned wells if documentation is not available (Calvert and Smith, 1994), such as visual search of the area, interviews with local residents or land owners, aerial photography, or application of metal detectors. Geophysical techniques involve ground penetrating radar, electrical resistivity or infrared. Airborne geophysics was effectively applied to identify brine leakage to the surface in West Texas (Paine et al., 1999). The survey showed that shallow groundwater and surface water was significantly salinated by leakage through old wells. For 39 of the 718 wells penetrating the shallow artesian Coleman Junction formation (at 800 ft depth), mostly dating back to 1920-1960, anomalous geophysical profiles were observed matching that of a leaking well. Leakage rates through these wells were unknown (Nicot et al., 2006a).

Although the region holds abundant saline aquifers that might be suitable for carbon storage, the large number of existing wells causing multiple perforations obviously is an important issue with respect to long-term storage.

3.2.2 SACROC – field samples

3.2.2.1 Field description

The SACROC Unit is located in Scurry County, West Texas, and lies on the north eastern fringe of the Permian Basin (Figure 3.6). The Unit was discovered in 1948 as the Kelly Snyder Field. The SACROC Unit is the 7th largest onshore oil field in northern America with 2.8 billion barrels of original oil in place (OOIP). The reservoir

comprises the Pennsylvanian Cisco and Canyon formations. The reservoir is overlain by the Wolfcamp shale (Brnak et al., 2006; Gonzalez et al., 2007). The top of the reservoir is situated at about 2100 m depth and the reservoir has an average thickness of 240 m and temperature and pressure of 54°C and 18 MPa (Carey et al., 2007). The porosity is around 10% (7.6% according to Brnak et al., 2006) and permeability ranges between 10-100 mD. The main producing reservoir, the Canyon Reef limestone formation, is highly heterogeneous with non-producing zones with porosity and permeability at <2% and <1 mD (Carey et al., 2007).

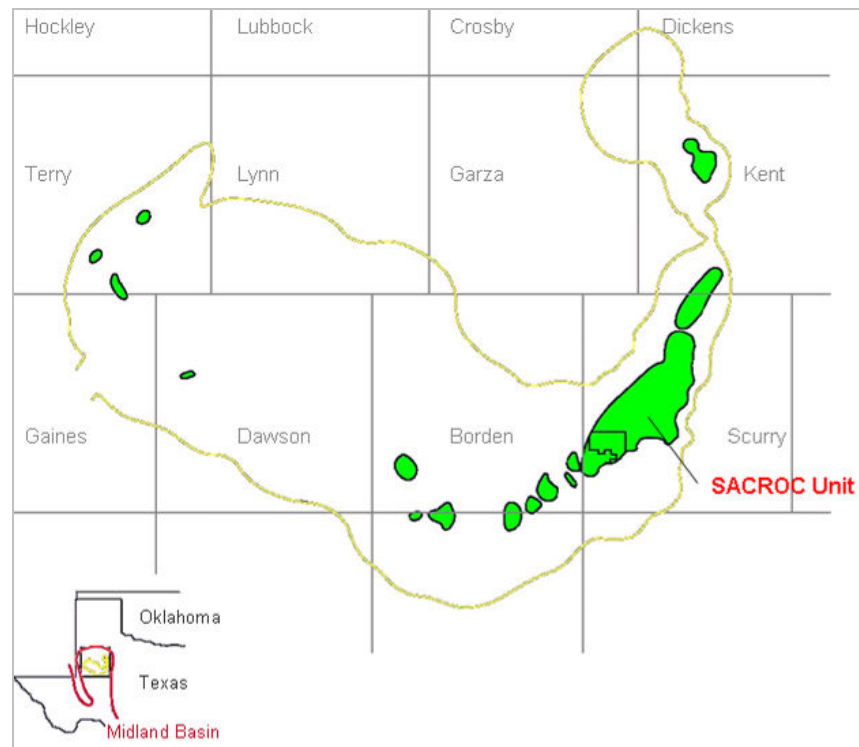

Figure 3.6 Location of the SACROC Unit, situated in West Texas. Modified after: Vest (1970) in Larkin and Creel (2008).

By 1952, 1,200 wells had been drilled in the SACROC Unit by 400 different operators. As pressure declined rapidly, a water flooding operation was started in 1954 to counteract the pressure drop and to improve oil recovery (Larkin and Creel, 2008). In 1972 CO₂ flooding commenced together with the injection of H₂S. Shortly thereafter the unit's oil production peaked with rates exceeding 200,000 barrels per day (Brnak et al., 2006). Since 1972, 68 million metric tonnes of CO₂ have been effectively sequestered (Carey et al., 2007). The SACROC unit thus holds wells that have been in contact with CO₂ for over 35 years. This provides an excellent opportunity to investigate the behaviour of well materials under influence of CO₂ under reservoir conditions. To this purpose side-core samples, consisting of casing, primary cement and caprock, were retrieved just above the reservoir-caprock contact by Carey et al. (2007).

3.2.2.2 Field samples

Carey et al. (2007) investigated CO₂-cement interactions and its impact on cement performance on the base of wellbore samples. Side-core samples were taken from well 49-6, located in the northern region of the reservoir. This well was drilled in 1950 to a depth of 2131 m, with the shale-limestone reservoir contact at 2000 m. The analyzed cement samples were retrieved from a depth of 1994-2000.1 m. At this depth THE casing was cemented during the completion stage, apparently using a neat Portland cement with density 1857 kg/m³, probably of Class 1 cement, equivalent to API Class A

(Carey et al., 2007). Subsequently an acid stimulation using 477,000 l of HCl was performed. The well was exposed to injected CO₂ for the first time in 1975, functioning as a production well for 10 years and as an injector for 7 years. Alternatively, small amounts of CO₂ may have been introduced to the well much earlier in its life cycle by generation from the initial acid stimulation (Carey et al., 2007).

The cross section, which was reconstructed from the samples by Carey et al. (2007), comprises casing, cement and shale caprock (Figure 3.7). Upon retrieval the casing was found to be in excellent condition showing little evidence of corrosion. This is in agreement with evaluation by Crow et al. (2008) of core samples retrieved from a natural CO₂ production well as well as corrosion log data indicating minimal wall thickness losses. All 20 K-55 carbon steel casing samples were in excellent condition with only limited corrosion. In contrast to the intact casing the cement of the SACROC field sample, however, is characterized by two distinct alteration zones of the cement.

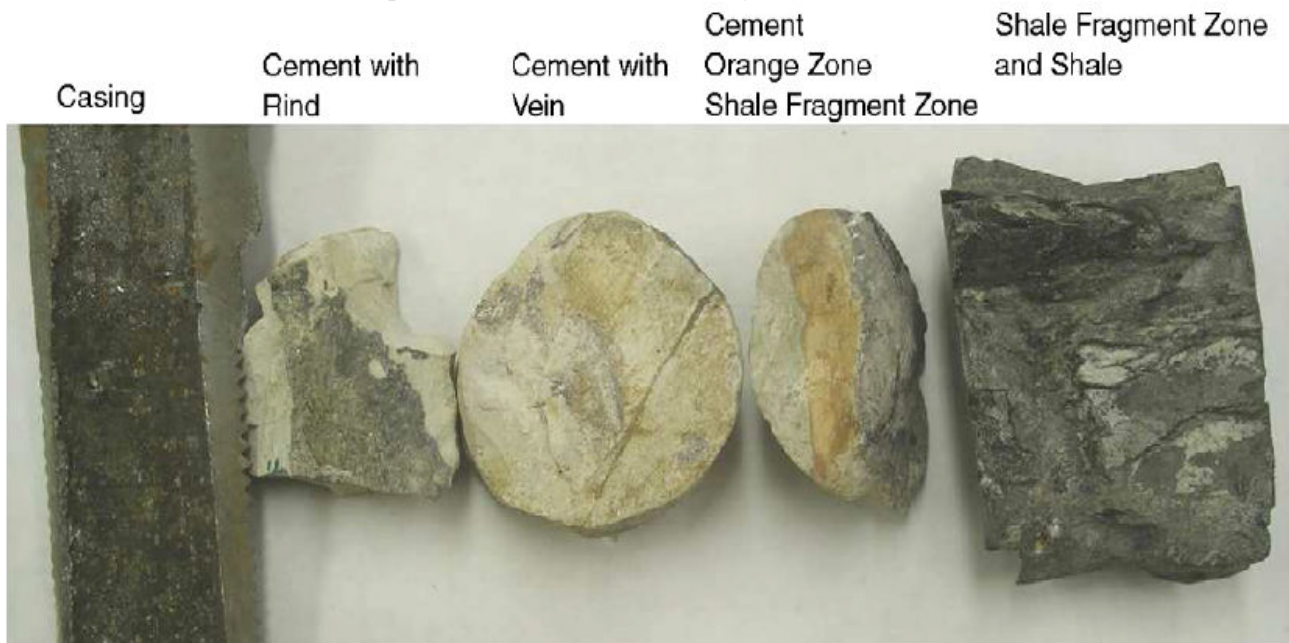

Figure 3.7 Photograph of samples retrieved from well 49-6, showing (from left to right) casing, cement with alteration zones at both interfaces, a zone of fragmented shale and shale caprock (Carey et al., 2007).

The first zone forms a 1-3 mm thick dark calcite-aragonite rind between the casing and cement. Furthermore, a carbonate vein is deposited against the casing. The CO₂ that caused these deposits could have migrated along the casing-cement interface or may have penetrated from the inside of the casing (e.g. via casing threads or corrosion pits).

The intact cement has a measured porosity of 33.5%, which is typical for Portland cements, and air-dried permeability of 0.1 mD. It shows a subparallel set of fractures, filled with calcium carbonate, that could be associated with induced stresses and differential pressures during the subsequent production and injection phases. No pervasive flux of CO₂ could have affected the grey cement as apart from calcite and aragonite, also the rapidly reacting portlandite is still present in the sample (Carey et al., 2007).

Between the unaltered cement and the shale caprock a 1-10 mm thick intensely carbonated orange alteration zone can be observed. All of the portlandite in this zone is consumed. It now consist of an amorphous component (about 50%) and three calcium carbonate polymorphs (calcite, aragonite and vaterite), indicating a strong supersaturation of the carbonating fluids. Permeability of this zone is similar to that of

the intact cement (i.e. air-dried permeability of 0.2 mD, corresponding to Klinkenberg-corrected value of 0.01 mD under confining pressures up to 27.6 MPa). The texture indicates that CO₂ was supplied along the cement-shale interface. The interface between this zone and the cement is formed by a narrow (<1 mm) dark grey deposit of amorphous silica, silica-carbonate and carbonates that may reflect successive carbonation fronts. The dense zone appears to form a continuous barrier between the altered and gray cement zones (Carey et al., 2007).

Finally, between the altered cement and the shale a complex zone of shale fragments embedded in a fine-grained matrix composed of drilling residue mixed with cement (comprising calcite, aragonite, dolomite, silica and significant amounts of halite). The zone is characterized by fragmented shale that contains zones of high or open porosity. Therefore it seems plausible that CO₂ migrated from the reservoir through the fragmented shale zone rather than along the shale interface.

The bonding between cement and casing was not preserved anywhere, probably as a result of the retrieving method, but could also be detached before sampling (Carey et al., 2007). In the latter case, however, there are no indications that any fluids migrated along these cracks. This observation is supported by the interpretation of a cement bond log (CBL) that shows adequate bonding of cement to both casing and shale from the top of the reservoir (at 2000 m) to 1950 m.

The analysis of the annular cement (Portland Class H, with 50% fly ash, 3% Bentonite gel; 1710 kg/m³) of a natural CO₂ producer after 30 year well life by Crow et al. (2008) shows that cement cores close to the CO₂ reservoir (at 1430 m measured depth and 58°C, 10 MPa) were almost completely converted to calcium carbonate. Average porosity and permeability were measured at 41% and 21 μD. In contrast, samples taken from the top of the caprock (at 1372 m MD) display minimal alteration and porosity and permeability of 25% and 1 μD. Cement interfaces with both casing and caprock show apparently tight contacts without alteration zones or debris (Figure 3.8). However, a Vertical Interference Test (VIT) between two perforated intervals shows evidence for some hydraulic communication, likely along the interfaces (Crow et al., 2008).

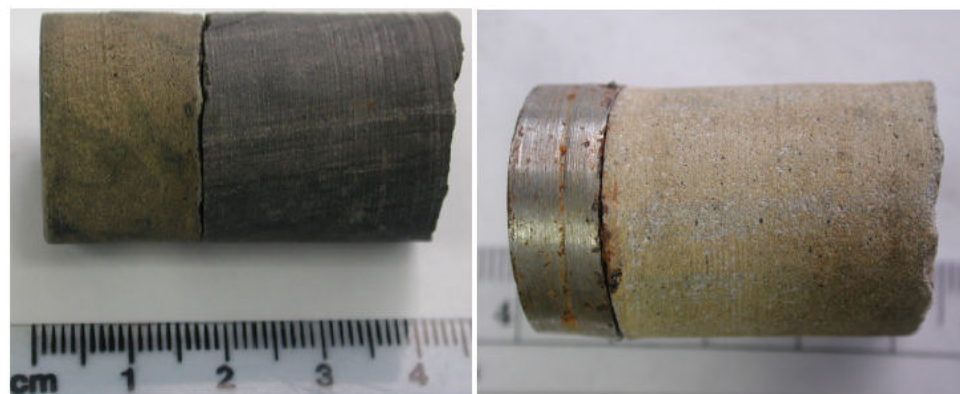

Figure 3.8 Core samples from a natural CO₂ producer taken at 1427 m MD (left) and 1417 m MD (right), showing tight fits at the cement-formation and casing-cement interfaces, respectively. After: Crow et al. (2008).

Carey et al. (2007) conclude that the cement at the SACROC 49-6 well survived and retained its structural integrity after 30 years under influence of CO₂. Similar conclusions are drawn by Crow et al. (2008) evaluating cement from a natural CO₂ producer. In spite of the somewhat enhanced permeability with respect to virgin Portland cement, the cement in both investigated wells is expected to provide adequate resistance against significant CO₂ migration through the cement matrix. On the other hand migration along the interfaces between cement and both casing and caprock seems

to have occurred, leading to the observed alteration zones. Therefore, the integrity of these interfaces appears to be the most critical aspect in well integrity for geological CO₂ storage.

3.3 The Alberta Basin (Alberta, Canada)

The Alberta Basin in western Canada is a mature sedimentary basin, hosting large oil and gas fields. Hydrocarbon exploration started in the late 19th century and the oldest recorded abandoned well dates back to 1893. Drilling and production regulations were not in place before 1938. Upon a major oil discovery in 1947, rapid growth followed that continues until today following the oil and gas market economical cycle (Bachu and Watson, 2006). Over 320,000 wells have been drilled, with drilling rates of 12,000 wells per year over the last decade (Gasda et al., 2004; Figure 3.9). The Alberta Basin shows a very high quality and complete database on oil and gas wells. The database holds data on all deep wells and is managed by the Alberta Energy and Utilities Board (Bachu and Watson, 2006). In western Canada, similar to elsewhere around the world, current practice in oil and gas industry involves well monitoring during its active lifetime, while no monitoring is required after adequate abandonment is reported (Gasda et al., 2004).

3.3.1 *Spatial and temporal characterization of wells*

Gasda et al. (2004) performed a quantitative characterization of wells penetrating the Viking Formation, which contains approximately 5% and 8%, respectively, of oil and gas reserves in the Alberta Basin. The Viking Formation forms a wedge-shaped interval dipping to the southwest. Along its western boundary the formation is deepest exceeding 3000 m depth. Towards the outcrop in the northeast, the burial depth gradually decreases. Over 200,000 wells were drilled to penetrate or transect the Viking Formation, resulting in an average well density of 0.48 wells/km². Of the existing wells 31% is active (either production, injection or disposal wells), while 68% is inactive (standing, suspended or abandoned) (Gasda et al., 2004). Figures for the entire province of Alberta show that 51% of the wells is active, whereas the remainder is abandoned or inactive/suspended, i.e. 34% and 15%, respectively (Bachu and Watson, 2006). In spite of the favourable potential CO₂ storage capacity and infrastructure in the Alberta Basin, the abundance of existing wells could pose a risk for long-term storage.

The spatial distribution of wells obviously is determined by the location of oil and gas reservoirs. As a result, clusters of high well density exist around known hydrocarbon fields. The surface expression of the wells is complicated by the presence of stacks of reservoirs: adjacent wells may be aimed at different vertical levels that contain hydrocarbons. Gasda et al. (2004) show that approximately one third of the wells in the Viking Formation is situated in high to very high density clusters. It should be noted that zones showing very high densities (involving 5.2% of the wells) are typically associated with heavy oil recovery, as production techniques require closer spacing of well relative to less viscous oil or gas. In the Alberta Basin heavy oil is generally found in horizons that are too shallow for potential long-term CO₂ storage (Gasda et al., 2004). As a result the clusters showing the highest densities will not impede carbon storage. The lower well density regions show relatively many dry holes, i.e. unsuccessful exploration wells that were abandoned immediately after drilling.

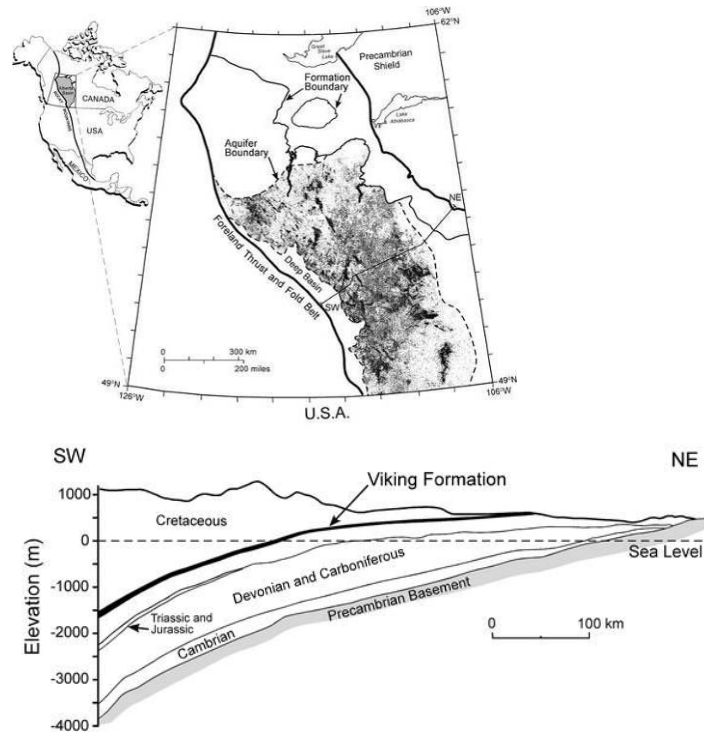

Figure 3.9 Location of the Viking Formation in the Alberta Basin, Canada, showing the location of all wells penetrating the formation (left) and a cross-section of the Alberta Basin (right). After: Gasda et al., 2004.

These wells generally do not include a steel casing and plugging is performed in the open hole. Approximately 50% of wells in the lower density areas is classified as abandoned (Gasda et al., 2004). Throughout Alberta, roughly 50% of the abandoned wells were drilled and abandoned without production casing in place (Bachu and Watson, 2006).

The temporal evolution of wells penetrating the Viking Formation reflects the general production developments in the Alberta Basin, starting in the late 19th century. Drilling activity rapidly increased after a major oil discovery in 1947. Subsequently, the number of wells drilled steadily increases with approximately 60,000 well per decade, peaking with 12,000 wells per year over the last years. The continuous development of exploration and production results in higher well densities, especially for wells now classified in lower density areas.

The observations above illustrate the significant differences in well density and therefore in the number of wells that could potentially be impacted by CO₂ storage, depending on the location of injection. Based on this, CO₂ injection would be preferred in low well density areas. On the other hand, storage operations could economically benefit from the better infrastructure that already exists in areas with larger well clusters.

3.3.2 Failure of oil and gas wells

Historically wellbore construction mainly focused on the production of economic, conventional hydrocarbon reservoirs. As a result little attention was paid to unconventional resources, such as coal bed methane and shale gas, which in Alberta typically are situated at relatively shallow levels (Bachu and Watson, 2006). In many cases, well cementing was not required at these levels, leading to the absence or inadequacy of the primary cement sheath. Since the implementation of the Oil and Gas Act in 1949, well cementing of deeper formations is required. As a result, leakage of shallow gas resources through or along the wellbore is observed by sustained casing pressure or soil gas migration outside the surface casing. In 70% of the reported cases of well leakage, the gas originated from depths less than 500 m, while approximately 90% was derived from less than 700 m depth (Bachu and Watson, 2006). Although sustained casing pressure and gas migration originate from shallower formations, these kind of well failures could provide leakage pathways to the surface once zonal isolation or casing fails (Bachu and Watson, 2008).

Reported incidences of sustained casing pressure or gas migration by operators since 1995 indicate that these types of leakage can be caused by the absence of cement, degradation by formation fluids, deformation resulting from swelling clays or (thermal) stimulation and production operations, or poor cementing jobs especially in deviated wells (poor mud removal, cement shrinkage, cement contamination or poor curing). Of the approximately 316,500 wells recorded by the Alberta Energy and Utilities Board, Bachu and Watson (2006) reported that 3.9% sustained casing pressure, 0.6% showed gas migration and 0.1% showed both phenomena. Well leakage is higher in cased wellbores than in open-hole wells (i.e. 6.1% and 0.5%, respectively), possibly due to historically more stringent regulations (requiring multiple abandonment plugs) on open-hole well abandonment (Figure 3.10).

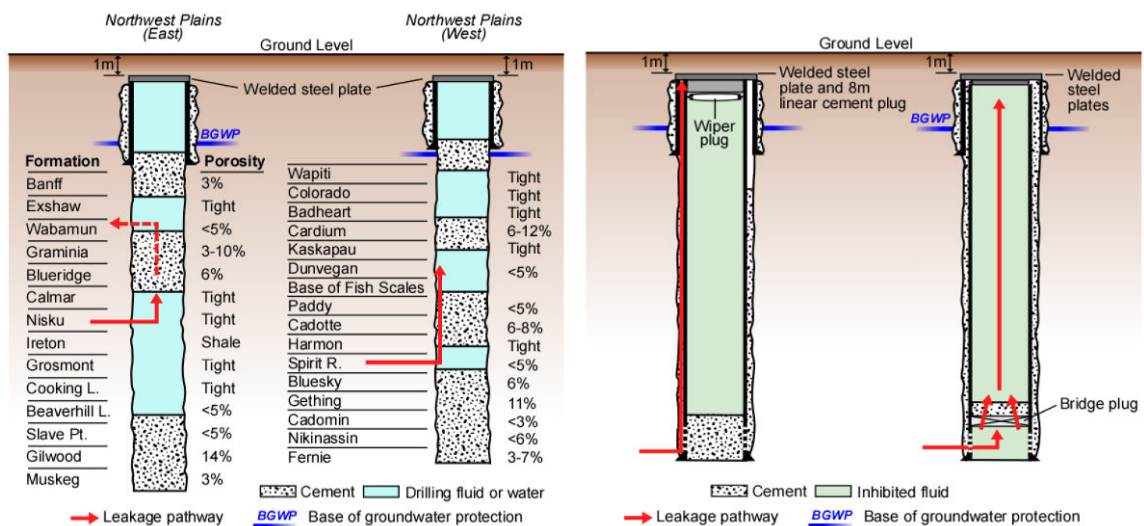

Figure 3.10 Typical well abandonment configurations in Alberta, Canada, showing drilled and abandoned open-hole wells (left) and cased, completed and abandoned wells (right). After: Watson and Bachu, 2007.

Barclay et al. (2001) described remedial cementing to seal small gas vents in wells in Alberta, using an ultralow-rate squeeze-cementing technique. In single wells in different fields two subsequent conventional squeeze jobs failed to eliminate gas migration. Application of ultralow-rate squeeze operations with advanced cement, using

optimized particle-sized distributions, lead to the successful permanent abandonment of both wells.

Since the 1950's observed gas migration and sustained casing pressure are mainly governed by intensive drilling of newly discovered resources, oil price developments and advances in regulatory demands (especially in the late 1960's) or technology. Immediate repair of well leakage is required for serious leakage, i.e. high leakage rates exceeding 300 m³/day, high pressure build-up compared to hydrostatic gradient, or leakage of liquids or sour gas. Non-serious leakage repairs may be postponed to abandonment of the well. It should be noted that only 2% of recorded leakage cases showed rates over 300 m³/day and 0.8% involved flow of liquids (Bachu and Watson, 2006).

Watson and Bachu (2008) investigated abandoned wells in Alberta, Canada, and found that only 50% of the wells with a cement plug placed using the dump bailer method were intact. This high rate of failure is believed to be caused by mechanical failure of the bridge plug. Therefore, this abandonment method seems less secure, leaving plugs with shorter expected life relative to other plugging methods (Watson and Bachu, 2008).

3.3.3 *Failure of CO₂ and acid gas wells*

The first CO₂-EOR operation in Alberta was performed in 1981. In 2008 at seven sites CO₂ stimulation is used to enhance oil recovery. The first acid disposal operations started in 1991. However, only in 1994 a provincial directive was implemented, governing Class III injection and disposal wells by the requirement of hydraulic isolation of the reservoir zone and cementing over intervals bearing groundwater resources. Approximately half of the CO₂ injection wells and most acid gas disposal wells were drilled after 1994, showing distinctively lower failure rates compared to wells drilled prior to the improvement of regulatory requirements.

Bachu and Watson (2008) reviewed failure of wells associated to CO₂-EOR (31 wells) and acid gas disposal operations (48 wells) in Alberta (Figure 3.11). Most CO₂ and acid gas injection wells are converted from existing wells that were originally drilled for different purposes. In the majority of evaluated wells conventional materials (e.g. Class G neat or bentonitic cement, J55 or K55 steel grade) were used in well construction. In 19 wells sulphur-resistant casing material (i.e. L80 or N80) was applied.

Different types of well failure were recognized, distinguishing various sections or equipment of the wellbore, in order to allow adequate comparison of the results against previous studies of the general well population in Alberta. Reviewed categories of well failure comprise tubing and/or casing failure, packer failure, zonal isolation failure, and sustained casing pressure or gas migration outside the surface casing (Bachu and Watson, 2008).

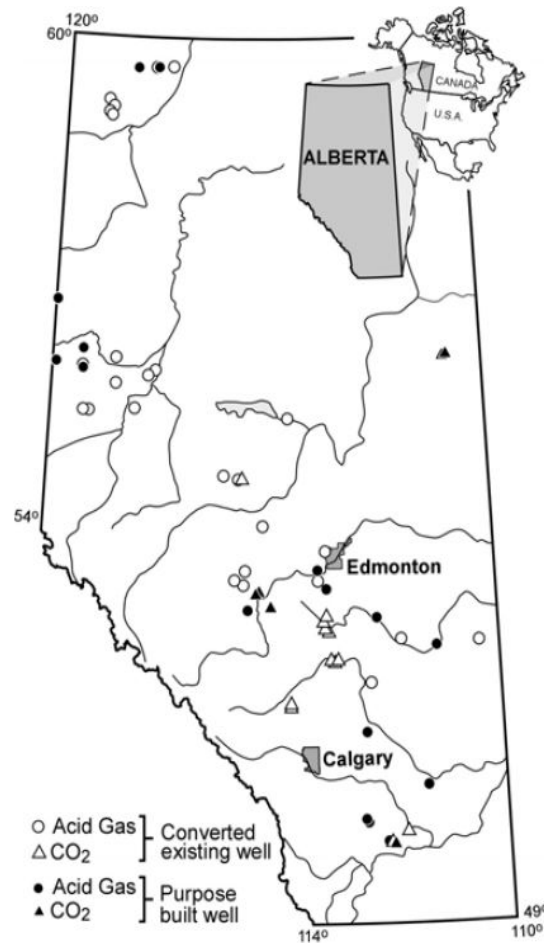

Figure 3.11 Locations of acid gas and CO₂ injection wells in Alberta, Canada, in 2008. After: Bachu and Watson, 2008.

In contrast to casing failure and sustained casing pressure that were predominantly observed in the general population of deep wells, the majority of well failures associated with acid gas and CO₂ injection wells is caused by tubing and packer failures. Furthermore, converted wells are recorded to be more prone to wellbore failure than in wells drilled for purpose, presumably as a result of better cementing at the top section of the well. Comparing acid gas disposal wells and CO₂ injection wells, the former show lower failure probabilities, most likely due to more stringent design standards and maintenance standards. For both types of operations wells built for purpose show significantly lower failure rates. It should be noticed that this is mainly due to the occurrence of sustained casing pressures and gas migration and therefore not directly related to the injection operations (Bachu and Watson, 2008).

4 Impact of CO₂ on wellbore integrity

In spite of the many similarities of hydrocarbon production and temporal storage and geological storage of CO₂, several significant contrasts between these activities have to be recognized. The distinct characteristics of CO₂ storage operations include the repressurization of subsurface formations, the purpose of long-term containment (i.e. thousands of years) and the potential chemical interaction of aqueous CO₂ with formations and well materials. This chapter describes the potential impact of CO₂ injection on the wellbore and well cement and steel.

4.1 Potential CO₂ leakage mechanisms

Based on a review of natural and industrial analogues for CO₂ storage, Benson et al. (2002) concluded that the most important cause of failure of an injection well is the application of well construction materials that were incompatible with the injected fluids, leading to excessive casing corrosion. Alternatively, failure was reported to result from well mechanical flaws, damage to the well as a result of excessive injection pressures, inadequate monitoring of annulus pressure or lack of detection of fluid migration behind the casing (Benson et al., 2002). In general, several mechanisms can give rise to leakage of fluids along the well system as illustrated in Figure 4.1.

As wet CO₂ or CO₂ in solution are corrosive fluids, specific attention is required for chemical degradation of well materials in CO₂ storage projects. The combination of CO₂ and water will result in both chemical degradation of the oil well cement (e.g. Bruckdorfer 1986, Scherer et al. 2005, Barlet-Gouédard et al. 2006), thereby potentially enhancing porosity and permeability, and corrosion of the casing steel, creating pathways through the steel.

Mechanical deformation of cement, casing material or host rock due to operational activities (e.g. drilling, pressure and temperature cycles) or natural stresses can result in the development of cracks or shear strain, enabling highly permeable pathways through these media to develop (Ravi et al., 2002a; Shen & Pye, 1989). Furthermore, the loss of bonding between different materials (also called debonding) could cause annular pathways along the interfaces between casing, cement or host rock. This process could result from a poor cement placement job or cement shrinkage. Volumetric shrinkage of cement upon placement of 4% is not uncommon in oil and gas industry.

Cementing is critical to the mechanical performance and integrity of a wellbore both in terms of its method of placement and the type or class of cement used. In practice, a good quality of cement plugs and primary cement sheath has to be confirmed by e.g. (pressure/weight) testing, log data and drill-off performance. The primary cement sheath both prevents behind-casing flow of fluids as well as protects the casing from corrosion by e.g. aqueous CO₂ or brines, not only at seal levels, but also at shallow depths (Watson & Bachu, 2007). It is sensitive to flaws resulting from e.g. bad mud removal, decentralized casing (especially in deviated wells), non-optimal placement (for details see Barclay et al., 2002), or cement failure under stress. Even a good cement bond log (CBL) is no guarantee for a channel-free cement sheath (Carey et al., 2007; Watson & Bachu, 2007).

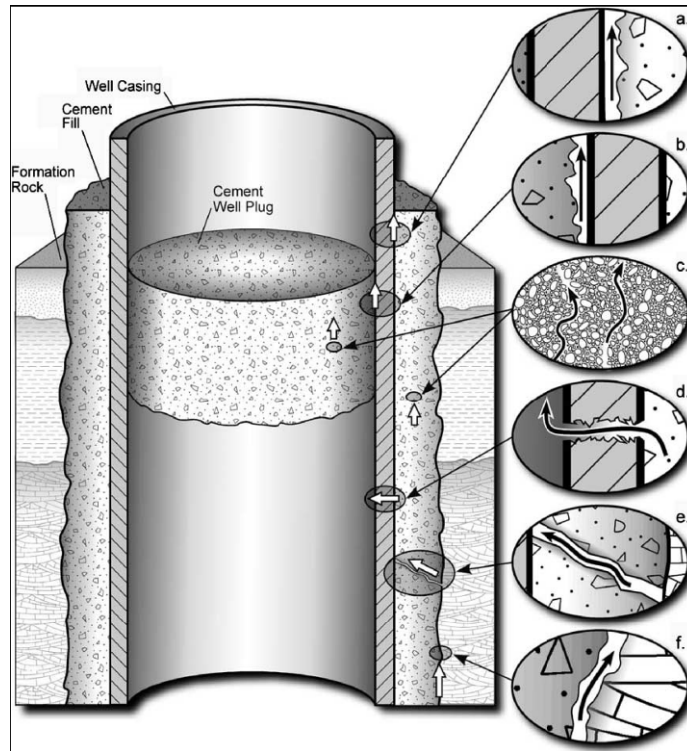
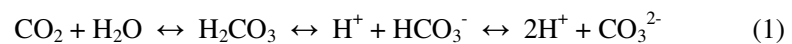

Figure 4.1 Potential leakage pathways through an abandoned well: (a) along the casing-cement interface; (b) along the cement plug-casing interface; (c) through the cement pore space as a result of cement degradation or fracturing; (d) through casing as a result of steel deformation or corrosion; (e) through fractures in cement; and (f) along the cement-rock interface. After Gasda et al. (2004).

4.2 Chemical degradation of wellbore cement

4.2.1 Chemical degradation mechanism

Although CO₂ itself is not corrosive, in combination with water (either wet supercritical CO₂ or CO₂ dissolved in water) CO₂ dissociates to form carbonic acid:



After dissolution of CO₂, cement degradation commences with the progressive consumption of the solid cement constituents Portlandite (Ca(OH)₂(s)) and Calcium Silicate Hydrates [C-S-H(s)] to produce carbonates (aragonite, vaterite and/or calcite), amorphous silica gel (SiO_xOH_x) and water. This stage is called ‘carbonation’:

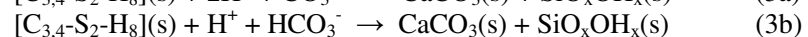
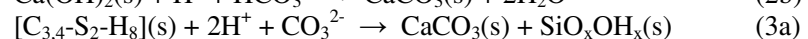

Note that in the presence of magnesium ions in the formation water, also dolomite (CaMg(CO₃)₂) will be formed.

The progressive dissolution of C-S-H creates a high-porosity ‘dissolution front’ in the cement (Figure 4.2). The produced calcium carbonates precipitate at the ‘carbonation

front' reducing the porosity. During the subsequent 'leaching' step, the calcium carbonate could be again dissolved by the CO₂-brine ('dissolution back-front' in Figure 4.2), increasing the porosity and resulting in a strong degradation of the cement:

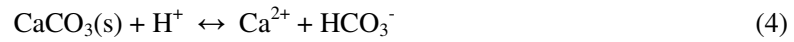

The entire cement degradation process as observed in the laboratory is formed by three subsequent steps that result in the distinct formation of progressive zones of alteration in samples under CO₂ attack as shown in Figure 4.2 (Barlèt-Gouédard et al., 2006). During the cement carbonation stage the porosity of the cement is reduced by precipitation of calcium carbonates. If the permeability is reduced as well this process is likely to have a decelerating effect on the diffusion rate of CO₂ (WBIN4, 2007). However, supply of additional CO₂ may again lead to dissolution of CaCO₃ during the leaching stage. The final result of this total degradation process would then be an amorphous silica gel. Rimmelé et al. (2008) found that also the apparent unaltered inner part of the sample rapidly reacted in the first days of exposure, leading to increased porosity and sporadic calcite precipitation throughout the sample.

Note that the combination of chemical reactions (1) to (3) involves no net increase or decrease of H⁺ ions in the solution. Upon consumption of hydrogen ions in reactions (2) and (3), supply of H⁺ ions is warranted by dissolution of CO₂ according to reaction (1). Hence, no net effect on pH is expected from these reactions. However, if dissolution of calcium carbonate according to reaction (4) is incorporated, the pH would increase. Obviously, the occurrence of these reactions is governed by the chemical equilibrium. Due to the anticipated surplus of CO₂ and its dissolution products from reaction (1), reactions (2) and (3) are expected to shift to the right-hand side. The occurrence of reaction (4) is less straightforward and the composition of the formation water will have an important effect on this 'leaching' step.

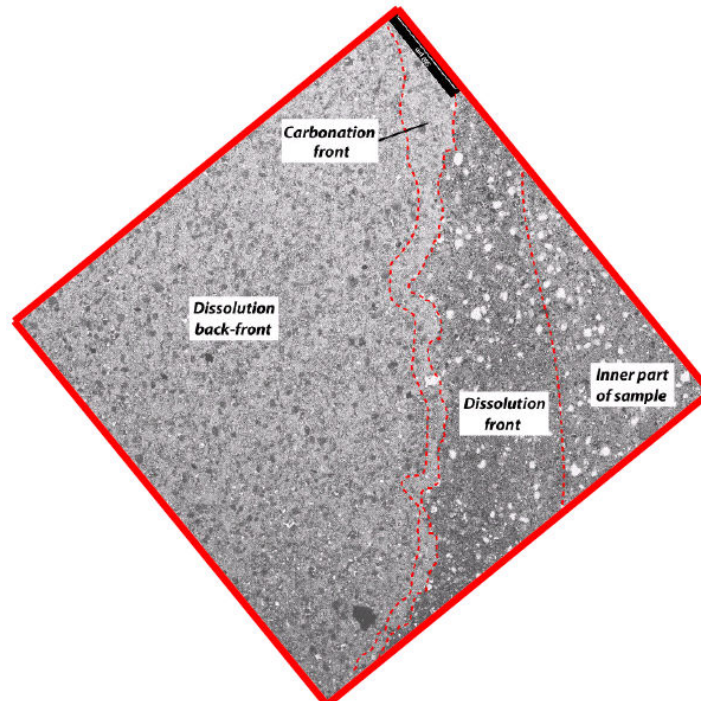

Figure 4.2 Back-scattered electron image of a Portland cement sample after degradation in a water-saturated supercritical CO₂ fluid. After Barlèt-Gouédard et al. (2006).

At present the range of the permeability of degraded cement remains unclear. Although some authors indicate a relatively low permeability in the order of micro- to milli-Darcy based on laboratory experiments (e.g. Barlet-Gouédard et al., 2006; Duguid et al., 2006; Lécolier et al., 2006) and on field observations over a maximum of 30 years of exposure to CO₂ (Carey et al., 2007), it is uncertain how the permeability will develop over longer time scales. Furthermore, it has been established that the remaining amorphous silica gel has an extremely low strength. As a consequence it will be easily washed out by fluid flow or deformed when pressure gradients or buoyancy would be applied.

The w/c (water to cement) ratio of Portland cements has a major impact on the resistivity of cement to acid attack (e.g. Bruckdorfer 1986, Van Gerven et al. 2004). This ratio has to be kept as low as possible in order to keep the cement porosity and permeability low and to avoid capillary forces driving CO₂ into the cement. If less viscous cements are needed in the field, the use of plasticizers is beneficial over adding water.

Experiments on the effects of cement additives returned mixed results. Some results indicated that addition of fly ash increases the degradation rate of cement significantly (WBIN4, 2007) or at least does not improve carbon dioxide resistance (Bruckdorfer, 1986). Bentonite, another commonly used additive, was found to dramatically decrease the cement's resistance to acid attack (US DOE, 2006). Strazisar et al. (2008) studied the effect of Halliburton Pozmix A - a Class F fly ash - on material degradation under influence of CO₂, qualitatively comparing results of similar experiments on 65:35 and 35:65 pozzolan-cement mixtures. While the 35:65 pozzolan-cement sample displayed phenomena probably associated with precipitation of calcium carbonate at the sample's rim, presumably the 65:35 sample was entirely carbonated. However, neither sample showed significant alteration of its physical properties (Strazisar et al., 2008). On the other hand, Halliburton found that a 50:50 mixture of pozzolan and Portland cement is less susceptible to carbonic acid leaching and maintains a lower permeability over a longer period of time compared to formulas composed entirely of Portland cement (Onan, 1984).

4.2.2 *Degradation rates*

Numerous literature references deal with cement degradation under influence of CO₂ (e.g. Barlet-Gouédard et al., 2006; Bruckdorfer, 1986; Duguid et al., 2004; 2006; Duguid, 2008; Lécolier et al., 2006; Shen and Pye, 1989; Van Gerven et al., 2004) allowing for estimation of cement degradation rates under in-situ reservoir conditions. An inexhaustive summary of experimental results reported in literature is presented in Table 4.1.

Diffusion of CO₂ into the pores of the cement is considered to be the rate-controlling step in cement degradation (e.g. Garcia-Gonzalez et al., 2006; Duguid, 2008). However, not all authors presented diffusion coefficients from their results. For these studies, coefficients were estimated based on the reported results of penetration depth versus time. Reported and derived coefficients based on experiments at different conditions are summarized in Table 4.1 to aid comparison of the different results. Results from Barlet-Gouédard et al. (2006) show that degradation under influence of water-saturated supercritical CO₂ is somewhat faster than under influence of dissolved CO₂. In general degradation rates increase when cement is exposed to CO₂ at higher temperature or lower pH conditions. Kutchko et al. (2007) showed that also the curing conditions determine the cement's susceptibility to degradation: curing at higher temperature and pressure results in reduced penetration, relative to samples hardened at lower temperature and/or pressure.

Table 4.1 Comparison of cement degradation rates from literature references

Reference	C^1 ($\text{mm} \cdot \text{h}^{-1/2}$)	Time (yr) for 25 mm of cement degradation	CO ₂ penetration depth (m) after 10 ⁴ yr	Cement type	P (bar)	T (°C)	pH	w/c ratio	Carbonation medium
Barlèt-Gouédard et al. (2006)	0.2622	1.0	2.45	Portland Class G	280	90	-	0.44	Static water-saturated supercritical CO ₂
	0.2182	1.5	2.04	Portland Class G	280	90	-	0.44	Static CO ₂ -saturated water fluid
Bruckdorfer (1986)	0.0623	18.4	0.58	Portland Class A	206.8	79.4	-	0.38	Static wet supercritical CO ₂
	0.0513	27.1	0.48	Portland Class C	206.8	79.4	-	0.38	Static wet supercritical CO ₂
	0.0770	12.0	0.72	Portland Class H	206.8	79.4	-	0.38	Static wet supercritical CO ₂
	0.0843	10.0	0.79	Portland Class H plus 50% fly ash	206.8	79.4	-	0.38	Static wet supercritical CO ₂
Carey et al. (2008) ²	0.0126	450	0.12	'Portland cement'	140/ 280 ³	40	7.8-7.6	-	Flowing CO ₂ -brine (25,000 ppm NaCl, 4,000 ppm CaCl ₂ , 1,000 ppm MgCl ₂ , 200 ppm MnCl ₂)
Duguid et al. (2004)	0.0336	63.2	0.31	Portland Class H	1	50	5.03	0.38	Flowing carbonated brine (0.5M NaCl solution)
	0.0250	114	0.23	Portland Class H	1	50	4.78	0.38	Flowing carbonated brine (0.5M NaCl solution)
Duguid et al. (2006)	0.0121	487	0.11	Portland Class H	1	23	3	0.38	Berea sandstone with static carbonated brine (0.5M NaCl)
	0.00534	2,500	0.05	Portland Class H	1	23	-	0.38	Berea sandstone with static carbonated brine (0.5M NaCl)
Duguid (2008) ⁴	0.00146	33,381	0.014	Portland Class H	1	20	3	0.38	Berea sandstone with static carbonated brine (0.5M NaCl)
	0.00159	28,300	0.015	Portland Class H	1	50	3	0.38	Berea sandstone with static carbonated brine (0.5M NaCl)
	0.00031	724,281	0.003	Portland Class H	1	20	5	0.38	Berea sandstone with static carbonated brine (0.5M NaCl)

¹ C = constant factor in Fick's Second Law describing diffusion: $d = C \cdot t^{1/2}$, where d in [mm]; t in [h]. Note that these values are estimated from results on CO₂ penetration depth versus time: these C-values are not given in the references (except for Barlèt-Gouédard et al., 2006).

² Experiment performed on composite sample of steel and cement with CO₂-brine flow along the annulus. Diffusion coefficient is based on the assumption of 1-D diffusion perpendicular to the annular flowpath.

³ 140 bar pore pressure, 280 bar confining pressure

⁴ Presented diffusion coefficients (C) from Duguid (2008) reflect reduced degradation rates observed after 2 to 3 months.

Reference	C^5 ($\text{mm} \cdot \text{h}^{-1/2}$)	Time (yr) for 25 mm of cement degradation	CO ₂ penetration depth (m) after 10 ⁴ yr	Cement type	P (bar)	T (°C)	pH	w/c ratio	Carbonation medium
Kutchko et al. (2007)	0.04014	44.2	0.38	Portland Class H	303	50	2.9	0.38	Static carbonated brine (1% NaCl), cured at 22°C, 1 bar
	0.03062	76.1	0.29	Portland Class H	303	50	2.9	0.38	Static carbonated brine (1% NaCl) , cured at 22°C, 303 bar
	0.03198	69.7	0.30	Portland Class H	303	50	2.9	0.38	Static carbonated brine (1% NaCl) , cured at 50°C, 1 bar
	0.01497	318	0.14	Portland Class H	303	50	2.9	0.38	Static carbonated brine (1% NaCl) , cured at 50°C, 303 bar
Kutchko et al. (2008)	0.00329 _6	6587 ∞ ⁵	0.03	Portland Class H	303	50	2.9	0.38	Static water-saturated supercritical CO ₂
			0.002 ⁵	Portland Class H	303	50	2.9	0.38	Static CO ₂ -saturated brine (1% NaCl)
Lécolier et al. (2006)	0.5568	0.23	5.21	'conventional Portland cement'	150	120	4	0.44	Static H ₂ S-saturated brine
Shen & Pye (1989)	1.3199	0.04	12.36	Portland Class G	69	204	-	-	Static wet CO ₂ gas
Van Gerven et al. (2004)	0.7778	0.12	7.28	Portland CEM I 42.5 R	400	80	-	0.34	Flowing supercritical CO ₂

⁵ C = constant factor in Fick's Second Law describing diffusion: $d = C \cdot t^{1/2}$, where d in [mm]; t in [h]. Note that these values are estimated from results on CO₂ penetration depth versus time: these C-values are not given in the references (except for Barlèt-Gouédard et al., 2006).

⁶ Fick's Law does not fit penetration results obtained by Kutchko et al. (2008) for cement degradation by CO₂-saturated brine. Kutchko et al. (2008) successfully matched an Elovich equation of the form $d = 0.0901 \cdot \ln(t/24) + 0.1708$ where d in [mm]; t in [h].

From the results by different authors, it appears that diffusion-based chemical degradation rates of cement are relatively low. Even under very high temperatures (i.e. 204 °C at 69 bar) degradation rates would result in a maximum of 12.4 m of cement plug degradation after 10,000 years of exposure to CO₂ (Shen and Pye, 1989), assuming that diffusion processes define the degradation mechanism. Depending on the governing abandonment regulations (See Chapter 5), cement plugs generally are required to extend beyond this length. This implies that the lower bound of prescribed plug lengths (i.e. 15 m) would only just exceed the maximum penetration depths under conditions described by Shen and Pye (1989), potentially compromising well integrity. On the other hand, many national regulations require plug lengths of 50 to 100 m, which is significantly longer than maximum observed CO₂ penetration. For these plug lengths, diffusion-controlled cement degradation in vertical direction appears to form no significant hazard, assuming wells to be properly cemented and plugged at the level of the sealing cap rock with no fractures or annuli present or induced. However, in lateral directions the 2-5 cm thick primary cement sheath may be degraded in timeframes in the order of (tens of) years, subsequently enabling CO₂ to attack the casing steel. Still it seems unlikely that significant amounts of CO₂ will flow through an adequate caprock to radially reach and affect the primary cement sheath over long depth intervals.

Lécolier et al. (2007) showed that different cement curing conditions have significant effects on its mechanical strength. Curing in a brine resulted in decreasing mechanical strengths of 20% and 50%, for static and flowing conditions, respectively. Aging in crude oil did not show any mechanical degradation. This could have serious implications for the evaluation of different experimental studies. Although tests performed with brine and pure water show similar alteration patterns, the type of fluid controlling CO₂ solubility plays a significant role in the cement degradation rate (Barlet-Gouédard et al., 2009).

Furthermore, Duguid (2008) established that after 2 to 3 months initial degradation rates are reduced to significantly lower values, possibly as a result of calcium carbonate precipitation or reflecting the switch from portlandite degradation to leaching of calcium carbonate. The author defined functions to describe the degradation rates during both of these phases according to Fick's Law ($d = C \cdot t^{1/2}$, where d is the penetration depth and t represents time). The diffusion coefficients (C) resulting from these experiments given in Table 4.1 only represent the reduced degradation rates, as these are expected to govern diffusion-based cement degradation on longer time scales (Duguid, 2008). A similar effect was observed by Kutchko et al. (2008), who also reported significant reduction of initially high penetration rates after 2 to 3 months for their cement samples subjected to a CO₂-saturated brine. They concluded that the penetration rate is retarded by a diffusive barrier of calcium carbonate, which precipitated during the CO₂ attack. However, instead of fitting two separate functions to the data, Kutchko et al. (2008) used an Elovich curve to successfully fit their results in a single relation.

4.2.3 *Relevance to in-situ degradation*

In order to translate experimental results to field cases, several limiting factors apply with respect to degradation rates. Whereas cement samples in the laboratory in certain cases were immersed in a bath of supercritical CO₂, well material in reality will be partially surrounded by reservoir rock, limiting the available reaction surface, the supply of CO₂ and the transportation of reaction products. Although some experiments were performed with cement samples embedded in rock material (e.g. Duguid et al., 2004; 2006; Duguid, 2008), this is not taken into account in all reported experiments.

Furthermore, in specific field cases, especially in depleted gas fields, the availability of water necessary for degradation is far more limited compared to the experiments. Moreover, injected CO₂ will push back the brine present in the storage formation. As dissolution will take place slowly, many wells will not come across the CO₂-water contact at or near critical levels, such as the cap rock. The presence of only connate water would significantly limit the chemical reactivity of CO₂.

Finally, higher salinity of formation water will likely decrease the solubility of CO₂ and reaction products, thus reducing cement degradation rates (WBIN4, 2007). Especially relatively high calcium concentrations in the fluid, which is often observed in field situations, will significantly reduce dissolution of calcium carbonates. This would have major consequences on the extent of well degradation. First, reduced dissolution of calcite could leave the cement in a state of low porosity and sufficient mechanical strength. No ‘dissolution back-front’ may be developed and progressive degradation may be hampered by the low porosity ‘carbonation front’. The actual occurrence of these phenomena would be strongly depending on the exact location of calcite precipitation (reactions (2) and (3)). If calcite would be transported away from the reaction front to be deposited elsewhere, the effects described above would be limited. Secondly, the pH would not be increased by these reactions, i.e. no pH buffering by cement would occur. These propositions are contrasting with observations in several experimental studies, where calcium carbonates were witnessed to be dissolved (e.g. Barlèt-Gouédard et al., 2006; Duguid et al., 2004; 2006). In this perspective it should be noted that these studies are performed in sodium chloride solutions, enabling dissolution of calcium carbonate during the final ‘leaching’ step.

Investigations of cement field samples that were exposed to CO₂ over 30 years during CO₂-EOR operations in the SACROC Unit in West Texas (Carey et al., 2007) and from a natural CO₂ producer (Crow et al., 2008) support the concept of limited leaching of calcium carbonate. Results from these studies show that CO₂ carbonation of cement is capable of healing pathways to some extent (see Section 3.2.2). In contrast to the laboratory results (by e.g. Barlèt-Gouédard et al., 2006), calcium carbonate precipitated from a saturated solution, healing fractures. These observations indicate that specific formation water chemistry may decrease dissolution of calcite and as a result reduce progressive degradation and weakening of the cement.

4.3 Corrosion of casing steel

4.3.1 Corrosion mechanism

The presence of natural or injected CO₂ in subsurface reservoirs enhances corrosion of well casing steel. Corrosion of steel is an electrochemical process that requires (1) a cathodic and (2) an anodic reaction, (3) electrical conduction by electrons and (4) transport of reaction products and reactants from and to the reaction surface by an electrolyte. At typical reservoir levels anaerobic conditions are prevalent and CO₂ may be in a supercritical state. Under anaerobic conditions the corrosion process of steel by dissolved CO₂ is dominated by the following cathodic and anodic reactions:

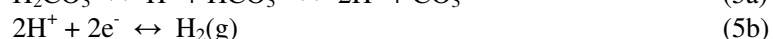
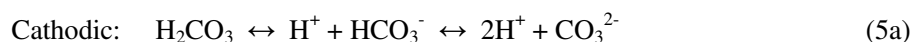

The cumulative reaction involves the formation of Fe²⁺ ions and hydrogen gas from iron metal and dissolved H⁺ ions. This mechanism involves the corrosion of iron metal

under influence of the presence of dissolved H^+ ions in combination with the formation of hydrogen gas. The gas escaping the solution drives the reactions. The electrochemical cell describing this reaction is shown in Figure 4.3.

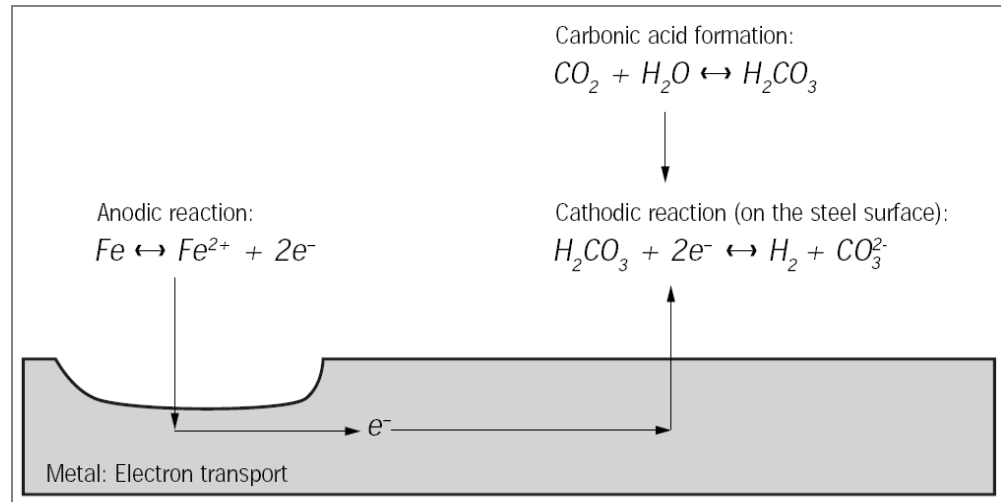

Figure 4.3 Schematic representation of an electrochemical cell for CO_2 corrosion on a steel surface, showing carbonic acid formation, an anodic reaction site with iron dissolution, metallic conduction of the electrons, the cathodic reaction with the consumption of the electrons and transport of ions and species in the electrolyte. Note that the shown cathodic reaction is composed from equilibrium reactions (1), (2) and (3), and all components of these reactions will be present in the system.

The corrosion rate of steel under aqueous CO_2 conditions is a function of temperature and partial CO_2 pressure. Under typical reservoir conditions corrosion rates could be high, i.e. in the order of ten's of mm per year (Cailly, 2005). However, wet CO_2 corrosion rates on carbon steel at high pressure are observed to be far smaller (Institute for Energy Technology in Norway supported by Statoil, as referred to by Cailly, 2005).

4.3.2 Corrosion rates

The corrosion rate of steel under aqueous CO_2 conditions is a function of temperature and partial CO_2 pressure and theoretically can be high, i.e. in the order of ten's of mm per year (Cailly, 2005). Cui et al. (2006) performed weight loss test on P110, N80 and J55 graded steel samples in simulated production water for a range of pH values of 4-6. The resulting corrosion rates decrease with the exposure time as well as with temperature. After 144 hours of exposure to CO_2 , corrosion rates are in the order of 2 mm/yr (Figure 4.4). Similar observations were made by Wu et al. (2004) on exposure of J55 steel to CO_2 leading to a rate of 1.62 mm/yr after 144 hours at 90 °C and 83 bar. With increasing temperature corrosion rates drop from initial values between 2.2 and 3.5 mm/yr at 60 °C to values between 0.7 and 1.1 mm/yr at 150 °C (Figure 4.4). Values in the same order are reported by Lin et al. (2006) from experiments with formation water. It should be noted that in general higher grade steel is more susceptible to corrosion than lower grade samples.

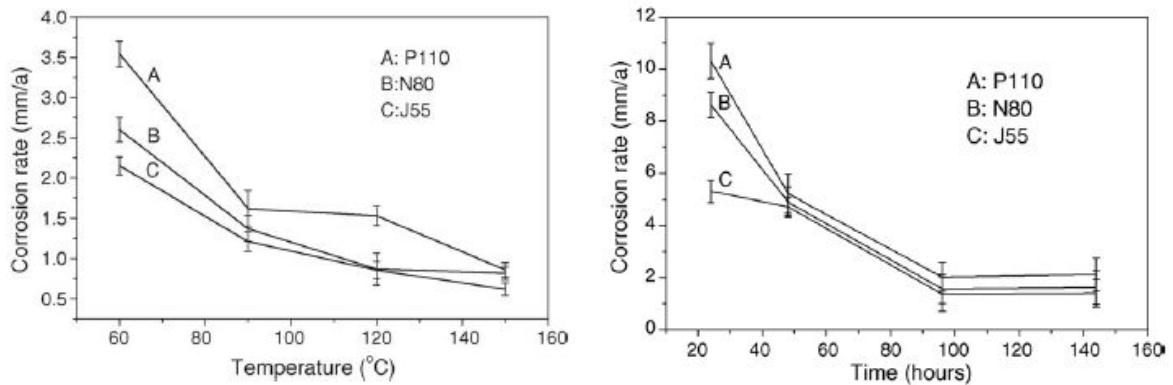

Figure 4.4 Corrosion rate dependency on temperature (left) and exposure time (right) for different steel grades. After Cui et al. (2006).

Fang et al. (2006a; 2006b) determined the influence of high salinity brines (3 wt% - 25 wt% NaCl) on the corrosion rate of C1018 carbon steel under CO₂ saturated conditions at pH 4.0 and temperatures ranging from 1 to 25°C. The high salt content retarded the anodic (dissolution of iron) and the cathodic process on the steel surface. The corrosion rates of the steel in a 10 wt% NaCl brine were 2-3 times lower compared to the corrosion rates in a 3 wt% NaCl brine.

4.3.3 Siderite precipitation

The corrosion of carbon steels under CO₂ corrosion conditions can be obstructed by the formation of a (partial) siderite (FeCO₃) layer under specific conditions (e.g. Johnson and Tomson, 1991; Van Hunnik et al., 1996). Combination of reaction products Fe²⁺ and CO₃²⁻ form iron carbonate. Having a relatively low solubility, FeCO₃ readily precipitates under favourable conditions.



The morphology of a steel surface under CO₂ corrosion conditions is primarily determined by the balance of corrosion reactions (resulting in loss of metal) and precipitation reactions (potentially protecting the underlying steel surface). If the precipitation rate exceeds the corrosion rate, a protective film forms at the metal surface which may significantly reduce corrosion rates (Xiao and Nešić, 2005). The precipitation of solid FeCO₃ occurs when the product of the concentrations of Fe²⁺ and CO₃²⁻ exceeds the solubility limit. The process takes place in two stages: nucleation and growth. Both processes are related to the level of supersaturation, i.e. the level at which the amount of dissolved material exceeds the saturation limit, which could occur for instance as a result of cooling. At a high supersaturation, iron carbonate crystals will rapidly nucleate on a large number of locations and grow fast, forming a tight and very protective surface FeCO₃ film with small crystal size (Xiao and Nešić, 2005). At low supersaturation, nucleation occurs at a significantly smaller number of locations, crystal growth proceeds slowly, resulting in very large crystal sizes. These large crystals form a much thicker and looser surface layer that is less protective and is easier damaged or washed away by fluid flow (Xiao and Nešić, 2005). Lin et al. (2006) concluded that when CO₂ pressure exceeds a critical value, the grain size and the thickness of the scale reach a minimum value.

The formation of a FeCO_3 layer is mainly governed by partial CO_2 pressure, temperature and pH. High partial CO_2 pressures or high temperatures will result in both increasing corrosion rates as well as enhanced precipitation of iron carbonate. Protective iron carbonate films have been observed in systems with high Fe^{2+} concentrations, high temperature and partial CO_2 pressure, and $\text{pH} > 5$ (Nešić et al., 2003). A general temperature dependency of the film formation was given by Burke (1984) and Palacios & Shadley (1991). While FeCO_3 precipitation at temperatures below 60 °C leads to the formation of a non-protective, porous layer on the steel surface, between 60-100 °C the film starts to show some protective properties. Above 100 °C the FeCO_3 film becomes tight and adhesive, which is even enhanced by the co-precipitation of magnetite at temperatures over 150 °C.

It is well established that to form iron carbonate films in CO_2 corrosion, the pH has to exceed a critical value, which primarily depends on temperature, Fe^{2+} concentration, and ionic strength. Corrosion data obtained from experimental investigation by Nešić et al. (2003) show that in laboratory experiments at 20 °C siderite films form very slowly, and a reasonably high pH value (> 6) and very long exposure times are required to form protective films.

4.4 Mechanical deformation of wellbore cement

The majority of experimental data on cement degradation as well as retrieved cement-casing cores from wells in CO_2 operations (see Section 3.2.2) indicate that cement is expected to provide adequate resistance against significant CO_2 migration through its matrix. Hence, it seems that the mechanical integrity of the cement plug and sheath as well as the quality of its placement could be of more significance than the chemical degradation processes (Scherer et al., 2005). Migration pathways are most likely to occur at the interfaces between cement and both casing and caprock. Therefore, the integrity of these interfaces appears to be the most critical aspect in well integrity for geological CO_2 storage (Shen and Pye, 1989; Carey et al., 2008; Bachu and Bennion, 2008), supported by evidence of CO_2 migration along these interfaces in field cases (Carey et al., 2007; Crow et al., 2008). This occurrence of micro-fractures or micro-annuli could result from poor cementing jobs (e.g. Barclay et al., 2002) or cement shrinkage (Ravi et al., 2002). This can give rise to debonding and enhanced permeability pathways resulting from e.g. cement shrinkage, poor mud removal or decentralized casing especially in deviated wells (Watson and Bachu, 2007).

Deformation on a reservoir scale can affect the mechanical integrity of the wellbore, i.e. well deformations due to decompaction of the reservoir and casing shear due to shear deformations at the reservoir-cap rock interface or at reservoir bounding faults. Reservoir pressure changes due to depletion or fluid injection can lead to wellbore casing deformation and to casing, cement sheath or plug failure, and therefore affect the integrity of existing wells.

Another important process resulting in damaged cement sheaths is the development of fractures as a result of cement failure under stress, for instance due to high injection pressures and/or temperature changes or cycles (Ravi et al., 2002a, Shen and Pye, 1989). These processes could enhance the widening of existing or developing pathways through the cement or rock (Dusseault et al., 2000).

4.4.1 Reservoir decompaction

As the pore fluid pressure decreases during production and depletion of a reservoir, the effective stress in the reservoir increases, causing elastic and inelastic compaction and

surface subsidence (Dusseault et al., 2000; Hettema et al., 2002; Settari, 2002). However, due to CO₂ injection the reservoir pressure will increase, leading to decompaction of the reservoir. Abandoned wells in prospective CO₂ storage reservoirs (especially depleted oil and gas fields) may have seen effects of preceding hydrocarbon production, depending on the timing of abandonment versus depletion. Certainly these wells have been completed and abandoned before CO₂ injection and will be exposed to expansion in the injection phase. This could affect the mechanical stability of the wellbore system.

The reservoir rock and cement possess similar mechanical properties. However, because the elasticity modulus of steel is about 15 times higher than that of cement and reservoir rock, axial deformation of the casing will be negligible relative to the cement and rock deformation. As a result of high strain incompatibility at the cement-steel interface, debonding is likely to take place under extensional loading, leading to the formation of micro-annuli at the interface.

Tensile fractures may occur in the cement when an axial extensional stress would be applied that exceeds the tensile strength of cement. As a result it is most likely that both horizontal tensile cracks and vertical cracks along the cement-rock interface occur in the cement sheath along the well in the reservoir section. The exact type of cracking depends heavily on the local geometric conditions of the cement-rock interface: a highly irregular interface implies a higher value for cement bond strength resulting in a higher probability for tensile cracking.

4.4.2 *Shear deformation*

(Re-)injection of fluids will in turn cause a decrease of the effective stress in the reservoir. In depleted reservoirs part of the strain will be recovered. These changes in stress and strain could induce shear stresses at the interface between wellbore and reservoir rock, potentially leading to failure of wellbore cement (Dusseault et al., 2000).

As a consequence of reservoir decompaction, shear strains, and possibly slip planes, tend to develop either along interfaces between rock types of different stiffness, or along existing discontinuities or planes of weakness. Particular attention therefore should be paid to the interfaces between the sealing formations and the reservoir rock. Philippacopoulos and Berndt (2000) established that 80-120 mm of lateral displacement as a result of shear stress could result in yielding of the casing.

4.4.3 *Micro-fractures and micro-annuli*

The primary cement sheath both prevents behind-casing flow of fluids as well as protects the casing from corrosion by e.g. aqueous CO₂ or brines, not only at seal levels, but also at shallow depths (Watson and Bachu, 2007). It is sensitive to flaws resulting from e.g. poor mud removal, decentralized casing (especially in deviated wells), non-optimal placement (described in Barclay et al., 2002), or cement shrinkage. Another important process resulting in damaged cement sheaths is the development of fractures as a result of cement failure under stress, for instance due to high injection pressures and/or temperature changes or cycles (Ravi et al. 2002a, Shen and Pye, 1989).

Cement failure via micro-annulus debonding and micro-fracturing of cement is commonly observed in oil and gas industry. Inadequate isolation is predominantly

associated with conductive pathways within the cement through micro fractures, or along the interfaces between cement and both casing and formation (Nelson and Guillot, 2006). Even a good cement bond log (CBL) is no guarantee for a channel-free cement sheath (Carey et al., 2007; Watson and Bachu, 2007). The presence or development of fractures or annular pathways in or along the cement dominates the permeability of the cement (Shen and Pye, 1989; Carey et al., 2007; 2008; Crow et al., 2008; Bachu and Bennion, 2008). If present, such pathways can play an important role in leakage mechanisms, significantly enhancing cement degradation (Bennaceur et al., 2004). Bachu and Bennion (2008) showed that annuli or cracks with apertures of 0.01-0.3 mm result in an increase of effective permeability of several orders of magnitude, i.e. from 1 nD for pristine cement to 0.1-1 mD of the sample with annulus or radial cracks.

4.5 Interaction of processes

Until recently, most laboratory experiments focused on the investigation of chemical degradation mechanisms and rates of individual well materials, i.e. cement and steel. Nevertheless, especially at annuli or interfaces between cement and casing or formation, the combined response of associated materials to CO₂ plays an important role. Furthermore, the analysis of chemical, mechanical and physical processes has not been iteratively coupled. The evaluation of well integrity in field cases, however, requires profound understanding of the interaction between different processes.

4.5.1 *Interaction of casing corrosion and cement degradation along micro annuli*

Recently, dedicated experimental work was performed on potential CO₂-brine flow along micro-annuli. Carey et al. (2008) executed experiments on a composite sample of cement and steel exposed to a CO₂-brine mixture at 40°C, 14 MPa pore pressure and 28 MPa confining pressure. Rather than significant mass loss of the steel, the results showed scaling on the steel surface formed due to the precipitation of siderite (FeCO₃). This required a high supersaturation of FeCO₃. The precipitation rate is controlled by temperature and pH. It could not be established if the scales accounted for any protection of the casing steel. However, the cement showed no loss of mass and the degradation was restricted to alteration of the cement until depths of 50-250 µm after 394 hours of exposure. Penetration is consistent with 1-D diffusion of CO₂ from the fluid into the cement, showing a fairly low diffusion coefficient based on the maximum observed penetration depth (Table 4.1; Carey et al., 2008). Based on the apparent sensitivity of casing to corrosion in a composite sample, Carey et al. (2008) suggest applying relatively simple corrosion logging techniques as an indicator of flow of corrosive CO₂ along the casing-cement interface.

4.5.2 *Interaction of chemical, mechanical and physical processes*

The presence of water or wet supercritical CO₂ has a high impact on the mechanical strength of cement, significantly reducing its strength. However the observed difference between effects of water and wet supercritical CO₂ is limited (Liteanu et al., 2008). As mentioned above, under certain conditions healing of fractures or annuli could occur by precipitation of for instance calcium or iron carbonates. This was observed to an extent e.g. in field samples from SACROC (Carey et al., 2007). Huerta et al. (2008) performed an experimental study to evaluate the effects of cement degradation along conduits and confining pressures on leakage rates. They show that acid attack did not substantially change the relationship between fracture aperture and confining stress for one of the samples, due to limited reactivity. However, another sample showed significant

alteration of the sample's mechanical properties during acid treatment. Mechanical weakening results in a considerable more rapid closure of the fracture with increasing confining stress, showing that leakage pathways could heal under influence of CO₂-rich fluids at decreasing fluid pressures (Huerta et al., 2008). Experiments by Lécolier et al. (2008) confirm self-healing behaviour at the cement-casing interface based on one month of exposure to a CO₂-saturated brine at 80°C and 7 MPa. During the experiment the permeability of the composite sample decreased by three orders of magnitude showing continuously decreasing flow rates. This effect is attributed to the formation and precipitation of carbonation products (Lécolier et al., 2008).

From the above it is evident that the evaluation of coupled processes and interacting materials is crucial for understanding of the long-term behaviour of the well system. While studies are increasing their focus on these fields, research directed at the integral behaviour of the system under influence of CO₂ will remain imperative.

5 Well abandonment regulations

5.1 Introduction

Many CCS projects are likely to encounter existing abandoned oil and gas wells. In order to safely store CO₂ in geological formations, it is of high importance to know the condition of these wells. However, often information on the current status of the abandoned wells is difficult to obtain. The condition of abandoned wells is primarily determined by the practiced abandonment measures. Therefore, the requirements governing the decommissioning of oil and gas wells principally determine their suitability for use in second life applications.

Worldwide, countries and/or states employ specific policies and procedures for well abandonment. This chapter presents an overview of official regulations concerning well abandonment for a selected number of countries and states (Table 5.1). The selection of countries included is based on two main criteria and therefore not exhaustive. First of all, the countries and regions considered in the current assessment are either significantly engaged in oil and gas production or involved in CO₂ storage applications. Secondly, accessibility of regulatory data was taken into account. The fact that in many cases the official regulations concerning well abandonment are only available in the official language of the country further hampered incorporation of these regulations.

Table 5.1 Regulations of countries/international regulations reviewed.

Country	State	Regulation
Denmark		A Guide to Hydrocarbon Licences in Denmark
France		Article 49 (part of Decree no. 2000-278 (RGIE, 2000))
Germany		
Norway		NORSOK Standard D-010
The Netherlands		the Mining Legislation and of the Working Conditions Regulation
United Kingdom		Guidelines for the Suspension and Abandonment of Wells by UKOOA
Australia	Western Australia	Schedule of Onshore Petroleum Exploration and Production Requirements - 1991
	Queensland	Petroleum and Gas (Production and Safety) Regulations 2004
Canada	Alberta	The Well Abandonment Guide described in Directive 20 of the Energy Resources Conservation Board
China		Control Rules on offshore Oil Well Abandonment Operations of the People's Republic of China
Japan		Well abandonment regulations by the Japanese Ministry of Economy, Trade and Industry
United States of America		US EPA Regulations on Plugging and Abandoning Injection Wells for Class II wells. API guidance
	Alaska	The Alaska Administrative Code
	California	Section 1723 from the California Code of Regulations
	Texas	Rule 3.14 from the Texas Administrative Code
International Conventions		London Convention 1972 and 1996 Protocol OSPAR Convention

The evaluation of assets for potential application in CO₂ storage projects requires a detailed, site-specific approach. The information presented in this chapter gives a general overview and will not suffice drawing conclusions on the status of specific wells. In addition, it must be noted that only standard well abandonment regulations were studied, instead of specific CCS well abandonment regulations. Although an effort was made to describe historical developments in abandonment regulations, the majority of information in this chapter comprises current or recent regulatory descriptions. Furthermore, the evaluation of regulations in this chapter focuses on prescriptive requirements. If in force, complementary regulations on e.g. labour conditions and environmental impact can significantly influence the effective management of well abandonment. However, regulations concerning these subjects as well as regarding administrative tasks, such as abandonment reporting, are beyond the scope of this study.

No legal rights can be derived from the regulatory descriptions in this chapter, as they often involve unofficial representations and/or translations of the original documents. The meaning of terms used in the different documents may differ and it is advised to consult the original documents in case clarity is required. Authentic regulations are published by the legal authorities. Several involved authorities responded to our request to approve the information in this chapter.

5.2 Denmark

5.2.1 Introduction

Oil and gas exploration started in Denmark in 1935. In 1966, hydrocarbons were discovered in the Danish part of the North Sea. After that, the exploration continued and a series of oil and gas fields were found. The first oil was produced from the Dan field in 1972.

The Danish Energy Authority (DEA) [1] is an institution under the Ministry of Transport and Energy and was established by law in 1976. It is the responsibility of the DEA to follow and evaluate the Danish and international progress in the fields of energy production, supply and research. The DEA administrates and supervises energy legislation for power and heating supply, renewable energy, and exploration for and production of oil and natural gas according to the Danish Subsoil Act. The Subsoil Act lays down the basic framework for petroleum exploration and recovery. The Act is formulated as a 'general terms act' allowing for adaptations and more detailed regulations. It regulates exploitation and recovery activities in the Danish subsoil and the Danish Continental Shelf concerning minerals, and specifically hydrocarbons.

Apart from the DEA functions in the oil and gas sector, the activities of the licensees are subject to approval from other Danish authorities. Especially the environmental regulations and the approval procedures for oil spill contingency plans should be considered.

In 2007, the DEA published "A Guide to Hydrocarbon Licences in Denmark" (DEA, 2007). This guide⁷ contains the section "Guidelines for Drilling - Exploration" which

⁷ DISCLAIMER: The English version of this document is an unofficial translation. In case of discrepancy, the original Danish text shall prevail.

was published in 1988 and revised in 2005. These guidelines apply to approval and supervision, which in consequence of the Danish Subsoil Act have been delegated to the DEA. The guidelines relate to exploration and appraisal wells for hydrocarbons and other minerals, offshore and on land as specified in Section I of the Subsoil Act. In addition, the section “Guidelines for Drilling – Exploration” provides guidelines for well abandonment. These guidelines are available in Appendix A.

5.2.2 *Well abandonment regulations*

An exploration well shall be abandoned permanently when drilling operations as well as relevant logging and test production have been carried out. However, under special circumstances the DEA may permit a well to be abandoned temporarily without permanent plugging. A well shall be plugged such that it is ensured that no fluid of flow through the hole and no communication from down hole formation to the seabed/surface via any casing annulus is possible. To this end, multiple plugs shall be placed. The total weight of the cement plugs in the well and the weight of the fluid between the plugs shall ensure that as a minimum the system is in balance with any pressure which may develop in the borehole.

In cases where the well is uncased opposite permeable zones, plugs are normally placed at least 50 m below and above the individual zones. Where there is an open hole below the deepest casing, a cement plug shall be placed in such a manner that it extends at least 50 m above and below the casing shoe. Alternatively, a mechanical plug may be positioned in the casing, within 50 m from the shoe. In addition, a cement plug, at least 50 m long shall be placed on top of this plug. Perforated intervals shall be isolated with cement plugs through the individual perforated zones and with 50 m long cement plugs below the lowermost perforation and above the uppermost perforation. Alternatively the perforated zones can be isolated by a combination of a mechanical plug and squeeze cementing of the perforations and cement plugging above the mechanical plug. In the innermost casing a cement plug must be placed from the shoe depth of the previous casing and 100 m up. A cement plug, at least 100 m long, shall be placed near the surface.

In general, plugs shall be pressure tested for sufficient time and with enough differential pressure to detect a possible leak or mechanical failure of the plug. In addition, the top of cement plugs shall be located by load testing.

5.2.3 *Additional note*

The “Guidelines for Drilling” (DEA, 2007) were defined in 1988, whereas the first oil was produced in 1972. This raises the question what happened to the wells that were abandoned before 1988. According to DEA⁸, the policy has always been the same and all individual well abandonments are approved by them. Secondly, it was noted that only two closed wells in Denmark have been leaking since 1980. Small leaks in abandoned offshore wells will, however, never be found, since these wells are generally not in the vicinity of existing platforms and are not monitored.

⁸ Communication with DEA in February 2009.

5.3 France

5.3.1 Introduction

Well abandonment regulations in France are defined by the Ministry of Economics, Industry and Employment (formerly the Ministry of Economics, Financial Affairs and Industry) in the 'Règlement Général des Industries extractives' (RGIE, i.e. General Regulations for the Extractive Industry). Within this regulation multiple decrees have been defined. In 1986, Decree no. 86-287 (RGIE, 1986) was defined for offshore drilling activities. In 2000, this decree was revised into Decree no. 2000-278 (RGIE, 2000). Within this decree, Article 49 'Fermeture définitive du puits' (translated: "Definitive closure of wells") was defined, focusing on both onshore and offshore well abandonment.

This section presents an overview of the regulations from Article 49⁹. Detailed information can be found in Appendix B.

5.3.2 Well abandonment regulations

The required closure program in France depends on the age and the state of the wells. In addition, the knowledge of the operator on the status of primary cementing and casing is taken into account. If the state of the cementing is not adequately recorded, the closure shall be preceded by an investigation of the cement and casing. In case no cementing is present, or if the cementing is not sufficiently long or has reduced efficiency, it is necessary to place, extend or improve the cementing. The latter can be accomplished by for example, circulation of cement or resin after perforation. In addition, the current pressure in the annuli needs to be determined.

In general, in Article 49 it is stated that all necessary precautions must be taken to isolate reservoirs from each other. The abandonment operations must be performed such that the permeable layers will remain permeable and that no mixing of fluid between different permeable layers shall occur. To separate permeable layers, only materials are allowed to be used that do not degrade over time. The plugs shall be placed such that either two subsequent permeable layers are isolated, or other levels are isolated, if uncontrollable flows between intermediate layers are acceptable. Plug lengths shall be at least 50 or 100 m, depending on the characteristics of the well bore.

5.3.3 General comments

In general, the plugs consist of cement, but sediments or resin are also allowed. The material that is used depends on the location of the plug. Only materials with known characteristics, such as resistance and plasticity, shall be used. The quality of isolation must be checked by means of a load test and a pressure test. The height and quality of the cement can be monitored by a Cement Bond Log (CBL).

⁹ DISCLAIMER: The English version of this document is an unofficial translation. In case of discrepancy, the original French text shall prevail.

5.4 Germany

5.4.1 Introduction

Germany has a long history for mining regulation, in particular concerning the right to explore and produce minerals. The first known legal basis dates back to the year 1158. In 1865 a new mining law was approved which concerned a central regulation. After the Second World War the existing jurisdiction concerning mineral resources was decentralised to the eleven states in the Western part of Germany. The Eastern part of Germany was directed to the government in Berlin and until 1947 only state companies received the right to explore and produce [4].

5.4.2 Well abandonment regulation

The first abandonment policies were established as ‘Bergpolizeiliche Vorschriften’ (Mining police orders) in the 19th century for each German state separate; Prussia, Saxony, Oldenburg, Schaumburg-Lippe etc. Until recently a complex regional history of regulations was in place. Currently the German exploration and production of hydrocarbons is regulated under the ‘Bundesberggesetz BBergG’ (Federal mining law) dated 13 August 1980, and the ‘UVP-VBergbau’ (ordinance on the environmental impact assessment of mining projects) dated 13 July 1990, as well as the respective mining regulations of the various states. In addition, the ‘Verein Deutscher Ingenieure’ (Association of German Engineers) has issued a number of guidelines dealing primarily with the relevant mechanical equipment [5].

The Federal Institute for Geosciences and Natural Resources (BGR) in Hannover is currently documenting the well abandonment regulation per state in Germany. This report will be publicly available in the second half of 2009¹⁰.

5.5 Norway

5.5.1 Introduction

As a result of the enforcement of the Continental Shelf Act in 1963 the first production license in Norway was granted by State in 1965, followed by the first production well drilled in 1966. The Norwegian petroleum production started after the discovery of the Ekofisk reservoir in 1969 which was the first commercially viable discovery. After the start of production on 15 June 1971 more discoveries were made in the Norwegian continental shelf. At the beginning of 2008, 57 new oil and gas fields were in production in Norway (Ministry of Petroleum and Energy, 2008), (Bull, 1981). The total number of non-active and active development, exploration, production and injection wells on the Norwegian Continental Shelf per 1 January 2006 can be found in Vignes et al. (2006), as well as ages of the wells.

¹⁰ Personal communication with BGR.

5.5.2 *Exploration and operation phase*

On 1 July 1985 the 1963 Continental Shelf Act was replaced by the Norwegian Petroleum Act containing requirements for preparing a field specific environmental impact assessment (EIA) for the exploration and operation phase of petroleum activities in the Norwegian shelf. However, the first Norwegian EIAs were criticised for focussing too little on field development concepts and the technical design of the installations (Kinn, 1981). The 1985 Petroleum Act was revised in 1997 in which a legal basis was established for requiring Regional EIAs (REIA). With REIAs the total planned and expected activity and its effects within an area are evaluated.

Norway participates in the establishment of international standards, ISO and EN, which form the basis of petroleum activity. To ensure continuance in the Norwegian safety framework and climate conditions amendments are required. Therefore, in 1993 NORSOK standards were established by the Norwegian petroleum industry to ensure adequate safety, value adding and cost effectiveness for petroleum industry developments and operations [5].

5.5.3 *Well abandonment regulation*

Decommissioning activities in Norway are regulated under the 1996 Petroleum Act as well as under the obligations of the OSPAR Convention (Convention for the Protection of the Marine Environment of the North-East Atlantic). The Petroleum Act requires licensees to submit a decommissioning plan to the Ministry of Petroleum and Energy two to five years prior the expiring or surrender of a license or the termination of a facility. The decommissioning plan must consist of two main parts; a disposal plan and an impact assessment. OSPAR Decision 98/3, which came into force on 9 February 1999, concerns rules on the disposal of offshore installations at sea (NPD, 2008), (Ministry of Petroleum and Energy, 2008). See for more information on these regulations the OSPAR Convention description in Section 5.13.2.

Specific abandonment regulations are developed in NORSOK Standard D-010 (Standards Norway, 2004) which focuses on well integrity. The standard was amended in 2004 in order to account for technological development including CO₂ storage. The standard defines the minimum functional and performance oriented requirements and guidelines for well design, planning and execution of safe well operations in Norway. A detailed description of relevant guidelines concerning well abandonment is available in Appendix C. In the remainder of this section a brief description of the standard is presented. In addition, a number of discussion points concerning the NORSOK Standard D-010 in relation to CO₂ applications is presented.

5.5.4 *General well abandonment regulations*

In general, permanently plugged wells shall be abandoned with an eternal perspective. There shall be at least one well barrier between surface and a potential source of inflow, unless it is a reservoir that contains hydrocarbons and/or has a flow potential where two well barriers are required.

Plug lengths of 100 m are required. It must extend, at a minimum, 50 m above a source of outflow or leakage point. A plug in transition from open hole to casing should extend

at least 50 m below the casing shoe. If the plug is set inside the casing and with a mechanical plug as a foundation, the minimum length must be 50 m.

The plug installation shall be verified through documentation of job performances. In addition, the position of the plugs shall be verified by either tagging or pressure tests. If a mechanical plug is placed, only this plug shall be tested. The cement plug on top of the mechanical plug does not have to be verified.

5.5.5 Discussion points

In a report prepared by SINTEF (Randhol et al., 2007), some topics in the NORSOK D-010 standard are criticised in relation to CO₂ applications. In addition, more stringent requirements are needed in some areas for the application on CO₂ wells:

- *material selection of barriers for abandoned wells*: the requirements for material are too general and specific details are not provided, e.g. type of steel, cement.
- *well barrier in several stages*: no cement plug is placed in the caprock which is insufficient for wells exposed to CO₂.
- *completion string*: according to NORSOK the tubing can be left in place in case of permanent abandonment which is inadequate for CO₂ applications.
- *temporary well abandonment*: is not regulated to a certain time frame.
- *monitoring permanently abandoned wells*: guidelines are missing

5.6 The Netherlands

5.6.1 Introduction

In the Netherlands the regulations and guidelines for mining activities date back to the Napoleonic times of 1810 ('Loi des Mines'). These regulations were mainly aimed at natural resources mined in quarries and coal mines. Only in the 20th century wells were drilled to explore for hydrocarbons. The first commercial oil was found in 1943 (Schoonebeek) and first gas was struck in 1948 (Coevorden). In 1959 the giant Groningen gas field was discovered (ca. 2800 billion cubic meters) which led to a sharp increase of drilling activity, both onshore and offshore. Eventually this led to new regulations in 1964 to cope with the new situation. These regulations consisted of the Mining regulations ('Mijnregelement 1964') and the Mining Regulations Continental Shelf ('Mijnregelement Continentaal Plat') which came into force in 1967 (no offshore wells were drilled prior to this date). In 2003 these regulations were updated and united by a new updated Mining act. The regulations and guidelines concerning well abandonment there were not changed since 1964. Before that time well abandonment was not explicitly dealt with.

In the Netherlands there are some 1140 wells drilled before the Mining act was updated in 1964 and 1967. For these wells no general regulations on well abandonment were in place. Therefore, more specific investigations will have to be executed to determine their appropriateness for future applications such as geological storage of CO₂.

5.6.2 Regulatory instruments of well abandonment

Regulatory instruments involved in the evaluation of abandonment programmes are laid down in the prescriptive legislation of the Dutch Mining Regulations, as well as in the goal-setting legislation of the Dutch Mining Decree and the Working Conditions

legislation. The wells and boreholes section in the Mining Regulations dictates prescriptive rules on abandonment measures. The Mining Decree includes general and fit for purpose requirements to the construction, intervention and abandonment of boreholes and wells to prevent damage to health, safety and environment (HSE) interests. Compliance to these goal-setting elements of the Mining Decree is generally demonstrated by using best practices and state-of-the-art techniques in order to reach an acceptable risk level. In addition, the Mining Decree is coupled to the Working Conditions Act, including a Safety Case regime that requires a justification of risks to workers on a mining location or installation, in each step of its lifetime, to be acceptable. This also accounts for activities like construction, intervention and abandonment of wells that are carried out on these mining works. The coupling of the Mining Decree to the Working Conditions legislation provides an extra requirement to prevent adverse effects on HSE. As a result the Safety Case extends beyond the Mining Regulations by including the external risks that are projected from the mining location or installation to surrounding HSE interests. The integral legislation framework associated with Mining is enforced by the State Supervision of Mines under the Dutch Ministry of Economic Affairs.

5.6.3 *Dutch Mining Act*

Dutch Mining Act consists in fact of three levels: the 'Mijnbouwwet' (Mining Act itself), the 'Mijnbouwbesluit' (Mining Decree) and the 'Mijnbouwregeling' (Mining Regulations). The current Mining Act, accepted at October 12, 2002 and installed at January 1, 2003, contains rules in relation to the exploration and development of mineral resources and in relation to mining activities. It aims to give a clear framework for responsible and effective mining. The Mining Decree specifies the main elements of the Mining Act. More technical details of the whole Mining Act system are set forth in the Mining Regulations.

5.6.3.1 *Mining Regulations*

Chapter 8 of the Mining Regulation deals with boreholes and wells. Sections 8.1 – 8.4 deal respectively with general issues, working program and reporting, construction of boreholes and reparation of wells, and equipment of wells. Section 8.5 deals with abandonment of boreholes and wells.

Besides well plugs, the presence of a primary cement sheath outside of the casing is an important issue, since gases can migrate relatively easily when a well is uncemented at the level of a gas-bearing zone. Dutch Mining Regulation Chapter 8 gives extensive regulations for the placement of cement plugs when abandoning wells and for uphold safety requirements and installations, but pays little technical attention to down hole primary well cementing. This is regulated on the goal setting Mining Decree level. Without any further description Section 8.2.1 demands a working programme describing the cementing per casing interval (8.2.1.1.e). A good primary well cementing job is in fact secured by the required monitoring of casing pressures in Section 8.4.4. This system leaves in fact the freedom to the operator to adjust the primary cementing to the specific prevailing field conditions. Operators have extensive internal regulations and guidelines for primary well cementing.

Concerning the regulations on cement jobs when setting the casings intervals or and setting cement plugs while abandoning the well as stated in the current Mining Regulations have not been amended in the latest version. This implies that they are

equal to those in the previous Mining Regulations Continental Shelf and the Mining Regulations 1964. Detailed information can be found in Appendix D.1.

5.6.4 *Working Conditions Act*

The purpose of the Working Conditions Act is to have equivalent and safe working conditions in all companies in the Netherlands, regardless of the number of employees. Employers are primarily responsible for the working conditions in their company. And employers and employees cooperate on improving the working conditions. The health and safety service can advise in this. The Health and Safety Inspectorate supervises employers' compliance with the Working Conditions Act.

The Working Conditions Act describes the main features for health and safety policy. The general rules of the Working Conditions Act are elaborated upon in the Working Conditions Decree and the Working Conditions Regulation. The Working Conditions Decree contains concrete provisions which employers must follow, classified by subject. A number of subjects in the Working Conditions Decree have been elaborated upon in the Working Conditions Regulation. Detailed information can be found in Appendix D.2.

5.6.4.1 *Safety cases*

The requirement for the mining industry to produce and submit a safety and health document (safety case) emanated from the Piper Alpha disaster. Following publication of Lord Cullen's report of the Public Inquiry into the Piper Alpha disaster, Government stated its commitment to implement those recommendations of relevance to mining activities in The Netherlands.

The safety case regime is laid down in the Working Conditions legislation and requires companies to follow a logical structured approach, when undertaking an objective critical review of their installations, locations, facilities or units and the operations and activities performed therein, including in wells. It identifies four key elements considered essential in the work performed by companies in compiling a safety and health document. This work provides the degree of assurance necessary to satisfy Company management, their workforce and finally, to demonstrate to Government, that operational activities can be performed safely, with due regard to the protection of human life. These elements are:

- risk identification;
- risk evaluation;
- risk elimination and reduction;
- risk control and management.

The primary objective of the safety case process is, to ensure that the safety and health protection of all personnel involved in mining operations and associated activities, is safeguarded. This requires the implementation of measures necessary to ensure:

- that the design, use and maintenance of mining installations, locations, facilities, units and of the equipment and systems therein, whether fixed, mobile, portable or for individual use, are safe and remain in good condition;
- that the risks incurred by personnel at their place of work, both operational and occupational, have been identified and evaluated;

- that adequate measures exist or will be taken to ensure that workplaces are and will be maintained safe and that risks to personnel have been eliminated, or reduced to a level that is “As Low As is Reasonably Practicable” (ALARP);
- that improvements to the existing situation, resulting from advances in technology and technical knowledge will be adopted.

5.7 United Kingdom

5.7.1 Introduction

The first oil and gas legislation was established in 1918 when the Petroleum (Production) Act was enacted. The Crown now had the right to control exploration and production in the UK and to grant licences. The 1918 act was revoked by the introduction of the Petroleum (Production) Act in 1934. The Petroleum (Production) Act 1934 and elements from the Continental Shelf Act 1964 was consolidated into the Petroleum Act 1998. This act contains, among others, rules relating to decommissioning of offshore installations [7].

5.7.2 Abandonment of wells

5.7.2.1 Onshore well abandonment

Decommissioning of onshore wells and associated hydrocarbon installations will be addressed through IPPC legislation. Permission to decommission onshore wells is also required from the Department of Trade & Industry under The Petroleum (Production) (Landward Areas) Regulations 1995.

5.7.2.2 Offshore well abandonment

Abandonment of offshore wells has to be carried out in accordance with the Oil & Gas UK Guidelines for the Suspension and Abandonment of Wells developed by the UK Offshore Operations Association (UKOOA). The full text of this guideline (UKOOA, 1995) can be found in Appendix E.

5.7.2.3 Description of the UKOOA (1995) guideline

The required standards for well abandonment involve an acceptable permanent barrier (the main characteristics of abandonment materials (plugging material)), the location of the permanent barrier for isolation from the surface, minimum requirements for permanent barriers and a verification procedure.

The barrier requirements involve the main characteristics of abandonment material, e.g. low permeability, long term integrity, no shrinking. The cement plug must be a column of at least 100 ft depth made out of good cement. Where possible 500 ftAHD plugs must be used. The guidelines distinguish between a cased hole plug and an open hole plug, as well as cemented casing and alternative plugging material. Two permanent barriers from surface/seabed are required by these guidelines to achieve effective isolation of hydrocarbon bearing permeable zones. The first barrier should extend at least 100 ft above the highest point of potential inflow, the second barrier acts as a backup of the first barrier.

The minimum requirements for permanent barriers are set per specific circumstances; open hole, casing shoe, perforated casing, behind casing and casing cuts and liner caps.

According to the guidelines it is important that the position and effectiveness of barriers can be confirmed. The guidelines do not outline specific requirements for verification. They do, however, recommend minimum requirements in case of open hole (weight tested), cased hole (first barrier: tagged and pressure tested, second barrier: tagged), annulus, casing cuts and liner laps (log).

When the isolations are achieved the removal of downhole equipment is not required. Typically, well conductor and casing strings are cut 3-5m below the mudline, and conductors, casings and wellhead are withdrawn (O'Connor et al., 2004).

5.8 Australia

5.8.1 Introduction

By the end of the 19th century and the beginning of the 20th the first wells were drilled in Australia. These wells were mostly for the purpose of water extraction, however also oil substances and gas were found. Australia's first oil field was discovered in 1924, as a result of an attempt to drill for water [8]. In 1923 the Petroleum Act was implemented which covered petroleum (oil and gas) exploration and transmission (Petroleum and Gas Inspectorate, 2005).

Western Australia has been producing crude oil since 1967 and condensate since 1972. The first discovery of oil in the State was at Rough Range in 1953, but this field was too small for commercial development. The State's first commercial field, on Barrow Island, began operations in 1967. The first commercial quantities of natural gas in the onshore Perth Basin were produced from Dongara in 1971 and Mondarra in 1972. Offshore exploration began on the North West Shelf in 1967. Although the search was initially for oil, there were shows of gas as early as 1968. Major discoveries of gas were made at North Rankin, Goodwyn and Scott Reef in 1971 and have continued up to the present day.

5.8.2 Well abandonment regulations

In the second half of 1950 abandonment of wells was first taken up in the Petroleum Act of 1923 which was updated in 1955 and 1958. A new subdivision of the Petroleum Act of 1923 was made in 1962, including the amendments until then. The last amendment was in the year 2000 (The Office of the Queensland Parliamentary Counsel, 2008).

In Western Australia, onshore well abandonment has since 1991 been provided for in the *Schedule of Onshore petroleum Exploration and Production Requirements - 1991*. This Schedule is served on petroleum titleholders in lieu of regulations.

5.8.2.1 Offshore wells

The main operations concerning petroleum exploration and production in Australia is situated offshore. About 96 per cent of oil and 83 per cent of gas is produced from offshore sources (Australian Government, 2008).

Since 2005 NOPSA (National Offshore Petroleum Safety Authority, a Statutory Agency regulating Commonwealth, State and Territory coastal waters with accountability to the

relevant Ministers) administers offshore petroleum safety regulations in order to regulate the Australian offshore petroleum industry and assist it to reduce the health and safety risks to an acceptable level. For offshore petroleum operations currently the Offshore Petroleum Act 2006 (Offshore Petroleum and Greenhouse Gas Storage Act 2006) provides the legislative background as well as the Environment Protection (Sea Dumping) Act 1981 [10]. Approval of decommissioning is based on international protocols and treaties as set out in the Guidelines for the Decommissioning of Offshore Petroleum Facilities. In practice, extensive experience of such upstream petroleum decommissioning is probably not yet available in Australia (Australian Government, 2008).

Each State and Northern Territory has made or will make corresponding amendments to existing legislation, so as to create an equivalent occupational health and safety regime for petroleum activities in State and Northern Territory coastal waters.

5.8.2.2 *Onshore wells*

Onshore oil and gas projects involving more than one jurisdiction, due to individual state based legislation. Especially, Western Australia and Queensland established a comprehensive basis of legislation for onshore well abandonment. These two examples of state legislation in Australia are presented in the following sections.

5.8.3 *Western Australia*

Western Australia has a petroleum legislation that is common to both its onshore and offshore areas. The legislation is similar to the national Offshore Petroleum Act 2006. Requirements for onshore petroleum exploration and production were established in 1991, in which decommissioning of onshore wells in the state is regulated. The requirements which are set for well abandonment and plugging can be found in Appendix F.1.

5.8.4 *Queensland*

In Queensland the abandonment of offshore wells is regulated according to the NOPSA requirements. In case of onshore wells, Queensland established requirements for abandonment in the Petroleum and Gas (Production and Safety) Act 2004 and in the Petroleum and Gas (Production and Safety) Regulations 2004. An overview of relevant issues concerning onshore well abandonment in the regulations can be found in Appendix F.2. In this appendix, the requirements for plugging and abandoning petroleum wells and bores are described in 'Schedule 3'. Specific requirements for plugging and abandonment are not set in the regulations.

5.9 **Alberta, Canada**

5.9.1 *Introduction*

Every province in Canada (Figure 5.1) has specific policies and procedures for well abandonment procedures. For this study, only the Alberta Basin is considered. From 1947 on, this field has been exploited.

Effective January 1, 2008, the Alberta Energy and Utilities Board (EUB) has been realigned into two separate regulatory bodies. Firstly, the Alberta Utilities Commission (AUC) has been installed, which regulates the utilities industry. Secondly, the Energy

Resources Conservation Board (ERCB) has been installed, which regulates the energy industry. The ERCB is an independent, quasi-judicial agency of the Government of Alberta [14]. This board has formulated several directives concerning the oil exploration and exploitation activities in the Alberta Basin. The Well Abandonment Guide is described in Directive 20. This latest revised release of the directive was in December 2007 (ERCB, 2007). Amendments to this directive have been made in Directive 72 (ERCB, 2008) and will be incorporated in a future release of Directive 20.

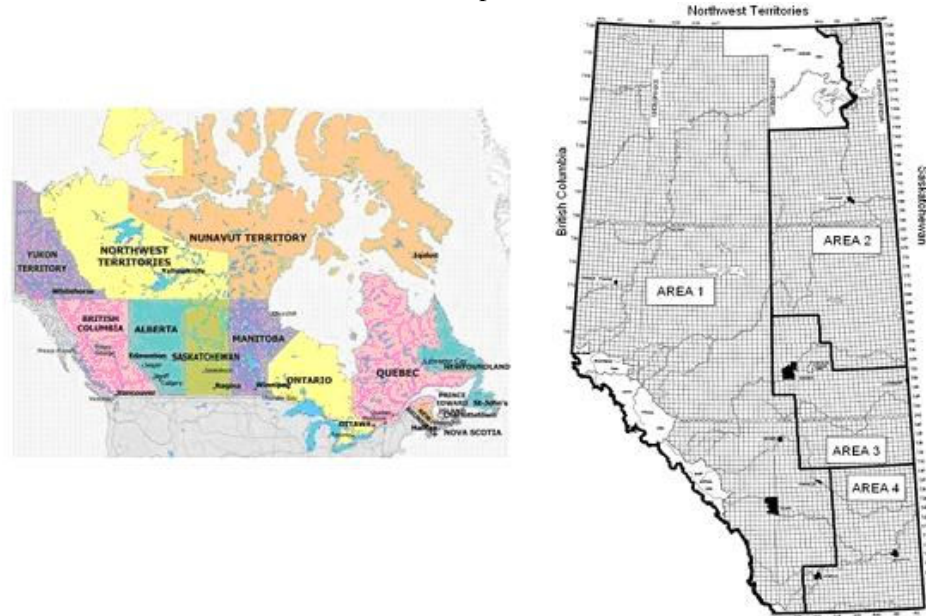

Figure 5.1 Left: Canada, with Alberta [15]. Right: Four Program Areas in Alberta, adapted from ERCB (2007).

5.9.2 Well abandonment process

The information in the remaining part of this section has been summarized from ERCB (2007), unless stated otherwise.

The objective of a well abandonment is to cover all nonsaline groundwater and to isolate or cover all porous zones. A difference is made between open-hole abandonment requirements and cased-hole abandonment requirements. An overview of the requirements for both types is provided in the next sections. The last section deals with surface abandonment.

5.9.3 Open-hole abandonment requirements

The abandonment program for an open-hole well depends on the location of the well within the province and whether the well is in an oil sands area. For open-hole abandonments, the province Alberta is subdivided into four program areas (Figure 5.1): Western Alberta (Program Area 1), Northeastern Alberta (Program Area 2), East Central Alberta (Program Area 3) and Southeastern Alberta (Program Area 4). Designated oil sands areas exist in Program Areas 1 and 2.

The geology of Program Area 1 is too diverse to support a single plugging program. Therefore, licensees of wells in this region must develop their own plugging program that meets the requirements of Directive 20. For the remaining three Program Areas, prescribed plugging programs have been developed by the EUB (now ERCB).

In general, cement plugs must be placed that are of sufficient length and number to ensure that crossflow between porous zones does not occur. Secondly, plugging programs must cover all nonsaline groundwater by cement, and must isolate or cover all porous zones. The general and Program Area specific requirements are presented Appendix G.1.

5.9.4 *Cased-hole abandonment requirements*

The abandonment program for a cased-hole well depends on the location of the well, if the well was completed, and whether the well penetrated any oil sands zones. In a cased-hole abandonment, the licensee must abandon each completed pool separately and must cover all nonsaline groundwater with cement. If the casing strings in a cased-hole well were not cemented according to the requirements in Directive 009 (ERCB, 1990) the cement location and condition must be evaluated.

Different abandonment requirements have been defined for wells that do and do not penetrate oil sands zones. An overview is given in Appendix G.2.

5.9.5 *Additional requirements*

Appendix G.3 presents additional requirements concerning removing casings and setting cement plugs.

5.10 **China**

At the end of the 1950s China's offshore oil industry started in the South China Sea. After 1965 the exploration focus was repositioned to the Bohai Bay in the North of China. Until the year 1972 simple technology was used for discovery wells for oil and gas. From 1966 to 1972 in total four fixed drilling platforms were built, 14 wells were drilled and three oil-bearing structures were discovered in Bohai Bay. In this period experience was built up for offshore oil exploration. After 1973 the development equipment began to be renewed, and a supply of jack-up vessels, three-purpose (towing, weighing anchor and casting anchor, supply) workboats, geophysical survey vessels were built at home and introduced from abroad for conducting exploration and development tests in Bohai Bay.

On 30 January 1982 the Chinese State Council promulgated Regulations of the People's Republic of China concerning the Exploitation of Offshore Petroleum Resources in Cooperation with Overseas Partners and decided to establish China National Offshore Oil Corporation (CNOOC). CNOOC has the exclusive right of conducting oil exploration, development, production and selling and taking charge of the business on exploiting offshore oil resources in the country's sea areas, possibly in cooperation with overseas partners [16].

5.10.1 *Onshore well abandonment regulations*

Information on onshore regulations in China appeared to be difficult to obtain.

5.10.2 *Offshore well abandonment regulations*

CNOOC established the Control Rules on offshore Oil Well Abandonment Operations. In Appendix H the English translation of the regulations can be found. The main focus of the text is on the technical requirements for well abandonment operations, in which among other topics conditions of well abandonment operations, permanent well abandonment and temporary well abandonment are addressed.

5.11 **Japan**

The Japanese Ministry of Economy, Trade and Industry (METI) [18] specifies the provision and the standards for the necessary measures of an abandoned oil well. The standard of abandoned oil wells is specified in 1986 and is based on the Mine Safety Act¹¹. METI provided the Japanese regulations on well abandonment in Japanese (METI, 1986).

The Japanese authorities distinguish two different cases for abandonment. First of all, regulations are defined for abandonment of wells for oil or natural gas production from structural reservoirs. Secondly, regulations are defined for wells producing natural gas that is dissolved in water. Appendix I contains an unofficial translation of the regulations.

5.12 **United States of America**

5.12.1 *Introduction*

Regulations regarding the abandonment procedure and requirements were first installed in the USA after 1930 and in some states even after World War II (Calvert and Smith, 1994). The initial prescriptions were significantly improved in 1952, when the American Petroleum Institute (API) presented a list of standard cement compositions and additives which divided the cement in eight classes depending on the depth of application and additives. The API classification is still being used for specification of the composition of wellbore plugging cements used at specific downhole conditions. Since 1953 developments in plugging procedures were mostly restricted to changes in plug lengths and the number of plugs applied per well (Ide et al., 2006).

The US regulations show a distinct regional nature. While the objective of plugging is the same in all states (i.e. protection of potable water aquifers and isolation of hydrocarbon zones), abandonment regulations differ from one state to another on more detailed levels (e.g. plug lengths, additives).

5.12.2 *Underground Injection Control (UIC)*

The most significant improvement with respect to the original requirements was effected by the introduction of the Safe Drinking Water Act (SDWA) in 1974 that embraced the philosophy of zonal isolation or displacement. Under this Act the Underground Injection Control (UIC) Program was established in order to enable the safe injection of fluids in subsurface reservoirs by maintaining the current and future

¹¹ Personal communication with METI, February 2009.

sources of drinking water. The UIC Program is responsible for regulation in the USA at regional level of the construction, operation, permitting, and closure of injection wells that inject fluids in underground reservoirs for storage. Adopting this approach required operators to isolate all fresh water drinking zones from hydrocarbon reservoirs by cement plugs (Ide et al., 2006) and to prevent movement of other fluids into the wellbore by applying adequate mud fluids (Englehardt and Wilson, 2001).

The UIC Program defines five classes of wells based on similarities in the fluids injected, construction, injection depth, design, and operating techniques:

- Class I:* inject industrial non-hazardous liquids, municipal wastewaters or hazardous wastes beneath the lowermost underground sources of drinking water (USDW). These wells are most often the deepest of the UIC wells and are managed under technically sophisticated construction and operation requirements.
- Class II:* inject fluids in connection with conventional oil or natural gas production, enhanced oil and gas production. Most of the injected fluid is brine.
- Class III:* inject fluids associated with the extraction of minerals or energy, including the mining of sulfur and solution mining of minerals.
- Class IV:* inject hazardous or radioactive wastes into or above USDWs. Few Class IV wells are in use today; these wells are banned unless authorized under an approved Federal or State ground water remediation project.
- Class V:* includes all injection wells that are not included in Classes I-IV. In general, Class V wells inject non-hazardous fluids into or above USDWs; however, there are some deep Class V wells that inject below USDWs. This well class includes Class V experimental technology wells including those permitted as geologic sequestration pilot projects [20].

5.12.3 *Environmental Protection Agency (EPA)*

Under the SDWA (see Section 5.12.2), the Environmental Protection Agency (EPA) sets standards for drinking water quality. In 2008 the EPA proposed a rule for the creation of a Class VI well category which would concern wells which only inject CO₂ (EOR wells remain Class II wells).

According to the US EPA, the objectives of an abandonment procedure of injection wells are to [19];

1. eliminate physical hazards;
2. prevent groundwater contamination;
3. conserve aquifer yield and hydrostatic head;
4. prevent intermixing of subsurface water.

A selection of the appropriate methods of well abandonment should be made after considering;

1. the casing material;
2. casing condition;
3. diameter of the casing;
4. quality of the original seal;
5. depth of the well;
6. well plumbness;
7. hydrogeologic setting;

8. the level of contamination and the zone or zones where contamination occurs.

If no cross-contamination can occur between various zones and contamination cannot enter from the surface, grouting the well from bottom to top without removing the casing may be sufficient. However, since the primary purpose of monitoring well abandonment is to eliminate the vertical migration of fluids along the borehole, removal of the casing is the preferred method of well abandonment. When the casing is removed, the borehole can be sealed completely and there is less potential for channelling in the annular space or inadequate casing/grout seals [19].

Regulatory requirements for well abandonment vary depending on the class wells as well as the state. Each state can choose on the enforcement of EPA regulations. On state level seven states share authority with EPA [21]. In Figure 5.2 the implementation of regulation in the different U.S. states is shown.

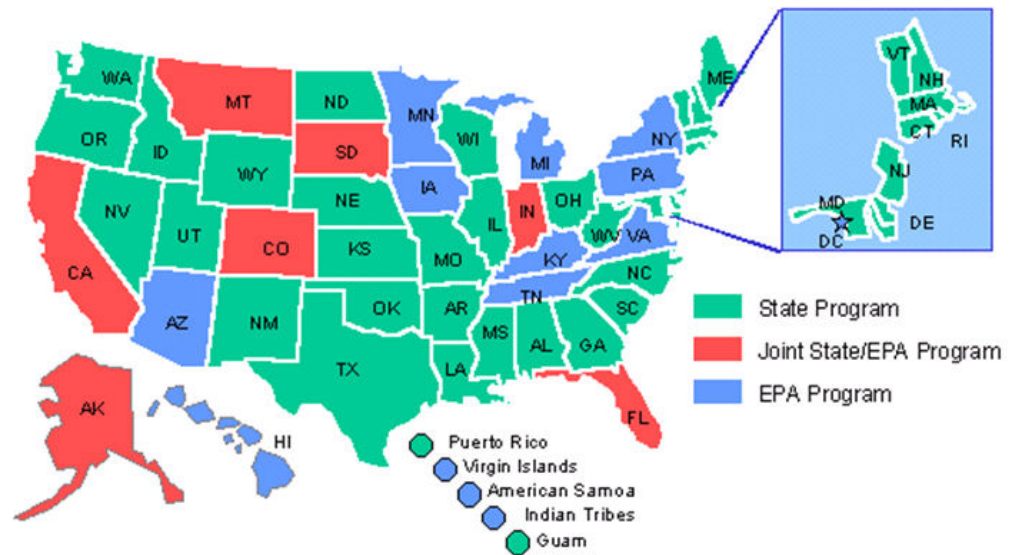

Figure 5.2 The implementation of regulation in different states of the USA. Most states are responsible for the implementation of the UIC program (green). The red coloured states implement it jointly with the EPA and in case of the blue coloured states the EPA implements the program directly [23].

In Appendix J.1 the text available from the EPA website concerning the general requirements for plugging and abandoning wells as well as for class II wells is presented.

5.12.4 American Petroleum Institute (API)¹²

The American Petroleum Institute (API) provides in its API Bulletin E3 (API, 1993) guidance on environmentally-sound abandonment practices for wellbores drilled for oil and gas exploration and production operations, primarily focused on onshore wells. API states that several safeguards utilized during well construction and during plugging operations prevent fluid migration in plugged and abandoned (P&A) wells.

¹² Reproduced courtesy of the American Petroleum Institute from API Bulletin E3

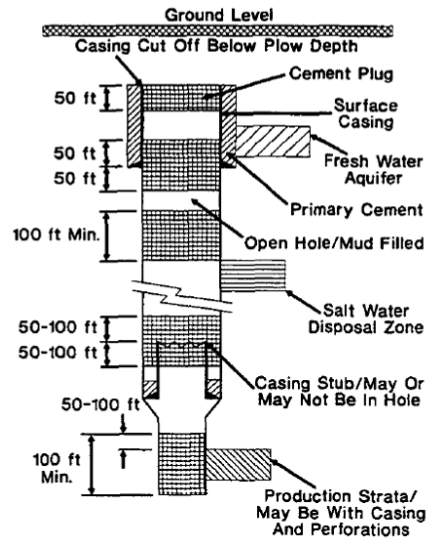

Figure 5.3 Schematic of properly plugged well (reproduced courtesy of the American Petroleum Institute)

Safeguards provided during the construction of a well include surface casing and production casing installed and adequately cemented. Cement and mechanical plugs placed at critical points in the wellbore during either prior remedial or plugging operations prevent fluid migration within the wellbore. Safeguards provided during plugging and abandonment operations include cement plugs set in open holes as well as cement or mechanical plugs set above perforated intervals in production or injection zones, at points where casing has been cut, at the base of the lowermost fresh water aquifer, across the surface casing shoe, and at the surface. Figure 5.3 shows a schematic of a typical properly plugged and abandoned well. Some US state agencies specify additional plug placements in some situations. An overview of the API guidance is presented in Appendix J.2.

5.12.5 Alaska

The first commercial oil well developed in Alaska was in the year 1902 in the Katalla Oil Field. The regulatory agency in Alaska overseeing the underground operation of the Alaska oil industry on private and public lands and water is the Alaska Oil and Gas Conservation Commission (AOGCC). It is responsible for regulating drilling and production of oil and gas. Its origin dates back to 1955 [24].

5.12.5.1 Well abandonment

In The Alaska Administrative Code, the abandonment and plugging of wells is addressed (The Alaska Administrative Code, 2009). In the Article the abandonment of wells, plugging of well branches, suspended wells, well plugging requirements, shut-in wells, well abandonment marker, water wells, onshore location clearance and offshore location clearance is addressed. The original text can be found in Appendix J.3.

5.12.5.2 Well information databases

The AOGCC also maintains an Oil and Gas Information System containing information on public well and production files and databases. The database can be found on its website [24]. Oil and gas data, well files, and digital log data can be found there.

5.12.6 *California*

In 1915, the first regulations for drilling of wells were published in California (McLaughlin, 1915). This was mainly due to the widespread demand among oil operators for regulations to prevent damaging the property of a neighbour by the infiltration of water. According to the State Mining Bureau it was not necessary to instruct the experienced operators. The regulations, therefore, were rather supporting than strictly prescribing. Section 16 of this law describes the well abandonment. It states that it is the duty of the owner of a well to prevent that water enters the oil-bearing strata.

In 1970, the California Environmental Quality Act was defined. The Division of Oil, Gas and Geothermal Resources (DOGGR) from the California Department of Conservation (DOC) implemented this act in the California Code of Regulations (DOGGR, 2006). These regulations define well abandonment regulations for both onshore and offshore wells. These regulations are presented in Appendix J.4.

5.12.7 *Texas*

The Texas Administrative Code (TAC) is a compilation of all state agency rules in Texas and was created by the Texas Legislature under the Administrative Code Act in 1977 [25]. In the Administrative Code Act, the Legislature directed the Office of the Secretary of State (SOS) to compile the TAC. Each title within the TAC represents a category. Each title is divided into multiple parts, to which related agencies are assigned. The Railroad Commission of Texas (RRC)¹³ is assigned to Part 1 of Title 16 (Economic Regulation). Chapter 3 within this part is dedicated to the Oil and Gas Division (SOS, 2007). The first version of this rule was adopted in January 1976 and the most recent amendments were adopted in January 2007.

5.12.7.1 *Well abandonment*

The rules for plugging and well abandonment are listed in Rule 3.14 (SOS, 2007). The information in this section has been compiled from this rule, unless stated otherwise.

Wells shall be plugged to insure that all formations bearing usable quality water, oil, gas or geothermal resources are protected. Plugs shall be set to isolate each productive horizon and usable quality water placing the required plug at each depth as determined by the Texas Commission on Environmental Quality or its successor agencies.

Appendix J.5 presents Rule 3.14 from the Texas Administrative Code. An important note is that cement plugs shall be placed by the circulation or squeeze method through tubing or drill pipe. Dump bailing is not permissible.

5.13 **International Conventions**

5.13.1 *London Convention 1972 and 1996 Protocol*

One of the oldest global conventions is the London Convention on the Prevention of Marine Pollution by Dumping of Wastes and Other Matter 1972 covering the North Sea

¹³ The RRC was established in 1891. Nowadays, the RRC has primary regulatory jurisdiction over oil and natural gas industry in Texas [26].

and North-East Atlantic. In 1996 the convention was amended to allow captured CO₂ to be stored into sub-seabed geological formations under certain restrictions. In 2006 the 1996 Protocol to the Convention entered into force. It is the first time that a maritime treaty governs storage of wastes in the seabed, as well as the abandonment of offshore installations. The amendment forms a basis in international law to regulate storage of CO₂ in geological reservoirs under the seabed [27]. Under certain circumstances, the Convention governs the issue of permits for the disposal of installations at sea. Specific laws for governing decommissioning are prepared and implemented by national governments.

The following is stated on well integrity in relation to CO₂ storage in the last amendment: “Particular attention should be paid to integrity of the wells. Over the longer term, the risk assessment should also address any change in the integrity of the seal and of the plugs in the abandoned wells and might include the effects of CO₂ dissolution and mineralization.” and “Special care should be taken to use sealing plugs and cement that are resistant to degradation from carbonic acid.” (London Protocol, 2006b).

5.13.2 *OSPAR Convention*

The OSPAR Convention also applies to waste disposal and other activities in geological reservoirs under the seabed. In 2007 the OSPAR Commission amended the Convention to allow for environmentally safe storage of CO₂ in the Northeast Atlantic and at the same time excluding the injection of CO₂ in the water column and the disposal onto the seabed. The OSPAR convention concerns the Northeast Atlantic and is seen as one of the most comprehensive and strict legal frameworks in place for the protection of the marine environment. The Commission of the OSPAR Convention stresses that carbon capture and storage is one option as part of a package of possible measures reducing CO₂ emissions [28]. Specific regulation for abandonment of wells is not included.

6 Risk management methodologies

Risk management comprise all activities towards the assessing, mitigating (to acceptable levels) and monitoring of risks. According to the ISO/DIS 31000 standard, the process of risk management includes the establishment of the context or assessment base, the identification of potential risks and the assessment and treatment of identified risks. Furthermore, a risk-management plan should be developed and implemented, describing risk control implementation and responsibilities (ISO, 2009).

6.1 Risk assessment

The formal definition of risk assessment is: *a systematic process for describing and quantifying the risks associated with hazardous substances, processes, action or events.* (Covello and Merkhofer, 1993) Risk assessment is the process of identifying hazards and evaluating the risk of them. It includes estimates of uncertainty and is based on the scientific knowledge available. In a profound risk assessment framework, the following questions should be answered:

- What can go wrong that may lead to any hazardous impact (scenario analysis - qualitative risk assessment)?
- What would be the probability of this failure to happen (probability quantification - quantitative risk assessment)?
- If it happens, which consequences are expected (impact assessment - quantitative risk assessment)?

6.2 Risk assessment methodologies

Risk management is an integral component of CO₂ storage operations (including site selection, site characterization and storage system design), comprising risk assessment and the development of mitigation, monitoring and remediation strategies. The overall aim of risk assessment is to investigate the storage system's behaviour over time on the basis of any potential scenario compromising the storage integrity. Because the geologic storage of CO₂ is in the development phase, at this moment there is not one unique, standardized methodology for assessing associated risks as yet. For CCS projects, potential adverse effects on health, safety, and environment (HSE) could result from elevated CO₂ levels. The exposure may stem from possible accidents/failures during and after CO₂ injection. To identify the probability of occurrence and the impact of the undesirable events, and to deal with uncertainties in a comprehensive and transparent way, the application of a well-established methodology and framework is required for CCS projects.

A distinction needs to be made between qualitative and quantitative methods, as the evaluation of well integrity for CCS operations can be achieved by employing either assessment methodologies. In general a qualitative assessment will precede quantitative evaluations.

6.2.1 Qualitative assessment

Qualitative risk assessment constitutes of hazard identification, analysis and prevention. The hazards involved are site-specific events leading to undesirable consequences. A qualitative approach can be adopted for addressing well bore issues. Such methodology is aimed at the identification of hazards that could occur during injection operations as well as in the post-injection period. Hazards can be defined in terms of combinations of system properties and/or events that may lead to undesired consequences. In a CCS

context, migration of CO₂ out of the storage system, leading to elevated levels in the shallow subsurface or atmosphere, is considered to be the most significant general threat.

In order to define all conceivable events and processes that could be relevant, dedicated assessment techniques are being used that aid their identification. After the identification of scenarios numerical models can be created to quantitatively assess them, predicting the performance of critical parameters over a specified time frame. Critical parameters regarding well integrity are, for instance, cement thickness, corrosion rate, plug length etc.

Qualitative risk assessment methodologies aimed at the evaluation of CO₂ storage operations (e.g. TNO FEP analysis and Quintessa FEP analysis; see Table 6.1) are described in more detail in Sections 6.3.1 and 6.3.2.

6.2.2 *Quantitative assessment*

Quantitative assessment is defined as the analysis to predict the evolution and performance of a given system with respect to relevant parameter selection. In the case of well integrity the assessment comprises the analysis of the behaviour of a single or multiple wells in a CO₂ storage system over appropriate time scales and volumetric quantities. Quantitative risk assessment possesses deterministic and probabilistic elements. The choice between the two approaches depends among others on the number of the wells in the CO₂ storage project. If a storage option exhibits few existing abandoned wells, each well can be addressed by an individual deterministic risk analysis. Considering a storage option revealing numerous wells, a deterministic approach on an individual well base is hardly applicable. Instead, wells properties (e.g. cement permeability) are generalized for all existing wells or groups of wells ('well families') and are expressed with uncertainty ranges.

6.3 **Assessment of wellbore integrity**

The integrity of the well bore in CO₂-rich environments has been raised as the area of the highest concern with respect to the long-term effectiveness of CO₂ storage in geological reservoirs.

Most of the well integrity issues stem from casing pressure and cement problems which eventually hinder the hydrocarbon production and significantly raise the operational expenses. Moreover, the presence of CO₂ in any wellbore environment will introduce more issues and should be addressed for CCS applications. Previous meetings addressed the importance of using CO₂ resistant materials and other equipment specifically designed for CCS applications to reduce the frequency of the failure of wells. It was clearly stated that promising a 'leak-free well' with conventional methods will not be possible. Therefore prospective drilling operations may focus on remedial and preventive tailor-made protocols.

However, there is a major issue playing a crucial role for the uncertainty of the wellbore integrity and the current status of wells. It has to be noted that CO₂ injection wells, constructed according to recent standards and monitored during after injection operations, do not represent a major risk factor. Instead, existing older abandoned wells, highly abundant at many potential storage sites, e.g. depleted oil fields, pose a significant risk due to obsolete non-CO₂ specific construction and abandonment practices. In the following, several state-of-art risk assessment approaches are described.

Table 6.1 Characteristics of Well Assessment methodologies

Well Assessment methodology	Qualitative analysis	Quantitative analysis	HSE analysis	Simulator	Decision tool
TNO-CASSIF ¹	FEP-based Scenario Analysis	N/A			X
The Generic CO ₂ Geological Database ²	FEP-based Scenario Analysis	N/A			X
Data mining ³		Semi-quantitative			X
Performance and Risk Management methodology (P&R TM)+ Simeo TM -Stor ⁴		Probabilistic	X	X	X
Semi-Analytical Model and Monte Carlo Simulation ⁵		Probabilistic		X	
CO ₂ -PENS ⁶		Probabilistic	X	X	X

¹ TNO; Yavuz et al. (2008)

² Quintessa; Preston et al. (2005)

³ Watson and Bachu (2007)

⁴ Le Guen et al. (2008); Meyer et al. (2008)

⁵ Kavetski et al. (2006)

⁶ Viswanathan et al. (2008); Stauffer et al. (2009)

6.3.1 TNO's CASSIF and FEP database

The Carbon Storage Scenario Identification Framework (CASSIF; Yavuz et al., 2008) is based on three major CO₂ release scenarios (well, fault or seal) from where the relevant risk factors are identified. The risk factors of the major scenarios are forming the assessment basis. A questionnaire, to be completed by the experts, has been designed to get an initial overview of potentially important risk factors. The interface facilitates the online use of the so-called FEP database and a risk terminology glossary. Together with real-time scenario formation, these improvements will greatly enhance the speed, transparency and comprehensiveness in the creation of subsurface CO₂ release scenarios.

The acronym 'FEP' refers to 'Features', 'Events' and 'Processes' relevant to describing the state of a system of interest at any time, or the processes that take place. In the scope of this study the 'system of interest' consists of all elements characterizing the storage site. The application of Features, Events, and Processes (FEP) to describe the evolution of underground storage systems evolves from its first state. This evolution is called a scenario where case specific events with undesirable outcomes are addressed.

As was described above, the Carbon Storage Scenario Identification Framework is based on the three major CO₂ release scenarios (well, fault or seal) from where the relevant risk factors are identified. The structure of CASSIF has been designed to get an initial overview of potentially important risk factors. CASSIF facilitates the online use of the FEP. For the well integrity case, 3 subjects are being addressed in qualitative terms (Figure 6.1). Subjects include various risk factors from cement, casing and operational themes which might change the overall integrity of well during injection and post injection phases.

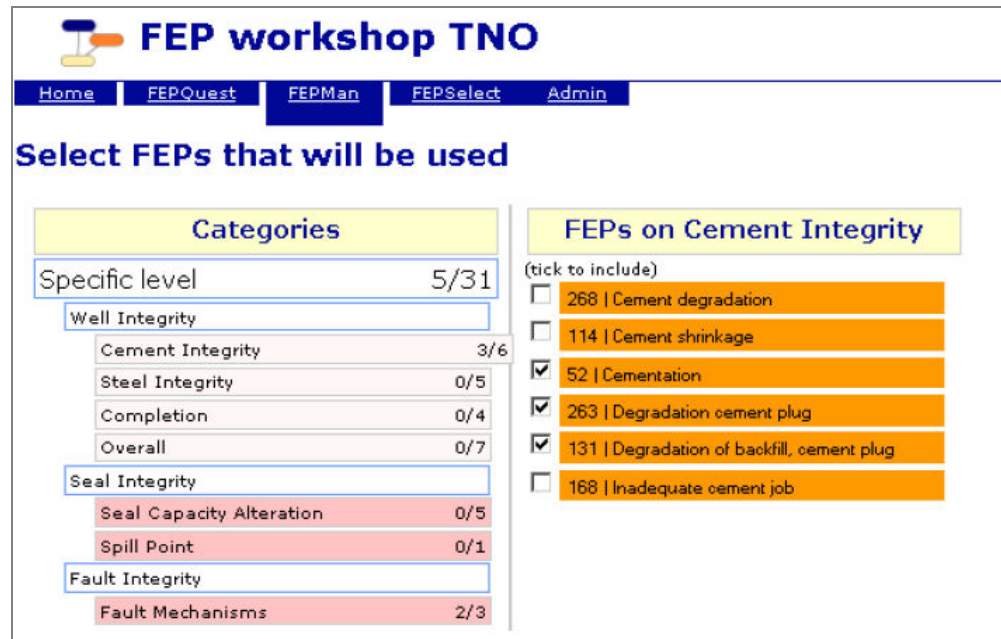

Figure 6.1 Well integrity section from CASSIF.

6.3.2 The Generic CO₂ Geological Database

The Generic CO₂ Geological Database was originally developed by Quintessa Ltd., UK as a contribution to the IEA GHG Weyburn CO₂ Monitoring & Storage Project (e.g. Preston et al., 2005). Continued development of the database was supported by IEA-GHG and BERR. The database represents a qualitative tool to support risk assessment, based on the principle that CO₂ storage systems can be described in terms of features, events and processes (FEPs) associated with geological storage of CO₂. The database was inspired by the OECD / Nuclear Energy Agency FEP Database for Geologic Disposal of Radioactive Waste (<http://webnet.oecd.org/wbos/>).

Due to the generic character of the database, the FEPs relate neither to specific storage concepts nor to specific sites. Instead, the approach is to use the database as a cross referencing and auditing tool for site-specific FEP studies. The database currently contains 178 described FEPs, selected with respect to long-term safety and performance of CO₂ storage, after injection has ceased and boreholes have been closed. The tool is accessible in the public domain (<http://www.quintessa.org/co2fepdb/PHP/frames.php>). The database exhibits a hierarchical structure consisting of 1) categories 2) classes 3) FEPs and (when necessary) 4) sub-FEPs. The eight categories are arranged as follows:

1. Assessment Basis
2. External Factors
3. CO₂ Storage
4. CO₂ Properties, Interactions & Transport
5. Geosphere
6. Boreholes
7. Near-Surface Environment
8. Impacts

The borehole category, which describes FEPs associated with wellbore leakage-related risks, is subdivided in two classes: 1) Drilling and completion, 2) Borehole seals and abandonment, each containing several FEPs (Figure 6.2).

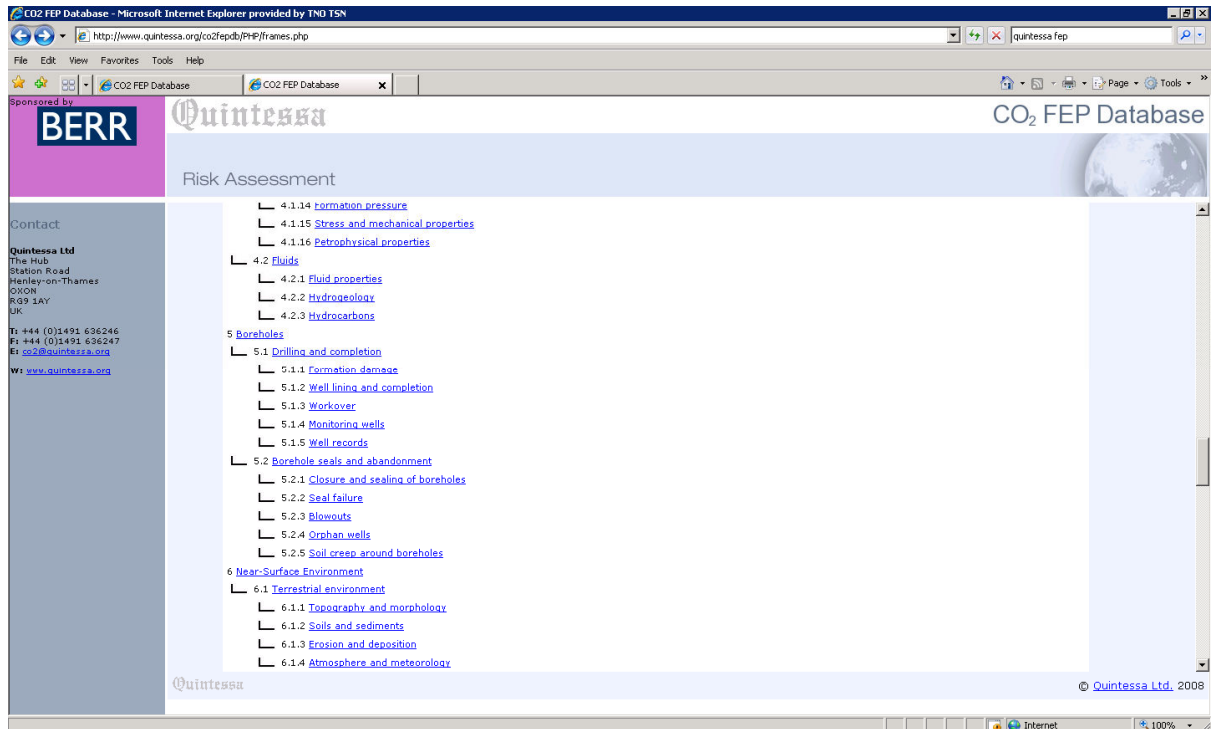

Figure 6.2. Screenshot of the FEP database showing the structure of the borehole category (www.quintessa.org).

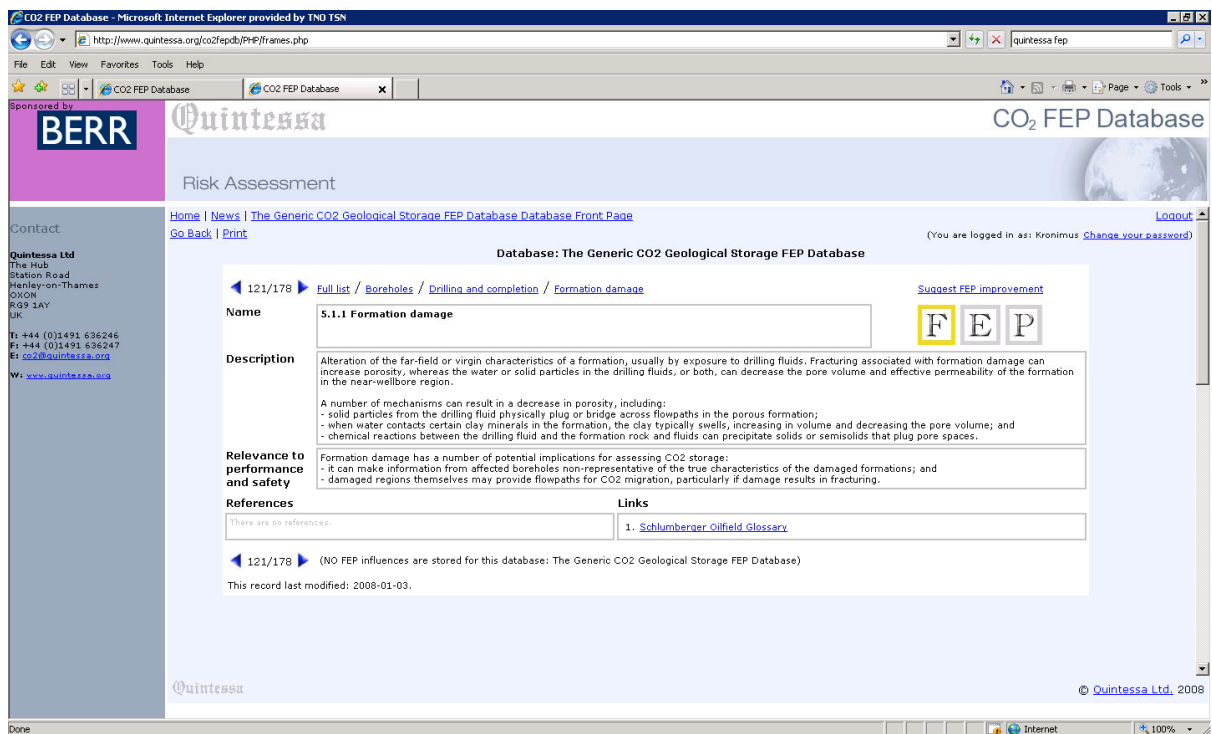

Figure 6.3. Screenshot of the FEP 5.1.1 "Formation damage" (www.quintessa.org).

The boreholes category “is concerned with the way that activity by humans alters the natural system. Boreholes used in the storage operations and those drilled for other purposes are relevant to the long-term performance of the system” (www.quintessa.org). Each FEP entry contains 7 kinds of information: 1) name of the

FEP; 2) FEP description, in many cases accompanied by an illustration; 3) relevance of the FEP to performance and safety; 4) references; 5) web links; 6) FEP number; and 7) date of last modification. As an example, Figure 6.3 shows the content of FEP 5.1.1 'Formation damage'.

A search engine has been implemented and the database can be browsed for FEPs. A list of references and links can be displayed. More detailed insights into the approach are provided on the Quintessa Ltd. website (www.quintessa.org). This approach covers the qualitative aspect of the risk assessment allowing selecting the major well bore integrity issues to be addressed in the quantitative assessment later on.

6.3.3 Leakage evaluation by data mining

Potential CO₂ storage reservoirs are often intersected by a vast number of abandoned wells, each representing a potential leakage pathway. One strategy for evaluating and ranking abandoned wells relevant to the integrity of an envisaged storage option is data mining of well information collected by regulatory agencies, particularly with focus on surface casing vent flow (SCVF) and gas migration data (GM). A corresponding approach conducted by Watson and Bachu (2007) considered stored data on more than 315,000 oil, gas and injection wells in the province of Alberta, Canada recorded up to the end of 2004. The data have been collected by the Alberta Energy and Utilities Board (EUB), the regulatory agency in Alberta (now the Energy Resources Conservation Board). The agency records well and production data including construction details and SCVF/GM data. SCVF is caused by gas entering the exterior production casing annulus from a source formation below the surface casing shoe, resulting in a gas flow to or pressure built-up at the surface. SCVF can be measured at the surface casing vent of a well (Figure 6.4). GM is an effect of gas migrating outside of the cemented surface casing. It may be caused by deep gas originating from formations below the surface casing shoe migrating upwards past the surface casing shoe, potentially caused by poor surface casing cement or fractured cement or rock. GM may also originate from shallow gas accumulations located above the surface casing shoe and leaking through a poorly cemented surface casing. In Alberta, testing of SCVF and GM is conducted as per regulatory requirements. More details on the testing procedures are described in Watson and Bachu (2007).

Major focus of the investigation has been to find factors contributing to wellbore leakage in the context of CO₂ storage. To reach this goal, correlations between SCVF/GM and economic activity, technological changes, geographic parameters, completion and abandonment practices as well regulatory changes have been considered. Additionally, casing inspection logs indicating internal as well as external corrosion for 500 wells have been considered and compared to cement bond logs. Groundwater level records have been used for correlation with surface casing, annular cement and casing failure depths.

Generally, three conditions have to be met for a leak to occur: 1) A leak source, 2) a driving force, such as buoyancy or a head differential, 3) a leakage pathway. CO₂ storage operations fulfil two of these conditions: a potential leak source is represented by the injected and stored CO₂ which, at the same time, delivers the driving force due to CO₂ buoyancy and an increased reservoir pressure caused by injection operations. Thus, the additional presence of a leakage pathway will inevitably result in a leakage scenario. The main leakage pathways associated with wells include: 1) Poorly cemented casing/hole annulus 2) casing failure 3) abandonment failure.

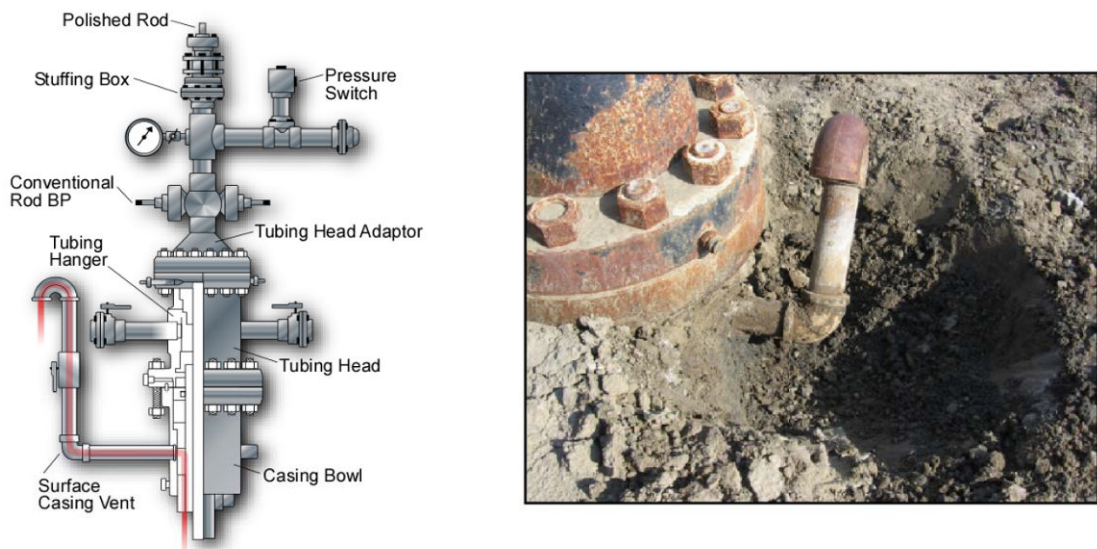

Figure 6.4. Schematics and picture of a typical wellhead with surface casing vent installed (Watson and Bachu, 2007).

These potential leakage pathways can become effective without additional chemical interactions of CO₂ such as cement degradation and casing corrosion. The study does not differentiate for seepage/leakage to different “compartments” (e.g. atmosphere, aquifers). Instead it is assumed that any leak of CO₂ from the storage site or natural gas from the reservoir is undesirable.

Abandonment methods in Alberta include three scenarios: 1) Wells drilled and abandoned, 2) wells drilled, cased, completed and abandoned, 3) wells drilled, cased and abandoned. Descriptions of these scenarios and further information on regulatory requirements and testing methodologies with respect to SCVF/GM can be found in Watson and Bachu (2007).

The data mining approach relates a number of well features to the magnitude of impact on the leakage risk. The well features were grouped into three categories: 1) Factors showing no apparent impact 2) factors showing minor impact 3) factors showing major impact.

6.3.3.1 Factors showing no impact

- *Well age*: The expectation of higher leakage rates of older wells due to less elaborate construction and materials was not supported by the data. While the oldest recorded abandoned well in Alberta dates back to 1893 and the first commercial gas field was developed in 1901, the compulsory SCVF/GM testing did not come into effect until 1995. Thus, corresponding reports for many wells abandoned prior to 1995 were not available, resulting into a serious distortion of the analysis of the age factor. However, the latter is indirectly covered by other factors relating to construction and abandonment practices.
- *Well operational mode*: Well operational mode (oil and gas production, water and solvent injection, disposal of liquid waste or acid gas) did not reveal any effect with respect to wellbore leakage based on SCVF/GM data. Thermal operation modes such as steam assisted gravity drainage (SAGD) and steam injection were expected

to exhibit an enhanced impact due to thermal stress on the well materials. However, this could not be verified, probably because these wells are more recent and largely still operational. This results in a lack of data due to few abandoned wells of this operation mode and too short observation periods. The impact on thermal operation modes will not be ascertainable until a significant portion of such wells will be subject to abandonment.

- *Completion interval*: Depth of the SCVF/GM source and depth of completion intervals revealed no correlation. This was supported by casing and cement logs, exhibiting that the majority of wells are characterized by a good cement quality and zonal isolation deep in the wellbore.
- *H₂S or CO₂ presence*: The presence of hydrogen sulphide and CO₂ in produced hydrocarbons was investigated for a possible impact on internal and external casing corrosion, which was not supported by the available data. Sour gas well operations in Alberta are characterized by certain features enhancing casing protection. First, such operations require the well equipped by packers, to protect the inner casing surface. Second, in Alberta, H₂S usually occurs in deep formations, where the majority of wells exhibit a good cement bond.

6.3.3.2 Factors showing minor impact

- *Licensee*: Various operators using different abandonment practices may result in different sealing efficiencies of wells subject to abandonment. Table 6.2 reveals the licensee-dependent variation of the leakage rates. However, an unequivocal correlation was not evident.

Table 6.2. Licensee comparison in terms of well leakage occurrence (Watson and Bachu, 2007).

Licensee	% Total Well	% Reported SCVF	% Reported GM	Ratio SCVF:Well Total	Ratio GM:Well Total
Licensee A	11.3	7.5	36.2	0.66	3.2
Licensee B	35.4	43.2	52.6	1.2	1.5

- *Surface casing depth*: Surface casing depth was not found to influence the sum of leakage by SCVF/GM. However, there is an influence on whether leakage occurs as SCVF or GM. Generally, greater surface casing depth reduces the occurrence of SCVF while GM increases, supporting the indication that GM sources are typically situated above the surface casing shoe depths and that GM is influenced by surface casing cementing practices.
- *Total depth*: SCVF/GM increases slightly with total well depth, attributed to the generally increasing uncemented upper interval of deeper wells, providing enhanced hydraulic communication with source formations.
- *Well density*: In areas exhibiting high well densities, occurrence of well-to well crossflow can potentially result in enhanced leakage rates of wells subject to inflow due to such migration phenomena. This hypothesis was not supported by the available data but was indicated from other work. This might refer to the existence of more recent wells not yet sufficiently tested and characterized by better cementation.

- *Topography*: River valleys may represent zones of higher leakage risks due to removal of overburden and corresponding decline of hydrostatic pressure, potentially resulting in shallow overpressured zones. However, the data set investigated revealed no significant influence of topography on SCVF/GM.

6.3.3.3 Factors showing major impact

- *Geographic area*: In certain areas within the province of Alberta testing of all wells is required, whereas in other areas the requirements are less strict. One area within the province subject to testing requirements for all wells exhibited a more frequent occurrence of leakage compared to the entire province. However, it is not clear whether this finding refers to the different testing conditions.
- *Wellbore deviation*: Figure 6.5 shows that leakage by SCVF/GM occurred significantly more often related to deviated wells, while the impact of well deviation on the ratio of SCVF to GM was minor. This may be caused by mechanical aspects, such as casing centralization and cement slumping. Any well revealing a total depth exceeding true vertical depth was considered a deviated well. It has to be noted that in case of vertical drilling, non intended well deviation may lead to an increased penetration surface within the caprock. This may impact on the cap rock integrity.

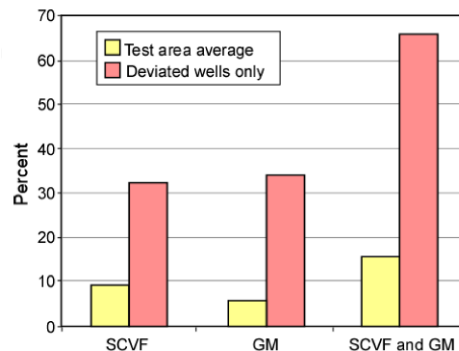

Figure 6.5. Comparison of leakage rates between deviated wells and the average of all wells in the test area (Watson and Bachu, 2007).

- *Well Type*: Cased abandoned wells account for 98% of all leakage cases reported. The rest refers to wells drilled and abandoned. This significant difference may rely on more stringent abandonment requirements for drilled and abandoned wells. Completed wells exhibit an additional leakage potential due to perforated intervals.
- *Abandonment Method*: In Alberta, cased and completed wells are predominantly abandoned by bridge plugs capped with cement. Based on the data set and experience 10% of these bridge plugs will fail over a period of centuries allowing formation fluids to enter the well bore. Alternative methods, such as placing cement plugs across completed intervals using a balanced plug method, or setting a cement retainer and squeezing cement through perforations are expected to reveal lower failure rates. The final barrier in a well is the welded casing cap, known to be highly unreliable. However, leaking caps may contribute to reduce well overpressure and can act as an early warning system for compromised well integrity.

- *Oil price and regulatory changes*: The data set reveals a significant positive correlation between SCVF/GM occurrence and oil price between 1973 and 1999. This can be explained by the relation between exploitation activity and equipment availability. Satisfaction of a high demand with limited equipment resources impacts on primary cement placement practices. The implementation of heavy oil production by thermal recovery, high well densities and application of diverse well technologies which accompanied the oil price rise additionally increased the likelihood of well leakage. The correlation of the oil price and SCVF/GM starts to diverge in 2000 (oil price rises while SCVF/GM occurrence ceases). This may be due to SCVF/GM being detected primarily at the time of abandonment. Wells drilled since 2000 are generally not yet abandoned these well leakages may not yet be reported or detected.
- *Uncemented casing/hole annulus*: A low cement top was found to be the most important indicator for SCVF/GM. Low cement top is also the main cause for external casing corrosion. Watson and Bachu (2007) stated the following conclusions based on the analysis of well logs for casing inspection and cement bond quality:
 - The majority of significant corrosion occurs on the external wall of the casing
 - A significant portion of the wellbore is uncemented
 - External corrosion is most likely to occur in areas of no or poor cement

Furthermore, it was determined that the top 200 m of the cement annulus is generally of poor quality and that the vast majority of SCVF/GM originates from formations not isolated by cement.

The majority of casing failures have been attributed to regions of poor and no cement in the annulus. Evaluation of well logs revealed that cement quality typically improves deeper in the well and particularly across completed intervals.

6.3.3.4 *Prediction of wellbore potential for leakage based on well attributes*

Based on the results discussed, a decision tree was developed in order to estimate and rank leakage probability with respect to SCVF/GM (Figure 6.6) for abandoned wells. This scheme employs the following aspects:

- Well type: Drilled and abandoned wells are far less prone to leakage than cased wells.
- Regulatory changes: As of 1995 regulations became more stringent; wells abandoned after 1995 should exhibit less probability of leakage, as any detected leakage would have provoked counter measures prior to abandonment.
- Oil price: Wells drilled before 1995 exhibit positive correlation between leakage and oil price due to reasons discussed above.
- Geographic position: Is the well situated in a region where wells statistically reveal enhanced leakage or where the testing conditions are applied in a stricter manner?
- Cement top requirement: Data mining revealed that absence of cement at the upper wellbore is probably the most reliable predictor for SCVF/GM and casing failure.

In general, this method is suitable for measuring uphole leakage. It is a decision tool for distinguishing between zones in intended storage area exhibiting different risk levels.

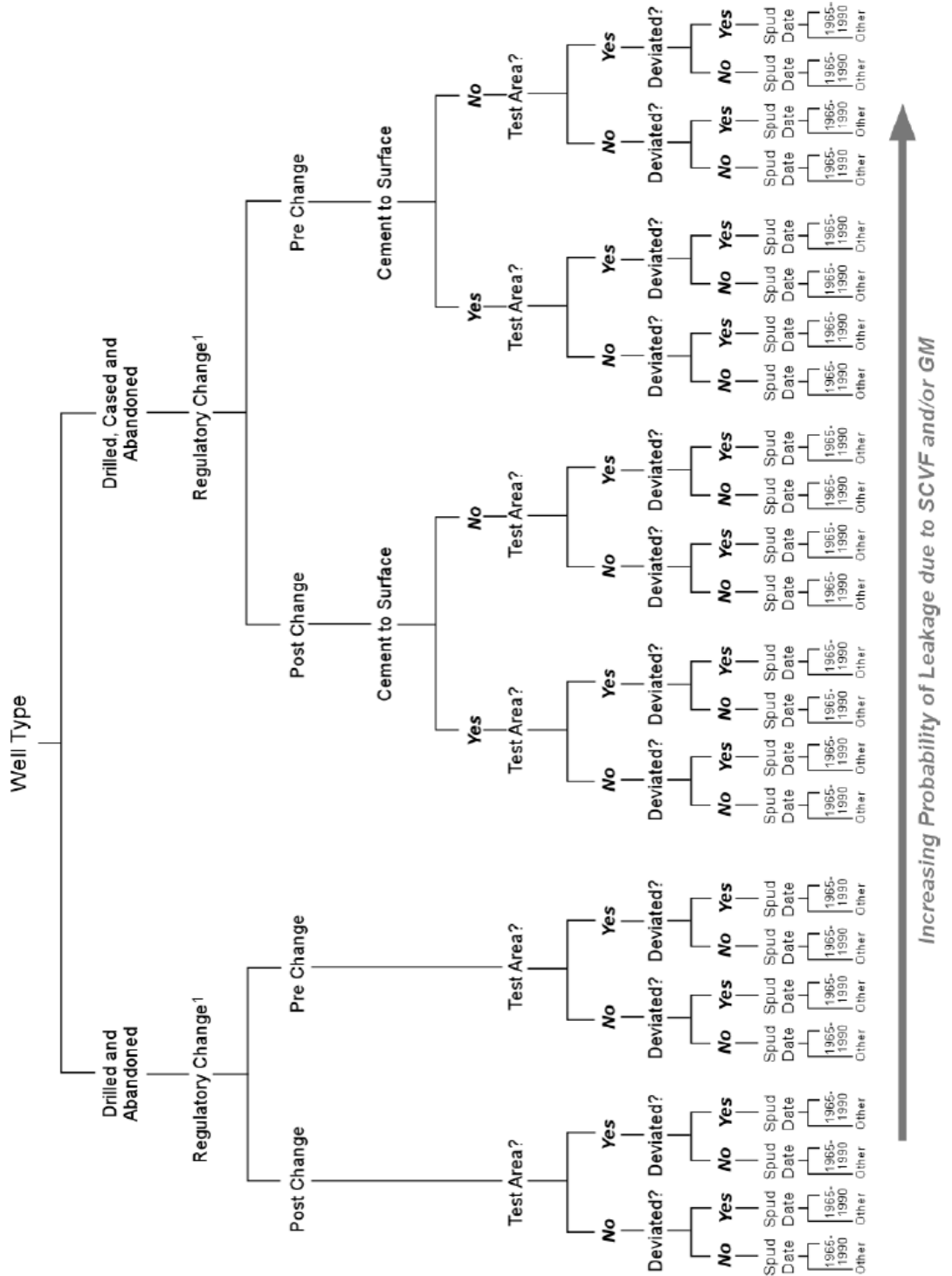

Figure 6.6. Decision tree for assessing the potential for well leakage inside and outside surface casing (Watson and Bachu, 2007).

6.3.4 Performance and Risk Management methodology (P&RTM)

The Performance and Risk methodology (P&RTM), developed by Oxand S.A., represents a quantitative risk-based approach for well integrity management, allowing identification and quantification of risks within CO₂ injection and storage operations over various time scales (co-injection, post-injection, abandonment). A detailed description reaching beyond the scope of this overview can be found elsewhere (Le Guen et al., 2008; Meyer et al., 2008). The methodology is intended as a decision support tool for stakeholder parties involved in planning or operating a CO₂ storage project as it can be applied for setting up risk mitigation strategies and emergency plans with respect to CO₂ leakage or seepage through well completions. Additionally, this risk approach provides elements to demonstrate performance and safety of CO₂ storage to authorities, which is necessary to get a permit for operations. Major focus lies on evaluating risks of CO₂ leakage into subsurface compartments (e.g. aquifers) or seepage to the atmosphere caused by ageing processes (e.g. cement degradation, casing corrosion), potentially leading to migration channels.

The major working steps of the method are:

- Identifying system and sources of degradation by system characterization and functional analysis
- Quantifying the criticality (defined below) of scenarios by modelling approaches in terms of probability and severity
- Establishing a risk mitigation plan

Performance assessment refers for example to the ‘containment performance’ of a well, defined as the “capability to ensure a good zonal isolation in order to contain the injected CO₂ in the geological reservoir over the intended lifespan of a storage reservoir” (Le Guen et al., 2008). Risk is perceived as the probability of a loss in containment performance resulting in an impact on specific stakes. Criticality is defined in this context as the multiplication of the impact on health, safety and environment of a hazardous situation times the probability of the situation to occur. The essential component of the approach is a well completion and leakage simulator (SimeoTM-Stor) allowing the prediction of the quantitative impact of leakage paths along the wellbore. This implies the opportunity to establish a prognosis with respect to well integrity as a function of time covering periods from decades to millennia and thus, the feasibility for assessing the containment performance of a potential storage site. One of the main features is the expression of risks in terms of criticality (defined above). Additionally, the approach can indicate the requirement of preventive or corrective measures or monitoring for mitigating unacceptable risk levels. To summarize, *main objectives are the identification and quantification of the risk-associated criticalities and risk-treatment by selection and implementation of risk mitigation actions.*

The process chain of the approach, illustrated in Figure 6.7, consists of a data collection survey followed by a functional analysis of the system, serving as input for a static well model. The latter, in turn, acts as an input for a dynamic model, able to predict degradation of well components as a function of time and to quantify CO₂ leakage along the wellbore.

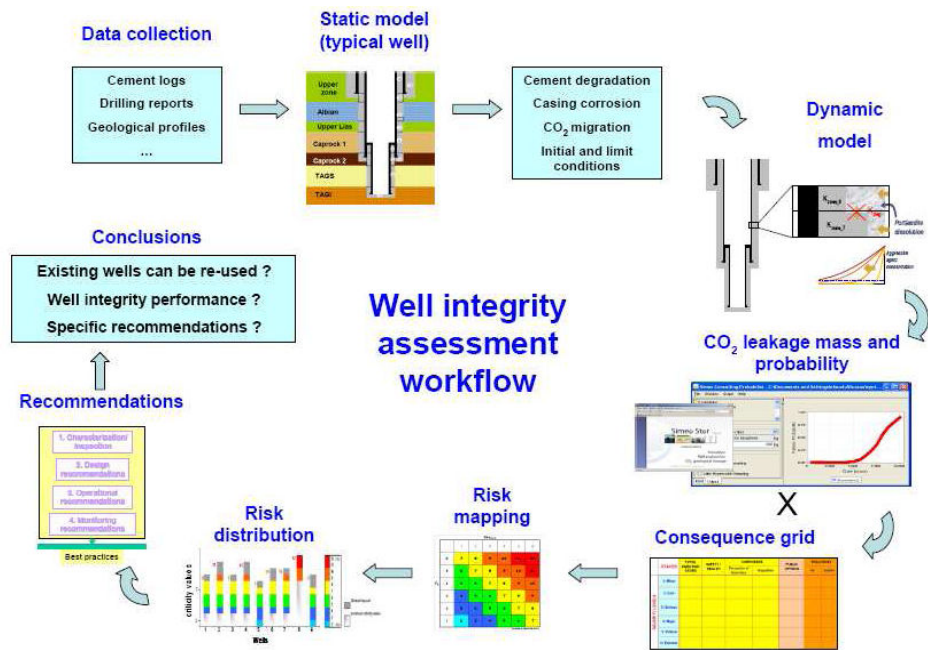

Figure 6.7 Workflow of the P&RTM methodology (Le Guen et al., 2008).

Based on the parameters of the static and dynamic models, and associated uncertainties, scenarios are defined and then evaluated numerically. Simulation results enable to identify leakage pathways along the wellbore and the amount of leaking gas towards different targets (fresh water aquifers, surface, etc) over time. Severity levels for each identified scenario are assessed from CO₂ leakage simulation and a consequence grid relating a certain performance loss to the severity of the resulting consequence for different stakes (project performance, safety, environment, public opinion, etc.). The probability level of a risk is given by the probability of the scenario and a frequency grid. Finally, risk mapping allows identification and ranking of risks for all wells relevant to CO₂ injection and storage operations at the site to be assessed. Practically, risk mapping is performed by filling a colour coded grid with each couple (probability, severity level) corresponding to all scenarios which lead to CO₂ leakage. These results then lead to recommendations and conclusions to support decision-making and to establish site-specific risk mitigation measures. The workflow will be described in the following in more detail.

6.3.4.1 Data collection

The data collection survey, representing the initial step in the process chain, targets on data retrieval from all available documents referring to wells and their surroundings, including well descriptions (trajectory, completion details) and characteristics of the wells' components (e.g. features of tubulars, packers and cement). Such information can be found in well completion design documents, drilling and cementing reports, cement and corrosion logs, production history and workover reports. Furthermore, all formations intersected by the well are to be characterized (by log and core data) in order to define boundary conditions for the modelling approach later on.

Table 6.3. Examples of a components and functions resulting from a functional analysis with corresponding failure modes, causes and effects (Le Guen et al., 2008).

Components	Function	Failure mode	Causes	Effects	
Tubulars	(F1): to resist formation fluids pressure	Loss of mechanical resistance	Corrosion	Breaking and collapse	
	(F2): to ensure sealing with respect to formation fluids	Loss of sealing with respect to the formation fluids		Fluids can penetrate the well	
	(F3): to resist CO ₂ pressure and temperature	Loss of mechanical resistance	Corrosion, erosion	Breaking and collapse	
	(F4): to ensure sealing with respect to injected CO ₂	Loss of sealing with respect to the CO ₂	Overpressure	Shrinkage due to temperature variation	Loss of bond between casing and cement
				Operator	Cracking of casing
(F5): to resist formation pressure (creep)	Loss of mechanical resistance	Corrosion	CO ₂ can penetrate the well	Collapse and total effort transfer on cement sheaths	
Cement	(F2): to ensure sealing with respect to formation fluids	Loss of sealing with respect to the formation fluids	Chemical degradation and/or leaching	Appreciable increase in permeability	
	(F4): to ensure sealing with respect to injected CO ₂	Loss of sealing with respect to the CO ₂	Cracking	Severe increase in permeability	
			Chemical degradation and/or leaching	Appreciable increase in permeability	
	(F5): to resist formation pressure (creep)	Loss of mechanical resistance	Loss of cement sheaths and transfer of the efforts to the casings	Creep of the cement sheath	

6.3.4.2 System description and functional analysis

Before being able to conduct a risk assessment, the physical environment of the well has to be taken into account, including sub-systems potentially able to interact with the well (formations above the storage reservoir and the cap rock, subsurface fluids, shallow subsurface/soil, surface or sea floor, atmosphere). The time of the P&RTM approach initiates when CO₂ enters the well and covers decades to millennia, depending on the purpose of the study. The functional analysis requires defining components, functions and sub functions, and associated failure modes. Well components are for example tubulars, packers, cement sheaths, and cement plugs. Such well components are related to specific functions, e.g. a packer refers to hydraulic separation. This function can be decomposed in several subfunctions such as to resist subsurface pressure and temperature as well as to resist chemical degradation by pore fluids. Specific failure modes can be allocated to each function or subfunction of a component, leading to deterioration or complete failure of the function. Furthermore, the specific failure modes can be referred to causes and effects (Table 7).

6.3.4.3 Consequence grid

As outlined above, criticality is defined as the interaction of probability of occurrence of a scenario and the severity of its impact when occurring (related to the amount of CO₂ leaking from a reservoir to a specific target (e.g. environment, aquifer pollution, humans, economy, etc)). A consequence grid relates stakes involved into CO₂ storage

operations with specific severity magnitudes and their qualitative or quantitative impact (Table 6.4).

The representation of a consequence grid refers to a matrix: each column represents an individual stake involved in CCS operations (stakes to be defined by project management). The rows of the matrix refer to different impact levels on each stake (impact levels to be defined by each stakeholder). The matrix cells reveal a stake-specific qualitative or quantitative degree of impact. Consequence grid is project and site specific.

Table 6.4. Example of a consequence grid including different stakes and severity levels (Le Guen et al., 2008).

Severity levels	Stakes					
	Personal injury	Public opinion	Additional OPEX-Financial	CO ₂ storage performance goals	Corporate Perception of know how	Environment
1: Minor	/		< 0.1 M\$	Loss < 0.01 % of injected CO ₂	no impact	
2: Low	no impact		[0.1 - 0.5[M\$	Loss = [0.01-0.05[% of injected CO ₂	Technical skill non affected (project is considered as a test)	
3: Serious	First aid		[0.5 - 1[M\$	Loss = [0.05-0.1[% of injected CO ₂	Top Management becomes suspicious about technical skill	
4: Major	Medical treatment		[1 - 5[M\$	Loss = [0.1-0.5[% of injected CO ₂	Lack of confidence from the Top Management - Request for a demonstration of technical feasibility	
5: Critical	Serious personal injury		[5 - 10[M\$	Loss = [0.5-1[% of injected CO ₂	Questioning from the Top Management about the technical capability to assume CO ₂ storage projects	
6: Extreme	Serious pers. injury, possible permanent injury		>= 10 M\$	Loss >= 1 % of injected CO ₂	Termination of the project - Field is not considered as a CO ₂ storage field	

6.3.4.4 Static model building

A preliminary assessment for well integrity is based on using all available characterization measurements and their associated uncertainties. For example, the component casing is associated with the characteristics diameter, thickness, overlaps, shoe depths, etc., whose quantities may reveal uncertainties. Cement evaluation can be achieved by interpretation of logging data. To be able to put the well data into the geological context and to keep the model simple, a segmented well model is generated, representing a 2D axi-symmetric description of the well, where each layer is characterized by constant properties. Segmentation processing is applied for well components, formation layers, heterogeneity of cement sheaths and the quality of cement bonding. Wells revealing similar designs, completions, cement sheaths and intersect similar geological settings can be grouped to 'well families' described by a 'typical well', representative for the well family.

6.3.4.5 *Dynamic modelling*

The static model is used as an input for a dynamic simulator, targeting on the prediction of the degradation of the well components exposed to CO₂ and/or other interactors (e.g. formation fluids) as a function of time, achieved by numerical simulations. Furthermore, CO₂ leakage rates to any point of interest (e.g. aquifer, atmosphere) can be calculated. Further input for the simulator are the various component-specific degradation mechanisms, the associated chemical kinetics and boundary conditions. The model can be calibrated by correlation with laboratory experimental results and/or in-situ data, e.g. on steel corrosion. Initial and boundary conditions like a hydrostatic pressure profile and fluid saturations of intersected formations have to be specified. Cement sheaths are regarded as porous media, saturated with water and CO₂. Darcy's law is applied to describe the fluid flow within well's system. The model refers to the Van Genuchten law to relate cement pore water saturation to flow properties.

6.3.4.6 *Risk assessment*

The initial state of risk assessment implies the definition of leakage scenarios, resulting from state of well components. Quantitative descriptions of well components, degradation mechanisms, kinetics, and initial as well as boundary conditions are subjects to uncertainties which are considered during static and dynamic modelling. Consequently, CO₂ leakage scenarios are calculated relying on probability distribution functions to account for the uncertainty range in each the input parameters. This will result in a specific probability for each scenario.

The outcome of a leakage scenario modelling is a CO₂ leakage rate as a function of time referring to a selected spatial point, e.g. a point in an aquifer or at the surface. The leakage rate calculated for each relevant leakage scenario is converted into a severity level according to the consequence grid and, after involving the scenario probability, transferred into a criticality value. This allows the quantification of all pre-defined risks. Compilation of all risk scenarios for a certain well in a colour coded graph and subsequently relating probability and severity of all identified risks, leads to risk map, which is a powerful tool to visualize the envelop of risks associated to the well integrity performance.

Such an approach for several wells leads to a high resolution risk assessment for all wells relevant for a CO₂ storage site and enables their ranking in terms of criticality. When using 'typical well' approach for a well family (group of wells presenting similar characteristics), a reverse analysis of the risk map of a 'typical well' allows the generation of a risk map for each individual well of the family. This process is referred to as risk distribution.

6.3.4.7 *Risk treatment*

As full integrity of a storage option is neither realistic nor relevant, there has to be a definition of an acceptable risk threshold. A definition can be achieved relying on the stakeholders' perception of non-tolerable risks levels, by consideration of the objectives developed within Corporate Integrated Management Systems (CIMS) and through legal and regulatory requirements.

The component characteristics contributing to unacceptable criticality scenarios, termed risk sources, represent the base for setting up a mitigation plan. This results in recommendations for measures assuring that all risks are decreased and remain below the acceptable risk levels of wells relevant for a CO₂ storage option. Such measures are targeting on lowering the probability of a risk, its severity or both. They can be allocated to four types:

- Conduct additional characterization/inspection measures to reduce uncertainties

- Lowering Migration by workovers, treating risk sources detected after conducting additional characterizations/inspections
- Conduct operational best practices , e.g. casing pressure tests during injection operations
- Conduct monitoring approaches to observe the evolvement of the system during operations and to detect potential hazards prior to their occurrence

Such recommendations have to be established for each individual well within a storage site. The recommendations represent the final step to approve operations from the perspective of risk management.

6.3.5 *Semi-Analytical Model and Monte Carlo Simulations*

This summary is obtained and compiled from Kavetski et al. (2006) and details beyond the scope of this summary can be found in this article.

6.3.5.1 *Introduction*

Because of geological conditions and the existence of appropriate infrastructure, mature sedimentary basins are likely candidates for injection and storage of CO₂. These basins, for example in North America, more than a century of oil and gas exploration and production. This has resulted in many wells drilled; 400,000 in the Alberta Basin and more than one million in Texas. Thus, estimating the probability of CO₂ leakage along existing (abandoned) wells is an important part of any risk assessment study.

6.3.5.2 *Risk assessment*

In order to perform a reliable risk assessment, it is necessary to estimate the likelihood and magnitude of potential leakage out of the storage formations. This, in turn, requires the ability to model the migration of CO₂ plumes during and after injection. In addition, it is necessary to include all the wells in the mathematical description because they may be encountered by the CO₂ plumes. Furthermore, multiple geological formations need to be included in the description of the surface, because vertical migration of CO₂ is considered to be a central feature of the leakage problem.

In general, performing calculations based on this list of requirements is extremely time-consuming when using traditional numerical simulators. On top of that, the high degree of uncertainty associated with the hydraulic characteristics (for instance, poorly understood leakage pathways and effective permeabilities) and often even the location of the abandoned wells, make traditional simulations even more difficult, because many models have to be investigated.

Because of the high degree of uncertainty, a probabilistic analysis is necessary to estimate the likelihood of leakage and the confidence limits on these predictions. The system is strongly non-linear with respect to its (highly uncertain) hydraulic properties. In particular, it is believed that the effective permeability in abandoned wells is the dominant source of uncertainty in leakage predictions. Considering these uncertainties, the use of Monte Carlo methods becomes necessary to obtain leakage estimates under different permeability scenarios. Monte Carlo analysis requires multiple runs (hundreds or thousands) with different system properties sampled from a priori distributions. Existing, time consuming, numerical algorithms for multiphase flow are, therefore, not the most suitable way in Monte Carlo based risk assessments, because of time and hardware constraints. Therefore, a semi-analytical model for computationally fast estimation of CO₂ migration has been developed to replace the existing numerical algorithms.

6.3.5.3 Semi-analytical model

The semi-analytical method specifically focuses on the wells as the dominant transport mechanism and derives an approximation of the general multiphase equations. A detailed numerical description can be found in Nordbotten et al. (2005; 2009). A central component of the methodology is a model of radial CO_2 plumes developing around injection and leaky wells. The semi-analytical model uses plume masses around the injector and leaky wells as the primary variables. This model is based on the following assumptions:

1. Only two fluids are present in the system; saline water (brine) and CO_2 .
2. The CO_2 migration is solely advection driven.
3. The geological formations are homogeneous and horizontal, with alternating permeable (aquifer) and impermeable (aquitard) layers.

In addition, it is assumed that:

1. CO_2 plumes are radial symmetric in all formations,
2. All layers are spatial homogeneous,
3. Caprock formations are impervious,
4. The formation is horizontally layered and the wells are vertical,
5. Capillary pressure and thermal effects are ignored,
6. Leaky wells fully perforate each aquifer,
7. The flow rate is constrained by the available mass and the well segment permeability across the aquitard

Figure 6.8 shows the schematic of the system modelled by the semi-analytical approach. In general, any well may leak CO_2 to the overlying formations. In addition, it uses another semi-analytical model to determine the shape of the plumes and the pressures at all well locations in all layers. The latter model is used to identify the wells contacted by CO_2 plumes and to estimate the leakage flow rates. The magnitude of leaking is computed using a Darcy-type permeability function.

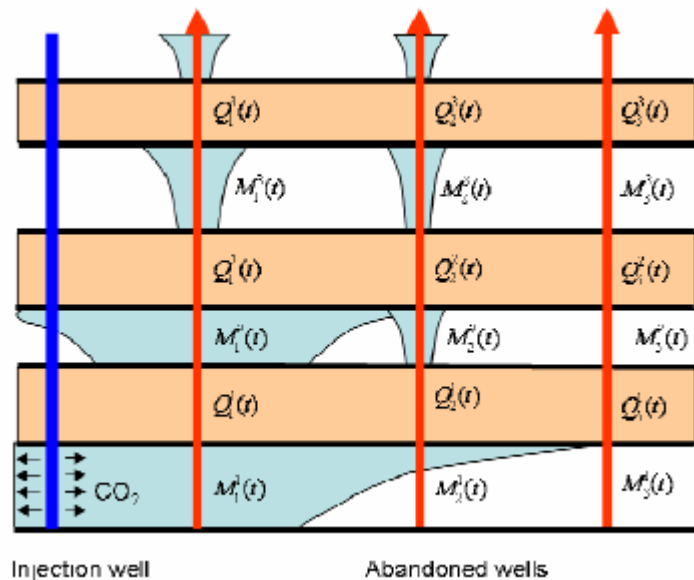

Figure 6.8. Schematic of injection and leakage, including leakage plumes and multiple layers of alternating permeable aquifers and impermeable aquitards. The flow rates are denoted by $Q(t)$ and the amount of mass by $M(t)$.

The semi-analytical model consists of the following (coupled) primary equations, adapted to the above listed assumptions:

1. Mass balance equations,
2. Well flow rate equations,
3. Pressure equations,
4. Plume shape equations,
5. Saturation equations.

This set of equations is solved numerically using time stepping algorithms and iterative solvers, because these equations are coupled nonlinear differential-algebraic equations.

6.3.5.4 *Case study: Alberta Basin*

Kavetski et al (2006) implemented the semi-analytical model into a Monte Carlo analysis. The Wabamun Lake formation in Alberta (30x30 km² and 500 wells) has been modeled to demonstrate the capabilities of the semi-analytical model. The distribution of the effective permeability is assumed to be bi-Gaussian. This means that two peaks are present; one corresponds to well-formed cement and the other to degraded cement. For this case study, 600 independent Monte Carlo realizations were performed based on this bi-Gaussian distribution to determine the leakage profile over 32 years. From these simulations output statistics, including statistics related to well leakage, can be generated. Because of the nature of the demonstration, no conclusions are drawn on the leakage profile. This demonstration, however, shows that the simulations based on the semi-analytical method can be performed within a reasonable amount of time. This is a major improvement compared to the traditional numerical methods.

6.3.5.5 *Future work*

So far, the capabilities of the semi-analytical model in a Monte Carlo framework are considered in case the the distribution of well permeabilities is well-known a priori. In practice, this is not the case. It is, therefore, intended to formulate the Monte Carlo problem in inverse form. This would imply that the well permeability distribution would be derived from given pre-defined maximum leakage rates to a known degree of confidence. Secondly, the computational runtime has significantly improved with respect to the runtime of traditional methods. Still, the runtime is strongly dependent on the well permeabilities and on the ratio of well permeabilities in adjacent well segments. This phenomenon is being studied in more detail. Further improvements of the method consist of:

1. More physically-based estimation of saturations in the wells,
2. Improved numerical algorithms for the nonlinear equations that arise in the semi-analytical formulation,
3. A new hybrid approach that allows traditional numerical solutions in the injection layer to be coupled with semi-analytical leakage solutions for the overlying formations.

6.3.6 *Probabilistic assessment of wellbore leakage using CO2-PENS*

CO2-PENS (predicting engineered natural systems) is a probabilistic simulation tool designed to incorporate CO₂ injection and sequestration knowledge from the petroleum industry to perform risk assessment of sites. CO2-PENS includes economic tools, as well as models for the physical and chemical interactions of CO₂ in a geologic reservoir (Viswanathan et al., 2008; Stauffer et al., 2009). The model links high level system models (i.e. a reservoir model) to the process level (wellbore leakage, chemical interaction of CO₂) and thus represents a hybrid coupled process and system model designed to simulate the following CO₂ pathways:

- Capture from the power plant
- Transport to the injection site
- Injection into geologic storage reservoirs
- Potential leakage from the reservoir
- Migration of escaped CO₂ either to compartments in the vicinity of the storage reservoir or into the atmosphere

Due to its modular architecture, the tool allows incorporation of additional process models by linking to dynamic linked libraries (DLL). Viswanathan et al. (2008) demonstrated the applicability of CO₂-PENS with respect to wellbore leakage simulation from a synthetic depleted oil reservoir by using a wellbore release model DLL, developed by the Princeton–Carbon-Mitigation initiative (CMI) group (Nordbotten et al., 2009). The simulated scenario assumes leakage of CO₂ through a plugged well and subsequent migration into an overlying aquifer and to the atmosphere. For the latter, the atmospheric model developed by Los Alamos National Laboratories has been used. Details of the applied atmospheric dispersion model are described in Viswanathan et al. (2008). Within the scope of the case study, leakage of 0.01% of the initially injected CO₂ has been assumed as the acceptable upper limit.

Simulation of wellbore leakage is complicated since the associated interactions and processes are not yet entirely understood. Wellbore cement permeability is identified as a key parameter in a wellbore leakage scenario and is difficult to estimate. Additionally, as the seals of storage sites are usually intersected by numerous wells, simulation approaches require probability distribution functions (PDF) with respect to potential failure mechanisms as input parameters to take account of uncertainties. A conceptual model of CO₂ leakage may be developed for any given well relying on PDFs of the quantities of the following processes:

1. Flow at cement-casing interface
2. Flow through the cement matrix
3. Flow through pathways created by bulk chemical dissolution of the cement
4. Flow through fractures in the cement
5. Flow through an open annular region due to inadequate cement placement
6. Flow at the cement-cap rock interface

For the case study, observations and experiences from an investigation on wellbore cements at Scurry Area Capital Reef Operations Committee (SACROC) have been adopted for a first attempt to establish PDFs enabling modelling of CO₂ leakage through wellbore cement. In order to obtain reliable PDFs, key processes have to be identified through a combination of experimental and theoretical information, which in turn, has to be validated with field analogues. Carey et al. (2007) reported on a cement core retrieved from a 55-year old well which was exposed to a CO₂ environment for 30 years due to EOR operations. The investigators concluded on the one hand that cement can maintain an adequate hydrological barrier after decades of CO₂ exposure. On the other hand, cement samples revealed unequivocal evidence for CO₂ interactions at the cement-casing and cement-cap rock interfaces. For the single well investigated, Carey et al. (2007) found that processes (2) and (3) were not important for the observed interaction phenomena, while processes (1), (4) and (6) turned out to be significant. When dealing with old wells, information on construction details is often patchy. Consequently, the well age has been used as a proxy for its integrity, i.e. the probability of well failure. The investigation continued with the PDF constructions focused on the six leakage pathways discussed above and by considering the findings obtained from the SACROC samples, discussed in the following.

6.3.6.1 *Pathway 1: cement-casing interface*

Occurrence of a microannulus at the cement-casing interface is probable due to pressure and thermal stress during operation, raising the possibility that microannulus generation increases with operation time. The leakage effect may be mitigated by carbonate precipitation with respect to a small annulus aperture. Larger apertures may cause significant flow. Due to a lack of corresponding data, an aperture of 5 mm has been approximated as a maximum. For the case study, a cubic relationship between effective permeability and annulus aperture ($k = (\text{aperture})^3/12$) has been adopted (Snow, 1968). In CO2-PENS a PDF referring to the effective permeabilities along the cement-casing interface is used.

6.3.6.2 *Pathway 2: Flow through the cement matrix*

Matrix flow is not considered a significant leakage pathway, due to the very low effective permeability (magnitude of 10^{-9} Darcy) of appropriately placed cement. However, cement permeability can be modified by CO₂ diffusion and interaction. Within the SACROC project, cement permeabilities of 10^{-4} Darcy were measured in old wells, which provides sufficient fluid retardation, considering the relatively large thickness of the well bore cement.

6.3.6.3 *Pathway 3: Flow through pathways created by bulk chemical dissolution of the cement*

Although carbonate brine causes dissolution of cement, typical thicknesses of wellbore cements are likely to prevent significant leakage. This consideration is in accordance with the observations in SACROC. Due to the minor importance of this process, no corresponding PDF is required.

6.3.6.4 *Pathway 4: Flow through fractures in the cement*

Fracturing of wellbore cement is likely due to thermal and mechanical stress associated with well operations. However, CO₂ flow through fractures is considered self limiting due to three phase flow of CO₂ resulting from pressure and temperature decrease during upward migration. Within SACROC, fractures have been observed to be filled with calcium carbonate or hydroxide, indicating an initial fluid flow ultimately terminated by mineral precipitation, leading to the conclusion that no PDF is required to quantify the contribution of this migration process.

6.3.6.5 *Pathway 5: Flow through an open annular region due to inadequate cement placement*

Inadequate cement placement depends on quality assessment and is more likely to be present in older wells. It may be a result of incomplete casing coverage. The SACROC project does not provide further insights in this matter. Viswanathan et al. (2008) propose to apply PDFs exhibiting a bimodal distribution, covering older and newer wells. For simplicity, the wells in the study have been assumed to be properly cemented. Thus, no PDFs have been created.

6.3.6.6 *Pathway 6: Flow at the cement-cap rock interface*

Formation of a porous interface between wellbore cement and cap rock is probable. A tight bond between these two compartments can be impeded by mechanical tension, for instance created by shale swelling. A further circumstance provoking a porous interface is 'wall cake', i.e. non-removed drilling mud and cap rock debris. Fluid migration through the interface is governed by the effective aperture and is related to effective permeability by the cubic equation mentioned above. Leakage through the cement-cap rock interface is considered more probable for older wells. Migrating CO₂ may cause self sealing to a certain extent at moderate flows. In CO2-PENS, a PDF referring to typical cement permeability has been applied.

The limited data available complicates PDF-creation for interface apertures. For CO2-PENS a standard aperture of 3 mm accompanied by a standard deviation of 2 mm has been applied. The CO2-PENS wellbore release module is capable of predicting CO₂ release based on the given wellbore cement effective permeability. Simulations can be conducted in three ways:

1) User specified distribution of leakage rates

If the user has obtained information on leakage by other means than CO2-PENS they can be used as input for further simulations.

2) Finite Element Heat and Mass Transfer (FEHM)

The FEHM-model embedded in CO2-PENS represents a multidimensional multiphase reservoir simulator. This tool supports the user in estimating CO₂ leakage rates relying on detailed numerical simulation of leakage. Application consumes considerable computation time. However, if cement-associated leakage is accompanied by other leakage pathways, application of the FEHM model is required.

3) Calculation of leakage rates by a semi analytical model

With respect to semi analytical modelling, a model developed by Nordbotten et al. (2009), referred to as the 'Princeton Model', has been embedded in CO2-PENS. The advantage lies in the moderate computation time required for calculating reliable leakage rate estimations.

Table 6.5. Key Parameters of the synthetic reservoir used for injection and leakage simulation (according to Viswanathan et al., 2008).

Depth to bottom of sequestration reservoir	3 km
Pressure in sequestration reservoir	30 MPa
Temperature in sequestration reservoir	155 °C
Max injection pressure	45 MPa
Injection duration	50 years
Injection rate	50 kg/s
Simulation duration	50 years
Number of Monte Carlo realizations	1000
Mean of permeable layers porosity (normal distribution)	0.14
Standard deviation of permeable layers porosity (normal distribution)	0.03
Mean of effective aperture in cement (normal distribution)	3 mm
Standard deviation of effective aperture in cement (normal distribution)	2 mm

The case study, based on the synthetic reservoir, encompasses a sequestration target reservoir, impermeable and permeable layers in the saturated zone, the vadose zone and the land surface (Figure 6.9). The scenario further consists of one injection well. Leakage out of the storage reservoir is assumed to occur through eight plugged and abandoned wells. Additionally, 10 shallow wells have been added to the scenario not intersecting the storage reservoir. CO2-PENS relies on numerous data inputs, which may be available from various data base systems. For this purpose tools have been implemented allowing import, selection, pre-processing, and usage of imported data at the system level.

Reservoir permeability and porosity have been assumed similar to the SACROC site. In absence of direct permeability measurements, permeability has been calculated from porosity. The implemented GIS tools have been used to extract necessary information from the SACROC site in order to build a spatial data base.

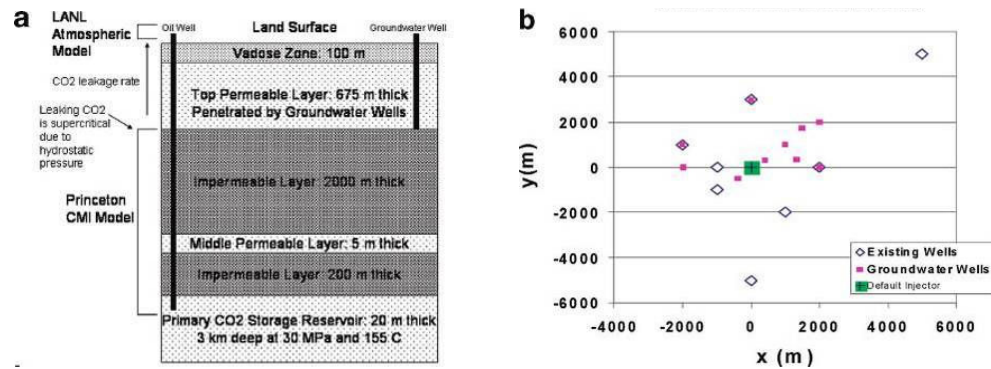

Figure 6.9. (a) Hypothetical reservoir cross section and (b) location of existing deep wellbores and shallow groundwater wells (top view), adopted from Viswanathan (2008).

The key input parameters for the Princeton model are revealed in Table 6.5. Within the area of interest, the individual porosity values were generalized and characterized by standard deviations. For the porosity-PDF, a normal distribution was assumed while permeability was assumed to have a log-normal distribution. The cement fracturing has been conservatively assumed to be considerable. After setting up the permeability-PDFs, 1000 Monte Carlo Simulation runs have been performed to simulate wellbore leakage over a period of 50 years.

The results in terms of leakage rate as a function of aquifer layer and time are depicted in Figure 6.10. Total leakage was quantified as high as 6×10^4 kg CO₂ over 50 years. Compared to the simulated injection of 8×10^{10} kg of CO₂ the leakage rate is way below the committed benchmark of $0.01\% \text{ a}^{-1}$. As expected, leakage to the topmost layer reveals the lowest quantities due to retention by the intermediate layers. Seepage to the surface is additionally moderated by the top permeable layer and the vadose zone. The development of a module enabling comprehensive simulation of the vadose zone is under way (Viswanathan et al., 2008).

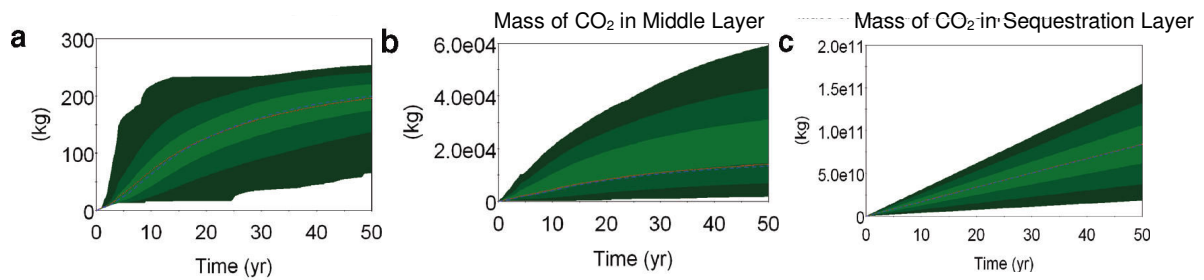

Figure 6.10. Average (dotted line), standard deviation (green) of the accumulation rates of CO₂ in the storage reservoir (a) and in the two shallower reservoirs (b, c) as functions of time. These results are based on 1000 Monte Carlo simulations and cover a simulated period of 50 years (adopted from Viswanathan et al., 2008).

One significant feature of the leakage model is the capability to calculate the spatial extension of a plume, generated in any CO₂ containing aquifer. This information is subsequently processed by CO₂-PENS to evaluate intersection of CO₂ plumes by groundwater wells. The simulation study on the synthetic reservoir revealed that up to 3 out of the 10 shallow wells are impacted by CO₂ after 50 years. The radii of the modelled plumes ranged between 1 and 20 m. Such information can be subsequently processed to evaluate the hydrochemical impact on aquifers. Recently, the geochemical

model PHREEQC has been linked to CO₂-PENS for such purposes. However, this was not considered in the investigation.

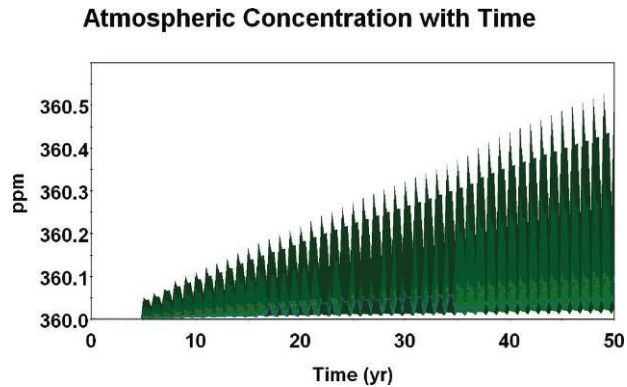

Figure 6.11. The average (dashed line) and standard deviation (green) increase in predicted atmospheric CO₂ concentration due to wellbore leakage obtained from 100 Monte Carlo simulations. CO₂ concentrations include contributions from both, the biosphere and a diffuse leak (adopted from Viswanathan et al. (2008).

Due to the modular architecture of CO₂-PENS, coupling of the well leakage module with the atmospheric model was feasible. To achieve this, a fraction of the leakage rate calculated by the well leakage module was passed to the atmospheric mixing module for every time step. This was constrained by the Princeton model which is not capable of calculating CO₂ migration to the vadose zone, where the fluid is subject to phase transition. Therefore it was assumed that 10% of the leakage rate into the top permeable layer would be subject to seepage to the atmosphere, taking the considerable retention potential of the vadose zone into account. At each time step in the system model, the wellbore module is queried to predict the leakage rate into the top aquifer. This leakage rate is passed back to the system model, which subsequently passes a fraction of 10% of this leakage rate to the atmospheric mixing module. The atmospheric model then processes the seeped CO₂ masses with highly resolved time steps, taking the diurnal near-surface CO₂ concentration variations into account. Once the envisaged vadose zone module is established, estimations can be substituted by model simulations. The simulated atmospheric CO₂ concentrations including the seasonal variations are depicted in Figure 6.11.

The modular structure of CO₂-PENS holds the potential for a comprehensive risk assessment tool with respect to CO₂ storage. It can be used as a screening tool as well as for performance and risk assessment of individual sites, when site-specific information becomes available.

7 Recommended best practice

7.1 Existing wells and future wells

Two general types of wells can be distinguished regarding long-term geological storage of CO₂, i.e. existing wells and future wells (Watson and Bachu, 2007).

Future wells comprise wells directly related to the CO₂ storage operations, such as CO₂ injection or monitoring wells, and wells penetrating or transecting a CO₂ storage reservoir aimed at other structures or deeper reservoirs e.g. for production of hydrocarbons or geothermal energy. These wells can be designed, drilled, completed and abandoned taking into account the preceding CO₂ storage operations, using state-of-the-art materials and techniques. The well section running through the storage reservoir and its caprock should be equipped with corrosion resistant materials using appropriate techniques. Similar practices have been employed over decades in oil and gas industry to adequately deal with sour gas (mainly CO₂ or H₂S) occurrences. Therefore, suitable skills and technology are available to effectively seal and isolate the CO₂ storage reservoir.

In contrast to wells drilled after CO₂ storage activities, existing wells did not benefit from the prescience on the presence of corrosive fluids in the storage reservoir during their design, drilling, completion and/or abandonment phases. Therefore, their configurations may not agree with such purpose. Existing wells can be subdivided in operational wells and abandoned wells.

If necessary, operational wells can usually be adapted to fit injection or abandonment of corrosive fluids. Although costly, such operations can be performed using suitable workover materials and techniques that are currently available in the petroleum industry. In principle techno-economical considerations determine the feasibility of these measures, and therefore, of the storage project. An important advantage over abandoned wells is that operational wells in principle are accessible and need to be plugged during abandonment. Although the design, drilling and completion phases were developed not taking into account CO₂ storage, the crucial abandonment phase can be tailored to specific requirements associated with long-term CO₂ containment. If existing wells were converted for CO₂ injection, these should be tested to ensure their integrity under pressure (Randhol et al., 2007).

The main issue is with previously abandoned wells. These wells are no longer accessible and therefore cannot be improved when needed, without huge costs. As described in the preceding chapters, abandonment practices historically gradually developed to the present high standards. This implies that especially older wells may present problems, and should hence be carefully evaluated when considering their use in CO₂ storage. Oil and gas well abandonment regulations were not enforced simultaneously throughout the world. Moreover, the different regulatory frameworks show diverse levels of stringency (see Chapter 5).

7.2 State-of-the-art well abandonment for corrosive fluids

Recently a lot of effort has been directed at the evaluation of the suitability of conventional materials for long-term containment of CO₂. As a result of uncertainties in reported material degradation rates, proposed abandonment methodologies for present and future decommissioning of CO₂ wells are relatively rigid to ensure safe and

efficient storage of CO₂. A procedure for permanent abandonment of CO₂ wells was proposed by Carlsen and Abdollahi (2007; In: Randhol et al., 2007), recommending the use of specialized cement and casing materials. Similar to oil and gas wells, sealing elements should consist of multiple pressure barriers and prevent cross-flow. Specific attention in the case of CO₂ storage is directed at materials that are chemically inert to wet CO₂ and provide sufficient bond strength. The described methodology can be applied to future wells and existing, operational wells.

The proposed procedure (Figure 7.1) involves pulling out of hole of tubing and packer, followed by placement of a cement plug at the bottom of the well. A specially designed fluid (e.g. polymer, resin or other advanced materials) could be injected into the reservoir to cause intentional clogging of the near-well area in the reservoir to displace the CO₂ and to delay or reduce contact between CO₂ and well materials. In order to avoid potential leakage along cement-casing micro-annuli, then the casing is milled out at the level of the caprock. Subsequently cement can be injected in the perforations and placed along the open hole interval. A cement squeeze job is proposed both at the bottom and top of the caprock, filling and closing any micro-cracks that could have developed during previous operations (Randhol et al., 2007). Emplacement of a cement plug along a milled-out section is also called a ‘pancake plug’. The well then should be filled with a non-corrosive completion fluid. At more shallow depth, if present at the level of a secondary sealing formation, an extra cement barrier is recommended, again placed after removing and milling out of the casing strings. Finally a surface plug is put in place.

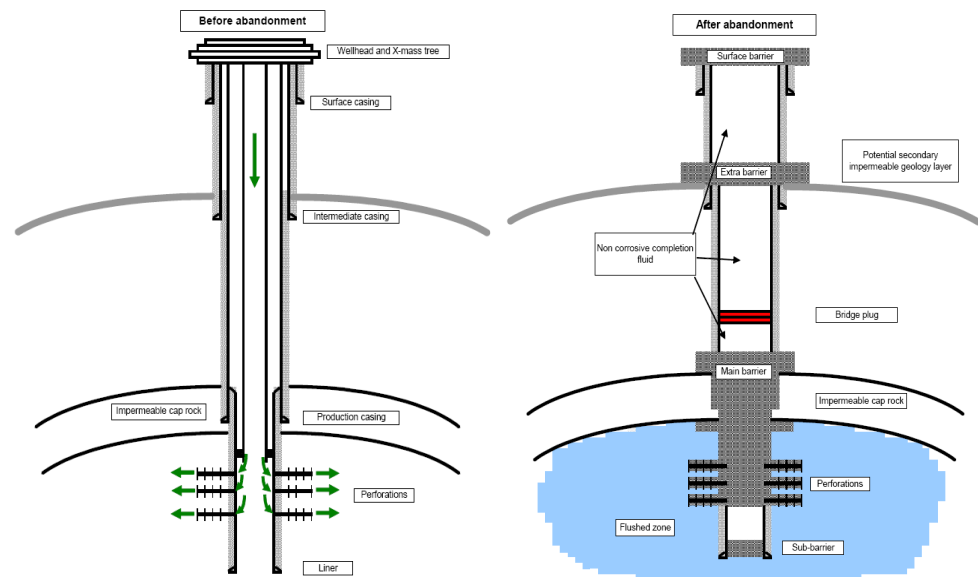

Figure 7.1 CO₂ storage well before (left) and after abandonment (right) according to the methodology described by Carlsen and Abdollahi (2007; In: Randhol et al., 2007).

7.2.1 Advanced materials

Benge (2008) presents an overview of improvements of the isolating capacity of wellbore sealants regarding geological storage of CO₂. Efforts directed at enhancement of the Portland cement-based sealing system have focused on reduction of the cement's permeability after curing and decreasing the concentration of materials that react with

dissolved or wet CO₂. These materials can be applied in drilling, completion, workover and abandonment operations.

7.2.1.1 *Reduced cement permeability and reactivity*

Reducing the cement matrix permeability is a relatively easy measure to decrease the cement's reactivity with CO₂. This can simply be done by reducing the water to cement ratio. However, this also causes an increase of cement density and therefore enhanced hydrostatic pressures in the well. Addition of specialty materials (such as specifically sized particles that fill the cement pore space) provides an alternative method to reduce permeability. This technique also enables modification of the slurry density over a wide range of values to appropriate levels for specific cases. Furthermore, addition of specialty materials at least dilutes the relative amount of reactive species, but can also be tailored such that they protect the reactive species of Portland cement. Barlet-Gouedard et al. (2009) tested Schlumberger's CO₂ resistant cement – EverCRETE – with expansion property, aimed at mitigating the risk of microannulus formation during CO₂ injection. The evaluation shows linear expansion results that can be adequately constrained and optimized by the concentration of expansion agent in the cement at different temperatures. The expansion property has no effects on its mechanical performance after exposure to CO₂.

7.2.1.2 *Non-Portland cements*

As Portland based cements will react with wet CO₂, the application of non-Portland cements (e.g. calcium (sulfo)aluminate-based cements, geopolymeric or alkali aluminosilicate cements, magnesium oxide cements, hydrocarbon-based cements and ceramic-based cements) could be considered for CO₂ storage operations (Benge, 2008). Unfortunately, these materials are incompatible with Portland cements and cross contamination has to be eliminated. Furthermore, the effective density range for non-Portland cements is narrower than for Portland-based cements. Limited availability and higher costs are additional disadvantages of these cements (Benge, 2008).

7.2.1.3 *Self healing cements and swelling packers*

In addition, specialty materials have been developed, such as 'self-healing' cements and in-situ swelling packers (Benge, 2008). Self healing cements contain specific additives designed to react with fluids to clog cracks or debonding annuli and eliminate potential flow. However, swelling technologies so far focused on hydrocarbon swellable materials, rather than additives interacting with CO₂. In addition, developments in slurry design concentrated on slurry design to prevent failure after placement, such as including flexible materials or reducing Young's modulus of the cured cement. Furthermore, swellable packers have been developed to isolate flow in the event of any failure of the cement sheath, rather than to act as initial wellbore seal. Swelling packers are placed on the outside of the casing and are designed to swell when coming into contact with various materials, e.g. hydrocarbons, water or both (Benge, 2008).

7.3 **Managing previously abandoned wells**

As previously abandoned wells generally are not accessible anymore, these cannot easily be re-abandoned. The majority of abandoned wells was not completed and plugged using materials compliant with storage of corrosive fluids. In the preceding chapters conventional techniques and materials as well as its potential reactivity with aqueous CO₂ were extensively described.

7.3.1 *Lessons learnt from field cases*

An excellent example of typical issues that could arise when considering second life applications of fields is provided by the De Lier case in the Netherlands (Section 3.1). The most critical concerns arise from the fact that the performed abandonment measures at the time did not take into account the potential application of the reservoir for CO₂ storage purposes. Furthermore, the case clearly illustrates the important role of historical developments of abandonment regulations. In general wells that have been decommissioned before significant amendments in regulations were enforced, may hold higher risks with respect to CO₂ storage operations. For the De Lier case the fact that the field consists of a stack of reservoirs lead to increased complexity. While CO₂ storage was proposed for the shallowest reservoir, several wells transect this reservoir aiming at deeper strata. At the time of abandonment of these wells the most shallow reservoir was already depleted and no plugs were required at its cap rock level as long as no perforations were present. Finally, some of the wells in need of measures were no longer accessible as a result of urban expansion.

Based on the outcome of the well evaluation, the operator decided that geological storage of CO₂ in the De Lier field was not economically feasible at the time. However, based on the lessons learnt the operator improved its company best practice on well abandonment: although not required by regulations, sites that are earmarked for potential future CO₂ storage are abandoned in a manner compatible to such purpose.

7.3.2 *Risk assessment*

Since the wellbore system, especially at the end of its designed life-cycle, proves to be potentially sensitive to adverse effects associated with CO₂ storage, the current state of the wells involved needs to be confidently assessed when considering CO₂ storage. Special attention should be paid to previously abandoned wells. This involves, first of all, an evaluation of the abandonment configuration. Re-evaluation of wells that were successfully abandoned upon finishing production in the De Lier case evidently showed that securing long-term isolation of stored CO₂ required substantial additional measures (see Section 3.1), predominantly resulting from the fact that the target storage reservoir was transected by various wells that were aimed and abandoned for reservoirs at greater depth. Second, the current state of the materials involved should be examined, extrapolating from data gathered prior to abandonment. If detailed information on, for instance, the quality of the cement sheath is lacking, no decisive conclusions can be drawn on the safety of the well.

In Chapter 6 different methodologies are described that aim to evaluate risks of CO₂ storage projects associated with the well system. The presented approaches were subdivided in qualitative and quantitative risk assessment methods, the latter being classified in deterministic and probabilistic methods. In general qualitative evaluations precede a subsequent quantitative assessment. Qualitative methods are very well suited for making an inventory of all potentially adverse effects on the well system resulting from CO₂ storage operations. While qualitative risk evaluations could provide assistance to arrive at a comprehensive risk assessment, these in themselves lack the possibility to calculate probabilities and impacts connected with the hazards defined. Quantitative methodologies enable predictions of the evolution and performance of the well system.

In general different approaches will be applied for different situations. Operations involving numerous wells benefit the most from grouping of multiple more or less similar wells into classes and using probabilistic risk assessment methodologies.

Quantitative methods employed on storage reservoirs comprising few wells can consist of deterministic approaches. However, even these necessarily comprise probabilistic or statistical elements. Furthermore, it should be noted that impact of leakage and therefore the associated risks are highly dependent on surface environment (e.g. population density, level of urbanization). In addition norms and perception related to geological storage of CO₂ may vary at different locations or regions worldwide.

7.3.3 *Monitoring and remediation*

Monitoring of well integrity for CO₂ storage is part of the entire suite of monitoring techniques that can be employed on a storage site. Most often abandoned wells cannot be inspected or improved, significantly limiting monitoring options. Monitoring of such wells will generally be constrained to general (near-) surface monitoring of the area around these wells. Potential migration of CO₂ through or along (parts of) abandoned wells could be indirectly detected by e.g. monitoring soil gas concentrations and fluxes, air concentrations and fluxes indicating surface seepage, and regular groundwater chemistry measurements (Benson and Myer, 2002). For this purpose (near-)surface measurements, remote sensing techniques or geophysical methods can be used. However, detection of diffuse leaks may be difficult as its signal is within the range of natural CO₂ fluxes (Benson and Myer, 2002). The addition of tracers to the injected CO₂ would facilitate easier detection and discrimination of leakage of the stored gas over natural CO₂. Monitoring strategies are discussed in more detail by e.g. Benson et al. (2002).

In worst-case scenarios of leakage through abandoned wells, they should be re-entered, if physically possible, to be remediated and sealed again below the surface using appropriate materials. Techniques commonly employed in oil and gas industry involve squeeze cementing or the use of expandable tubulars, either on the inside or outside of the casing. If remediation will not eliminate leakage, the reservoir pressure might have to be released to both reduce the pressure gradient that drives migration and reverse potential opening of cracks or annuli. This could be realized by several measures, such as reducing CO₂ injection pressure, abortion of injection or reproducing injected CO₂ to the surface. Alternative options to decrease the reservoir pressure would be peripheral extraction of formation fluids or increasing reservoir capacity by hydrofracturing. Evidently, the latter measure requires great attention to not (further) damage wells or caprock. Obviously it would be beneficial if costly remediation operation could be prevented. A starting point for this is a comprehensive assessment of the wells involved. Furthermore, it would be recommendable to assess potential future applications of depleted reservoirs prior to abandonment, so that the abandonment can be tailored to second-life applications.

8 Conclusions

With respect to the evaluation of long-term integrity of geological CO₂ storage two types of wells can be distinguished, i.e. existing wells and future wells. Future wells can be designed, drilled, completed and abandoned taking into account the preceding CO₂ storage operations, using state-of-the-art materials and techniques that have been developed and employed over decades in oil and gas industry to adequately deal with sour gas (mainly CO₂ or H₂S) occurrences. In contrast, most existing wells were not designed, drilled, completed and/or abandoned taking into account future CO₂ storage purposes. Existing wells comprise operational wells and abandoned wells. Operational wells generally are accessible and can be adapted to fit injection or abandonment of corrosive fluids. Techno-economical considerations determine the feasibility of required workover or abandonment measures. The main issue is with previously abandoned wells that are no longer accessible and therefore cannot be improved when needed, without huge costs.

8.1 Well abandonment techniques and practices

In the oil and gas industry the most common material used for plugging wells is Portland cement. Several different techniques have been developed to emplace the cement in the well, such as the balanced plug method, the dump bailer method and the two-plug method. Of these, the two-plug method provides a maximum of accuracy and a minimum of cement contamination.

The risk of leakage through abandoned wells primarily depends on the regulations toward drilling and abandonment enforced at the time of plugging, of the diligence expressed by the operator during the plugging, and of the materials used in the plugging operation. Inadequate well design, well construction or plugging/abandonment performance may lead to poor isolation. Primary causes of failure are connected to mud contamination as a result of poor mud removal (most common), unstable cement slurries, insufficient slurry volume, and poor job execution.

Abandonment practices historically gradually developed to the present high standards. This implies that especially older wells may present problems, and should hence be carefully evaluated when considering their use in CO₂ storage.

8.2 Well material degradation

It has been established in numerous laboratory studies (e.g. Barlet-Gouédard et al., 2006; Duguid et al., 2006; Kutchko et al., 2007) that cement degradation rates follow a diffusion law. However, results from multiple experimental studies are not univocal and not in full agreement with observed phenomena from field samples. A worst case approach would be the extrapolation of laboratory results from Shen and Pye (1989) obtained at quite severe (temperature) conditions, i.e. 204°C and 69 bar. These experimental results correspond to worst case diffusion-based cement degradation involving CO₂-brine penetration some 12.4 m into the cement over 10,000 years. Taking into account the general results from laboratory studies, rather than this end member value, up to a few meters of cement may be affected over such time span. However, more recent results show substantially lower rates. In general therefore, present-day abandonment plug specifications seem acceptable, although significant differences in abandonment regulations can be observed worldwide with prescribed plug lengths ranging from 15-100 m.

Consequently, the mechanical integrity of the cement plug and the quality of its placement might be of more significance than the chemical degradation of properly placed abandonment plugs (Scherer et al., 2005). The presence or development of fractures or annular pathways in or along the cement strongly affects the permeability of the cement (Shen and Pye, 1989) and will play an important role in leakage mechanisms, potentially significantly enhancing cement degradation (Bennaceur et al., 2004). Migration pathways are most likely to occur at the interfaces between cement and casing or the interface between cap rock and cement. Therefore, most attention should be paid to the potential migration of CO₂ along the different material interfaces. Several mechanisms, both syn- and post-operational, can deteriorate the bond between the cement-steel and/or cement-rock interfaces, such as poor mud removal, cement shrinkage or pressure- or temperature-induced stresses inherent in well operations (Ravi et al., 2002).

This is supported by investigations of downhole cement samples from different field cases maintaining its sealing capacity (Carey et al., 2007; Crow et al., 2008; see Section 3.2.2). Analyses of these samples show that diffusion-controlled degradation of the cement matrix occurred only on a limited scale and does not seem to be a significant hazard to loss of wellbore integrity. In contrast, migration of CO₂ along the cement-steel and cement-formation interfaces was reported by Carey et al. (2007) and Crow et al. (2008) during at least 30 years of exposure to CO₂. In spite of the obvious, but limited flow of CO₂ along the casing-cement interface of the SACROC sample, still no significant corrosion of the casing steel was observed (Carey et al., 2007), possibly as a result of the formation of a partially protecting siderite layer and increased pH values alongside the cement.

8.3 Well abandonment regulations

An overview of available oil well abandonment regulations is presented for a selection of countries and states involved in geological storage of CO₂. Obviously oil and gas well abandonment regulations were not enforced simultaneously throughout the world. Moreover, the different regulatory frameworks show diverse levels of stringency. The evaluated regulations primarily comprise prescriptive requirements for plugging and abandonment of oil and gas wells. It should be noted that also complementary regulations on e.g. labour conditions and environmental impact can significantly influence the effective management of well abandonment.

A general distinction can be observed between European and non-European countries. The main differences lie in the length requirements of the plugs near the deepest casing shoe. While in Europe the length of the cement plug is between 50 to 100 meter, in evaluated non-European regulations the length of the plug is between 30 and 60 meter. When plugging perforated cased sections, the required plug length is in the range of 50 to 100 meters in the considered European countries. The required plug lengths for the studied non-European countries fit in the range of 30 to 60 meters. An exception is formed by the United Kingdom where approximately 30 meter (100 ft) is required in both cases described above, although where possible 150 meter (500 ft) plugs are set. In addition, when mechanical plugs are used, additional cementing is often required. It can be noticed that the required length for additional cementing differs significantly between the countries studied. For instance, in the Netherlands and in China 50 m additional cementing is required, whereas API requires 6 m of cement. Considering the plugs that isolate the permeable zones, the required plug length is again in the range of 50 to 100 meters in most considered countries, both within and outside Europe.

Exceptions are the United Kingdom and Alberta (Canada), where a minimum plug length of 30 meters (or 100 ft) is prescribed.

As most abandoned wells that will play a role in future CO₂ storage projects were abandoned according to present or historical oil well abandonment regulations, the focus of this study lies in these regulatory requirements. However, at present provisions for CO₂ storage are being developed and implemented in many countries. For instance, in Germany, Australia and Norway as well as in the international conventions for marine protection amendments have already been made.

8.4 Risk management methodologies

As most abandoned wells are not easily accessed and, if required, remediated, a comprehensive assessment of risks associated with the wellbores need to be performed when considering geological storage of CO₂. Several risk assessment and management methodologies have been developed over the past years. In general a distinction can be made between qualitative and quantitative methods. In principle, qualitative approaches, such as Quintessa's CO₂ FEP Database and TNO's CASSIF and FEP methodology, are used in the first stages of risk identification, providing means to comprehensively evaluate the system with respect to potential risks. In general a qualitative assessment will precede quantitative evaluations. Quantitative methodologies can be subdivided in probabilistic and deterministic approaches. Different approaches will be applied for different situations. Operations involving numerous wells benefit the most from grouping of multiple more or less similar wells into classes and using probabilistic risk assessment methodologies. Quantitative methods employed on storage reservoirs comprising few wells can consist of deterministic approaches. However, even these necessarily comprise probabilistic or statistical elements. Several quantitative methodologies have been developed such as the Performance and Risk Management methodology (P&RTM) and SimeoTM-Stor from Oxand S.A., Semi-Analytical Model and Monte Carlo Simulation presented by Kavetski et al. (2006) and the CO₂-PENS method. In general, it should be noted that impact of leakage and therefore the associated risks are highly dependent on surface environment (e.g. population density, level of urbanization). In addition norms and perception related to geological storage of CO₂ may vary at different locations or regions worldwide.

8.5 Recommended best practice

Recently a lot of effort has been directed at the evaluation of the suitability of conventional materials for long-term containment of CO₂. Furthermore new technology and materials have been developed. As a result of uncertainties, proposed abandonment methodologies for present and future decommissioning of CO₂ wells are relatively rigid to ensure safe and efficient storage of CO₂. A procedure for permanent abandonment of CO₂ wells was proposed by Carlsen and Abdollahi (2007; In: Randhol et al., 2007), recommending the use of specialized cement and casing materials. However, newly developed materials, techniques and methodologies can only be applied to future wells and existing, operational wells.

In general previously abandoned wells cannot easily be re-abandoned. These wells will form the biggest challenge regarding long-term containment of CO₂. The most critical concerns regarding previously abandoned wells arise from the fact that the performed abandonment measures at the time did not take into account the potential application of the reservoir for CO₂ storage purposes. As a consequence, the majority of abandoned wells was not completed and plugged using design and materials compliant with storage

of corrosive fluids. Furthermore, the time of decommissioning versus historical developments of applying abandonment regulations highly determine the quality and suitability of the abandonment with respect to second-life applications of assets. Finally, many abandoned wells may not be easily accessible without relatively high costs.

Since the wellbore system, especially at the end of its designed life-cycle, proves to be potentially sensitive to adverse effects associated with CO₂ storage, the current state of the wells involved needs to be confidently assessed when considering CO₂ storage. This especially goes for inaccessible wells, requiring comprehensive risk assessment and monitoring efforts. This involves an evaluation of the abandonment configuration as well as an examination of the current state of the materials involved applying appropriate risk assessment methodologies. Monitoring of well integrity for CO₂ storage is part of a broad suite of monitoring techniques that can be employed on a storage site. Most often abandoned wells cannot be inspected or improved, significantly limiting monitoring options to general (near-)surface monitoring of the area around these wells, remote sensing techniques or geophysical methods can be used.

In worst-case scenarios of leakage through abandoned wells, there is a limited amount of options that could be pursued. Wells could be re-entered, if physically possible, to be remediated and sealed again below the surface using appropriate techniques, such as squeeze cementing or expandable tubulars. Alternatively, several measures can be employed to reduce the reservoir pressure in order to both reduce the pressure gradient that drives migration and reverse potential opening of cracks or annuli. Obviously it would be beneficial if costly remediation operation could be prevented. A starting point for this is a comprehensive assessment of the wells involved. Furthermore, it would be recommendable to assess potential future applications of depleted reservoirs prior to abandonment, so that the abandonment can be tailored to second-life applications.

Acknowledgements

This study could not have been performed without the preparedness of many researchers and professionals around the world to share their results and experiences. The following persons in particular are acknowledged for their contributions to this report. Farzad Tahmourpour is thanked for his helpful input on oil well abandonment techniques. The authors also appreciate the assistance of Kumagai Tsukasa on translating Japanese regulations and Michael de Vos on extensive discussions on the Dutch regulatory framework on well abandonment and its implications. Margriet Kuijper and Radboud Bisschop from NAM B.V. are thanked for their discussions and permission to include data on the De Lier case study. The assistance of Richard Metcalfe, H.S. Vishwanatan, Jan Nordbotten and Yvi Le Guen is appreciated regarding reviewing and approving the reproduction of the different risk assessment methodologies. Furthermore, the report benefits from the approval of the American Petroleum Institute to reproduce sections of API Bulletin E3 and API Specification 10. Grant Lintern, Jules Schoenmakers, Tim Davies and several others are thanked for their input on well abandonment practices from their professional experiences. A special thanks to Theresa Watson for her contribution and valuable comments to the report. Finally, Neil Wildgust and Toby Aiken from IEA GHG are thanked for their support during the study.

References

- Australian Government Productivity Commission, 2008, Review of Regulatory Burden on the Upstream Petroleum (Oil and Gas) sector, Productivity Commission Issues Paper
- Bachu, S., 2000. Sequestration of CO₂ in geological media: criteria and approach for site selection in response to climate change. *Energ. Conver. Manag.* 41, 953–970.
- Bachu, S., 2008, Legal and Regulatory Challenges in the Implementation of CO₂ Geological Storage: An Alberta and Canadian Perspective, *International Journal of Greenhouse Gas Control* 2, 259 - 273.
- Bachu, S., Watson, T., 2006. Possible indicators for CO₂ leakage along wells. GHGT-8, Trondheim, Norway.
- Bachu, S., Watson, T., 2008. Review of failures for wells used for CO₂ and acid gas injection in Alberta, Canada. GHGT-9, Washington, USA, November 2008.
- Bachu, S., Bennion, D.B., 2008. Experimental assessment of brine and/or CO₂ leakage through well cements at reservoir conditions. *Int. J. Greenhouse Gas Control* (2008). DOI: 10.1016/j.ijggc.2008.11.002.
- Barclay, I., J. Pellenbarg, F. Tettero, J. Pfeiffer, H. Slater, T. Staal, D. Stiles, G. Tilling & C. Whitney (2002): The beginning of the end: A review of abandonment and decommissioning practices. *Oilfield Review*, winter 2001/2002, Schlumberger, UK.
- Barlet-Gouédard, V., Rimmelé, G., Goffé, B., Porcherie, O., 2007. Well technologies for CO₂ geological storage: CO₂-resistant cement, *Oil and Gas Science and Technology — Rev IFP* 62 (3), 1–12.
- Barlet-Gouédard, V., Rimmelé, G., Goffé, B., Porcherie, O., 2006. Mitigation strategies for the risk of CO₂ migration through wellbores, IADC/SPE Drilling Conference, Miami, USA, February 2006 SPE paper 98924.
- Barlet-Gouédard, V., Rimmelé, G., Porcherie, O., Quisel, N., Desroches, J., 2009. A solution against well cement degradation under CO₂ geological storage environment. *International Journal of Greenhouse Gas Control* 3, pp. 206-216. DOI: 10.1016/j.ijggc.2008.07.005.
- Baud, P., Zhu, W., Wong, T., 2000. Failure mode and weakening effect of water on sandstone, *J. Geophys. Res.*, 105(B7), 16,371–16,389.
- Benge, G., 2008. Improving wellbore seal integrity in CO₂ injection wells. GHGT-9, Washington, USA, November 2008.
- Bennaceur, K., N. Gupta, M. Monea, T.S. Ramakrishnan, T. Randen, S. Sakurai & S. Whittaker (2004): CO₂ capture and storage – A solution within. *Oilfield Review*, autumn 2004, Schlumberger, UK.
- Benson, S.M., Myer, L., 2002. Monitoring to ensure safe and effective geologic sequestration of carbon dioxide. IPCC workshop on carbon dioxide capture and storage.
- Benson, S.M., Overview of Geologic Storage of CO₂, In: *Carbon Dioxide Capture for Storage in Deep Geologic Formations - Results from the CO₂ Capture Project: Geologic Storage of Carbon Dioxide with Monitoring and Verification*, D.C. Thomas, S.M. Benson (eds.), Elsevier.
- Benson, S.M., R. Hepple, J. Apps, C.F. Tsang & M. Lippmann (2002): Lessons learned from natural and industrial analogues for storage of carbon dioxide in deep geological formations. Technical report no. LBNL-51170, Earth Sciences Division, Lawrence Berkeley National Laboratory, Berkeley, California, USA.

- Bonett A., Pafitis, D., 1996 Getting to the root of gas migration, *Oilfield review* 8, (1), 36-49.
- Boukhelifa, L., N. Moroni, S.G. James, S. Le Roy-Delage, M.J. Thiercelin & G. Lemaire (2004): Evaluation of Cement Systems for Oil and Gas Well Zonal Isolation in a Full-Scale Annular Geometry. IADC/SPE Drilling Conference, 2-4 March 2004, Dallas. SPE paper 87195.
- Brnak J., Petrich, B., Konopczynski, M.R., 2006. Application of SmartWell Technology to the SACROC CO₂ EOR Project: A Case Study. SPE paper 10117.
- Bruckdorfer, R.A. (1986): Carbon dioxide corrosion in oilfield cements. SPE Rocky Mountain Regional Meeting, May 19-21 1986, Billings, Montana, SPE-15176.
- Bull, H.J., 1981, Norwegian Offshore Petroleum, The Legal and Administrative Response. Available at <http://www.cenneth.com/sisl/pdf/25-2.pdf>
- Burke, P.A., 1984. "Synopsis: Recent Progress in the Understanding of CO₂ corrosion", in *Advances in CO₂ Corrosion*, Vol. 1, eds. R.H. Hausler, H.P. Goddard, paper no. 3 (Houston, TX: NACE International, 1984).
- Cailly, B., Le Thiez, P., Egermann, P., Audibert, A., Vidal-Gilbert, S., Longaygue, X., 2005. Geological Storage of CO₂: A State-of-the-Art of Injection Processes and Technologies, *Oil & Gas Science and Technology – Rev. IFP*, Vol. 60, No. 3, pp. 517-525
- Calvert, D.G., Smith, D.K., 1999. Issues and Techniques of plugging and abandonment of oil and gas wells. SPE paper 28349.
- Carey, J.W., Svec, R., Grigg, R., Lichtner, P.C., Zhang, J., Crow, W., 2008. Wellbore integrity and CO₂-brine flow along the casing-cement microannulus. GHGT-9, Washington, USA, November 2008.
- Carey, J.W., Wigand, M., Chipera, S., Gabriel, G. W., Pawar, R., Lichtner, P.C., Wehner, S.C., Raines, M.A., Guthrie Jr., G. D., 2007. Analysis and performance of oil well cement with 30 years of CO₂ exposure from the SACROC unit, West Texas, USA, *Internat. J. of Greenhouse Gas Contr.*, 75–85.
- Chang, C.F., Chen, J.W. 2005. Strength and elastic modulus of carbonated concrete, *ACI Mater J*, 102 (5), 315–321.
- Chen, C.F., Lu, M.X., Zhao, G.X., Bai, Z.Q., Yan, M.L., Yang, Y.Q., 2002. CO₂ corrosion for oil tube steel. *Acta Metall. Sin.* 38, p. 770 (in Chinese).
- Chokshi, K.K., 2004. A study of inhibitor-scale interaction in carbon dioxide corrosion of mild steel. Thesis, Ohio University, June 2004.
- Çolak, A., 2006. A new model for the estimation of compressive strength of Portland cement concrete", *Cement and Concrete Research*, 36 (7), 1409-1413
- Collin, F., Cui, Y.-J., Schroeder, Charlier, R., 2002. Mechanical behaviour of Lixhe chalk partly saturated by oil and water: experiment and modeling. *Int. J. Numer. Anal. Methods Geomech.* 26, 897–924.
- Crawshaw, J.P., Frigaard, I., 1999. Cement Plugs: Stability and Failure by Buoyancy-Driven Mechanism. SPE paper 56959.
- Crow, W., Williams, B., Carey, J.W. Celia, M., Gasda, S., 2008. Wellbore integrity analysis of a natural CO₂ producer. GHGT-9, Washington, USA, November 2008.
- Cui, Z.D., S.L. Wu, S.L. Zhu & X.J. Yang, 2006. Study on corrosion properties of pipelines in simulated produced water saturated with supercritical CO₂. *Applied Surface Science* 252, pp. 2368–2374.

- DEA, 2007, A Guide to Hydrocarbon Licenses in Denmark. Available at: www.ens.dk/graphics/UK_Oil_Gas/Licensing_exploration/General_legislation_and_information/Guide_to_HC.pdf
- Department of Energy and Climate Change, 2009, Guidance Notes, Decommissioning of Offshore Oil and Gas Installations and Pipelines under the Petroleum Act 1998, Offshore Decommissioning Unit. Available at https://www.og.berr.gov.uk/regulation/guidance/decomm_guide_v1.doc
- DOGGR, 2006, California Code of regulations, Title 14. Natural Resources, Division 2. Department of Conservation. Available at: <ftp://ftp.consrv.ca.gov/pub/oil/regulations/PRC04.PDF>
- Duguid, A., 2008. An estimate of the time to degrade the cement sheath in a well exposed to carbonated brine. GHGT-9, Washington, USA, November 2008.
- Duguid, A., M. Radonjic, R. Bruant, T. Mandrecki, G. Scherer & M. Celia (2004): The effect of CO₂ sequestration on oil well cements. Proceedings of the 7th International Conference on Greenhouse Gas Control Technologies, 5-9 September 2004, Vancouver.
- Duguid, A., Radonjic, M. and Scherer, G., 2006. The effect of carbonated brine on the interface between well cement and geologic formations under diffusion-controlled conditions, 8th International conference on Greenhouse Gas Control Technologies, Trondheim, Norway, June 19-22.
- Dusseault, M.B., M.N. Gray & P.A. Nawrocki (2000): Why oilwells leak: Cement behavior and long-term consequences. Proceedings of the SPE International Oil and Gas Conference and Exhibition in China, Beijing, China, 7-10 November 2000, paper SPE 64733.
- Dusseault, M.B., Rothenburg, L. 2002. Analysis of deformation measurements for reservoir management. Oil & Gas Sci. and Tech. - Rev. IFP, 57 (5), 539-554
- El-Hassan, H., M. Sultan & A.A. Saeed (2005): Using a flexible, expandable sealant system to prevent microannulus formation in a gas well: a case history. SPE 92361.
- Energy Information Administration (EIA), 2006. Energy Information Sheets: Petroleum Supply Annual 2006. <http://www.eia.doe.gov/neic/infosheets/crudeproduction.html>
- Energy Information Administration (EIA), 2007. U.S. Crude Oil, Natural Gas, and Natural Gas Liquids Reserves 2007 Annual Report
- Englehardt, J., Wilson, M.J., Woody, F., 2001. New Abandonment Technology New Materials and Placement techniques. SPE paper 66496.
- ERCB, 1990, Directive 9: Casing Cementing Minimum Requirements. Available at: <http://www.ercb.ca/docs/Documents/directives/Directive020.pdf>
- ERCB, 2007, Directive 20: Well Abandonment Guide. Available at: <http://www.ercb.ca/docs/Documents/directives/Directive020.pdf>
- ERCB, 2008, Directive 72: Well Abandonment Notification Requirements. Available at: <http://www.ercb.ca/docs/Documents/directives/Directive072.pdf>
- Fang, H., S. Nestic & S. Wang, 2006b. Effects of high salt concentration on general CO₂ corrosion. Master of Science graduate report, Ohio University, Chemical Engineering (Engineering).
- Fang, H., S. Nestic, B. Brown & S. Wang, 2006a. General CO₂ corrosion in high salinity brines. ECS 210th meeting, Abstract 0889.
- Fields, S.A., Martin M.M., 1997. The Plugging Process: Securing Old Gas & Oil Wells for the protection of the Environment. Proceedings: Decommissioning Workshop, September 1997, California, USA.

Gasda, S.E., S. Bachu, and M.A. Celia, 2004. The Potential for CO₂ Leakage from Storage Sites in Geological Media: Analysis of Well Distribution in Mature Sedimentary Basins. *Environ. Geol.*, 46 (6-7), 707-720

Gonzalez R.J., Reeves, S.R., Eslinger, E., Garcia, G. Development and Application of an integrated Clustering/Geostatistical Approach for 3D Reservoir Characterization, SACROC Unit, Permian Basin [Journal]. - 2007. - SPE 111453.

Hettema, M. , Papamichos E., Schutjens, P., 2002. Subsidence delay: field observations and analysis, *Oil and Gas Science and Technology* 57 (5), pp. 443–458.

Huerta, N.J., Bryant, S.L., Strazisar, B.R., Kutchko, B.G., Conrad, L.C., 2008. The influence of confining stress and chemical alteration on conductive pathways within wellbore cement. GHGT-9, Washington, USA, November 2008.

Ide, S.T. Friedmann S. J., Herzog H. J., 2006. CO₂ leakage through existing wells: current technology and regulations. Presented at the 8th International Conference on Greenhouse Gas Control Technologies, Trondheim, Norway, June (2006).

International Panel on Climate Control (IPCC), 2005. IPCC Special Report on Carbon Dioxide Capture and Storage. Prepared by Working Group III of the Intergovernmental Panel on Climate Change [Metz, B., O. Davidson, H. C. de Coninck, M. Loos, and L. A. Meyer (eds.)]. Cambridge University Press, Cambridge, United Kingdom and New York, NY, USA, 442 pp.

ISO (International Organization for Standardization), 2009. ISO/DIS 31000. Risk management -- Principles and guidelines on implementation.

http://www.iso.org/iso/iso_catalogue/catalogue_tc/catalogue_detail.htm?csnumber=43170.

Jacquemet, N.; Pironon, J.; Caroli, E., 2005. A new experimental procedure for simulation of H₂S + CO₂ geological storage. *Oil Gas Sci. Technol.* 60 (1), 196-206.

Johnson, N.L. & M.B. Tomson, 1991. Ferrous carbonate precipitation kinetics and its impact CO₂ corrosion. NACE CORROSION 1991, paper 91.

Kassir, M. K., K. K. Bandyopadhyay, M. Reich, 1993. Thermal Degradation of Concrete in the Temperature Range from Ambient to 315°C (600°F), BNL-52384, Brookhaven National Laboratory, June 1993.

Kavetski, D., J. M. Nordbotten, and M. A. Celia (2006), Analysis of potential CO₂ leakage through abandoned wells using a semi-analytical model, Proceedings of the 16th conference on Computational Methods in Water Resources.

Kinn, S.J., 1999, Regional Environmental Impact Assessment, Experiences from Norwegian Petroleum Activity. Available at: <http://www.nordregio.se/Files/r003juel%20kinn.PDF>

Kutchko, B., B. Strazisar, D. Dzombak, G. Lowry, 2006. Degradation of well cements under geologic sequestration conditions, Wellbore Integrity network Meeting, Princeton, N.J, March 29, 2006.

Kutchko, B.G., Strazisar, B.R., Dzombak, D.A., Lowry, G.V., Thaulow, N., 2007. Degradation of well cement by CO₂ under geological sequestration conditions. *Environ. Sci. Technol.* 2007, 41, 4787-4792.

Kutchko, B.G., Strazisar, B.R., Lowry, G.V., Dzombak, D.A., Thaulow, N., 2008. Rate of CO₂ attack on hydrated Class H well cement under geological sequestration conditions. *Environ. Sci. Technol.* 2008, 42, 6237-6242.

Ladva, H.K.J., B. Craster, T.G.J. Jones, G. Goldsmith & D. Scott (2005): The Cement-to-Formation Interface in Zonal Isolation. IADC/SPE Asia Pacific Drilling Technology Conference Exhibition, 13-15 September 2005, Kuala Lumpur. SPE paper 88016.

- Larkin R., Creel, P. Methodologies and Solutions to remediate Inter-Well Communication Problems on the SACROC CO₂ EOR Project: A case Study [Journal]. - [s.l.] : Society of Petroleum Engineers , 2008. - SPE 113305.
- Le Guen, Y., Le Gouevic, J., Chammas, R., Gerard, B., Poupard O., Van Der Beken, A., Jammes, L. (2008) CO₂ Storage – Managing the Risk Associated With Well Leakage over Long Timescales. SPE Paper 116424.
- Lécolier, E., A. Rivereau, N. Ferrer, A. Audibert & X. Longaygue (2006): Durability of oilwell cement formulations aged in H₂S-containing fluids. IADC/SPE Drilling Conference, February 21-23 2006, Miami, Florida, IADC/SPE-99105.
- Lécolier, E., Ferrer, N., Lamy, F., Bazin, B., Rivereau, A., 2008. Behaviour of permeable steel/cement interface in contact with CO₂-saturated brine. Abstract. GHGT-9, Washington, USA, November 2008.
- Lécolier, E., Rivereau, A., Le Saoût, G., Audibert-Hayet, A., 2007. Durability of hardened Portland cement paste used for oilwell cementing. Oil & Gas Science and Technology – Rev. IFP, Vol. 62, No. 3, pp. 335-345. DOI: 10.2516/ogst:2007028.
- Lin, G., M. Zheng, Z. Bai, & X. Zhao, 2006. Effect of Temperature and Pressure on the Morphology of Carbon Dioxide Corrosion Scales. Corrosion 62, pp. 501-507.
- Liteanu, E., Spiers, C.J., Peach, C.J., 2008. Failure behaviour of wellbore cement in the presence of water and supercritical CO₂. GHGT-9, Washington, USA, November 2008.
- London Protocol, 2006b, Risk assessment and management framework for CO₂ sequestration in sub-seabed geological structures. LC/SG-CO₂ 1/7, annex 3. Available at: http://www.imo.org/includes/blastDataOnly.asp/data_id%3D19064/CO2SEQUESTRATIONRAMF2006.doc
- Mainguy, M., Longuemare. P., Audibert, A., Lecolier, E., 2007. Analyzing the risk of well plug failure after abandonment. Oil & Gas Sci. and Tech. - Rev. IFP, 62 (3), 311-324
- McLaughlin, R.P., 1915, Laws of the State of California: Regulating the Drilling of Petroleum and Gas Wells. Available at: ftp://ftp.consrv.ca.gov/pub/oil/laws/laws_1915.pdf
- METI, 1986, Well Abandonment Standards Japan
- Meyer, J.D., 2007. Summary of Carbon Dioxide Enhanced Oil Recovery (CO₂-EOR) Injection Well Technology. Background report prepared for the American Petroleum Institute. http://www.gwpc.org/e-library/e-library_documents/e-library_documents_co2/API%20CO2%20Report.pdf
- Meyer, V., Houdu, E., Poupard, O., Le Gouevic, J. (2008) Quantitative risk evaluation related to long term CO₂ gas leakage along wells, Proceedings of 9th International Conference on Greenhouse Gas Control Technologies.
- Ministry of Petroleum and Energy, 2008, Facts, The Norwegian Petroleum Sector 2008. Available at http://www.npd.no/NR/rdonlyres/24468CE3-30DC-497F-9E43-501FBC48A131/17867/Facts_2008.pdf
- Nelson, E.B. (ed.),1990. Well Cementing. Schlumberger Educational Services, Sugar Land, TX.
- Nelson, E.B., Guillot, D. (eds.), 2006. Well Cementing, Second Edition. Schlumberger Dowell, Sugar Land, TX.
- Nešić, S., M. Nordsveen, R. Nyborg & A. Stangeland, 2003. A mechanistic model for carbon dioxide corrosion of mild steel in the presence of protective iron carbonate films - Part 2: A numerical experiment. Corrosion 59 (6), pp. 489-497.

- Nicot, J., Saripalli, K.P., Hovorka, S.D. And Lakshminarasimhan, S. (2006a) Leakage Pathways from Potential CO₂ Storage Sites in the Texas Gulf Coast and Implications for Permitting. Fifth annual conference on carbon capture and sequestration DOE/Netl Ale (2006)
- Nicot, J.-P., 2008. A survey of oil and gas wells in the Texas Gulf Coast, USA, and implications for geological sequestration of CO₂. *Environmental Geology*, DOI 10.1007/s00254-008-1444-4.
- Nicot, J., Hovorka, S.D., Knox, P.R. And Naing, T. (2006b) Area of Review: How large is large enough for carbon storage? Bureau of economic Geology, Gulf Coast Carbon Centre, Presentations and Publications 2006
http://www.beg.utexas.edu/enviroq/ty/co2seq/pubs_presentations/UIC_Nicot.pdf
- Nordbotten J. M., Celia, .A., Bachu, S., Dahle, H.K. (2005), Semi-Analytical Solution for CO₂ Leakage through an Abandoned Well , *Environmental Science & Technology*, 39(2), 602-611.
- Nordbotten J. M., D. Kavetski, M. A. Celia, S. Bachu (2009), A semi-analytical model estimating leakage associated with CO₂ storage in large-scale multi-layered geological systems with multiple leaky wells, 43(3), 743-749, *Environmental Science & Technology*, doi:10.1021/es801135v.
- NPD, 2008, website visited February 2009:
http://www.npd.no/English/Emner/Ressursforvaltning/Promoting/whynorway_decommissioning.htm,
- O'Connor, P. E., B. R. Corr, S. Palmer, R. C. Byrd, 2004, Comparative Assessment of Decommissioning Applications of Typical North Sea and Gulf of Mexico, Approaches to Several Categories of Offshore Platforms in the Middle East, Proceedings of The Fourteenth (2004) International Offshore and Polar Engineering Conference Toulon, France, May 23 –28, 2004. Available at http://www.tsboffshore.com/images/Paper_ISOPE_2004.pdf
- Onan, D.D. (1984): Effects of supercritical carbon dioxide on well cements. SPE Permian Basin Oil and Gas Recovery Conference, March 8-9 1984, Midland, Texas, SPE-12593.
- Paine, J.G., Dutton, A.R. And Blum, M.U. (1999). Using airborne geophysics to identify salinization in West Texas: The University of Texas at Austin, Bureau of Economic Geology Report of Investigations No 257
- Palacios, C.A. & J.R. Shadley, 1991. Corrosion, no. 47, p 122.
- Paterson, M.S., Wong, T.-f., 2005. Experimental Rock Deformation - The Brittle Field. 2nd Edition. Springer-Verlag, New York, 348 pp.
- Peach, C.J., 1991. Influence of deformation on the fluid transport properties of salt rocks. In: Ph.D. Thesis Geol. Ultraiectina 77, Universiteit Utrecht.
- Peach, C.J., Spiers. C.J., 1996 Influence of crystal plastic deformation on dilatancy and permeability development in synthetic salt rock. *Tectonophysics*, 256, 101-128.
- Petroleum and Gas Inspectorate Brisbane, 2005, New Safety and Technical Legislative Requirements for the Petroleum and Gas Industries, an overview for Drilling Operators, Industry presentation by Petroleum and Gas Inspectorate Brisbane June 2005. Available at http://www.drillsafe.org.au/Presentations%20Jun%2005/QLD%20Government_John%20Fleming.pdf
- Philippacopoulos, A.J. , Berndt, M.L. 2001. Mechanical property issues for geothermal well cements. *Geotherm. Resour. Council Trans.*, 25, 119-124.
- Preston, C., Monea, M., Jazrawi, W., Brown, K., Whittaker, S., White, D., Law, D., Chalaturnyk, R., Rostron, B. (2005) IEA GHG Weyburn CO₂ monitoring and storage project. *Fuel Processing Technology* (86) 1547-1568.

- Pruess, K., 2005. Numerical Simulations Show Potential for Strong Non-isothermal Effects During Fluid Leakage from a Geologic Disposal Reservoir for CO₂, In: Dynamics of Fluids and Transport in Fractured Rock ,B. Faybishenko, P.A. Witherspoon and J. Gale (eds.), Geophysical Monograph 162, 81–89
- Railroad Commission (RRC) of Texas homepage:
<http://www.rrc.state.tx.us/forms/maps/ogdivisionmap.php>
- Randhol, P., Cerasi, P., 2008. CO₂ injection well integrity. SINTEF Petroleum Research, Report no. 31.6953.00/01/08, 29 January 2009.
- Randhol, P., Valencia, K., Taghipour, A., Akervoll, I., Carlsen, I.M., 2007. Ensuring well integrity in connection with CO₂ injection. SINTEF Petroleum Research, Report no. 31.6920.00/02/07, 27 December, 2007.
- Ravi, K., M. Bosma & O. Gastebled (2002a): Safe and Economic Gas Wells through Cement Design for Life of the Well. SPE Gas Technology Symposium, 30 April - 2 May 2002, Calgary. SPE-75700.
- Ravi, K., M. Bosma & O. Gastebled (2002b): Improve the economics of oil and gas wells by reducing the risk of cement failure. IADC/SPE 74497.
- Reddy, B.R., A. Santra,, D. McMechan, D. Gray, C. Brenneis & R. Dunn (2005): Cement mechanical property measurements under wellbore conditions. SPE 95921.
- RGEI, 1986, Decree no. 86-287: Forages, available at:
<http://www.industrie.gouv.fr/sdsi/dtss/regl/cdrgie/fo2.htm#dec784>
- RGEI, 2000, Decree no. 86-287: Forages FO-2-1P, available at:
<http://www.industrie.gouv.fr/sdsi/dtss/regl/cdrgie/fo.htm>
- Rimmelé, G., Barlet-Gouédard, V., Porcherie, O., Goffé, B., Brunet, F., 2008. Heterogeneous porosity distribution in Portland cement exposed to CO₂-rich fluids. Cement and Concrete Research 38, 1038-1048.
- Risnes, R., Madland, M. V., Hole, M., Kwabiah, N. K., 2005. Water weakening of chalk - Mechanical effects of water-glycol mixtures. Journal of Petroleum Science and Engineering, 48, 21-36
- Rogers, M.J., Dillenbeck, R.L., Boncan, V.G., 2006. Ok, we can't get API cement, what now? SPE 102184.
- Scherer, G.W., M.A. Celia, J.-H. Prévost, S. Bachu, R. Bruant, A. Duguid, R. Fuller, S.E. Gasda, M. Radonjic & W. Vichit-Vadakan (2005): Leakage of CO₂ through abandoned wells: role of corrosion of cement. In: D.C. Thomas & S.M. Benson (eds.): Carbon Dioxide Capture for Storage in Deep Geologic Formations, Vol. 2, pp. 827-848.
- Settari, A., 2002, Reservoir compaction, Society of Petroleum Engineers 76805, 62-69
- Shen, J.C. & D.S. Pye (1989): Effects of CO₂ attack on cement in high-temperature applications. SPE/IADC Drilling Conference, February 28 – March 3 1989, New Orleans, Louisiana, SPE/IADC-18618.
- Sherer, G.W., M.A. Celia, J.-H. Prévost, S. Bachu, R. Bruant, A. Duguid, R. Fuller, S.E. Gasda, M. Radonjic & W. Vichit-Vadakan (2005): Leakage of CO₂ through abandoned wells: role of corrosion of cement. In: D.C. Thomas & S.M. Benson (eds.): Carbon Dioxide Capture for Storage in Deep Geologic Formations, Vol. 2, pp. 827-848.
- Smith, D. K., 1990. Cementing, SPE Monograph vol. 4, Society of Petroleum Engineers, Dallas TX.
- Snow, D. T. (1968) Rock fracture spacings, openings, and porosities. J. Soil Mech. Found. Div. Proc. Amer. Soc. Civil Engrs., 94, 73–91.

SOS, 2007, Texas Administrative Code, Title 16: Economic Regulation, Part 1: Railroad Commission of Texas, Chapter 3: Oil and Gas Division. Available at:

[http://info.sos.state.tx.us/pls/pub/readtac\\$ext.ViewTAC?tac_view=4&ti=16&pt=1&ch=3&rl=Y](http://info.sos.state.tx.us/pls/pub/readtac$ext.ViewTAC?tac_view=4&ti=16&pt=1&ch=3&rl=Y)

Spiers, C.J., Peach, C.J., Brzesowsky, R.H., Schutjens, P.M.T.M., Liezenberg, J.L., Zwart, H.J., 1989. Long-term rheological and transport properties of dry and wet salt rocks. Europ. Comm.-Commis., Nucl. Sci. and Tech. Series EUR 11848 .

Standards Norway, 2004, NORSOK Standard D-010, Well integrity in drilling and well operations. Available at: <http://www.standard.no/PageFiles/1315/D-010r3.pdf>

Stauffer, P.H., Viswanathan, H.S., Pawar, R., Guthrie, G.D., (2009) CO₂-PENS: A System Model for Geologic Sequestration of Carbon Dioxide. Environmental Science and Technology, 43, 565-570.

Stiles, D., 2006. Effects of Long-Term Exposure to Ultrahigh Temperature on the Mechanical Parameters of Cement, SPE 98896, 2006 IADC/SPE Drilling Conference, Miami, Florida, 21-23 February.

Strazisar, B.R., Kutchko, B.G., Huerta, N.J., 2008. Chemical reactions of wellbore cement under CO₂ storage conditions: effects of cement additives. GHGT-9, Washington, USA, November 2008.

The Alaska Administrative Code, 2009, Title 20: Miscellaneous Boards and Commissions, Chapter 25: Alaska Oil and Gas Conservation Commission, Article 2: Abandonment and Plugging. Available at: <http://www.legis.state.ak.us/>. Latest revision: March 2009.

The Office of the Queensland Parliamentary Counsel, Petroleum and Gas (Production and Safety) Act 2004, Reprinted as in force on 5 November 2008, Reprint No. 4A

UKOOA, 1995, UKOOA Guidelines for the Suspension and Abandonment of Wells, Issue No. 2 July 2005

US DOE (U.S. Department of Energy) (2006): Degradation of wellbore cement due to CO₂ injection. R&D Facts 3/2006, US DOE, NETL – National Energy Technology Laboratory, Pittsburgh, Pennsylvania.

Van Gerven, T., D. Van Baelen, V. Dutré & C. Vandecasteele (2004): Influence of carbonation and carbonation methods on leaching of metals from mortars. Cement and Concrete Research 34(1), pp. 149-156.

Van Hunnik, E.W.J., B.F.M. Pots & E.L.J.A. Hendriksen, 1996. The formation of protective FeCO₃ corrosion product layers in CO₂ corrosion. NACE CORROSION 1996, paper 6.

Vignes, B., J. Andreassen, S.A. Tonning, 2006, PSA Well Integrity Survey, Phase 1 summary report. Available at

<http://www.ptil.no/getfile.php/z%20Konvertert/Health,%20safety%20and%20environment/Supervision/Dokumenter/psawellintegritysurveyphase1reportrevision300606en.pdf>

Viswanathan, H.S., Pawar, R., Stauffer, P.H., Kaszuba, J.P., Carey, J.W., Olsen, S.C., Keating, G.N., Kavetski, D., Guthrie, G.D. (2008) Development of a Hybrid Process and System Model for the Assessment of Wellbore Leakage at a Geologic CO₂ Sequestration site. Environmental Science and Technology, 42, 7280-7286.

Watson, T., L., Bachu, S., 2007. Evaluation of the Potential for Gas and CO₂ Leakage Along Wellbores. SPE paper 106817, synopsis, J Petrol Technol 59 (7), 78–79.

Watson, T.L., Bachu, S. (2008) Identification of Wells with high CO₂-leakage potential in mature oil fields developed for CO₂-enhanced recovery. SPE paper 112924

Wawersik, W.R., Rudnicki, J.W., Dove, P., Harris, J., Logan, J.M., Pyrak-Nolte, L., Orr, F.M., Ortoleva, P.J., Richter, F., Warpinski, N.R., Wilson, J.L., Wong, T.F., 2001. Terrestrial sequestration of CO₂: An assessment of research needs. *Advances in Geophysics* 43, 97-177.

WBIN4 (2008): Personal communication at the 4th IEA-GHG Well Bore Integrity Network Meeting, March 17-19 2008, Paris, France.

Wong, T.F., David, C., Zhu, W., 1997. The Transition from Brittle Faulting to Cataclastic Flow in Porous Sandstones: Mechanical Deformation. *J. Geophys. Res.*, 102, 3009-3025.

Wu, S.L., Z.D. Cui, G.X. Zhao, M.L. Yan, S.L. Zhu & X.J. Yang, 2004. EIS study of the surface film on the surface of carbon steel from supercritical carbon dioxide corrosion. *Applied Surface Science* 228, pp. 17–25.

Xiao, Y. & S. Nešić, 2005. A Stochastic Prediction Model of Localized CO₂. *NACE CORROSION* 2005, paper 05075.

Zhu, W., Wong, T.F., 1997. Shear-Enhanced Compaction in Sandstone under Nominally Dry and Water-Saturated Conditions. *Int. J. Rock Mech. Min. Sci.*, 34, 3/4, 364.

Websites

- [1] <http://www.ens.dk/sw11492.asp>, Danish Energy Agency (DEA) website visited February 2009.
- [2] <http://www.industrie.gouv.fr/energie/petrole/beph-ang/beph-publicat-ang.htm>, BEPH website visited March 2009.
- [3] http://www.industrie.gouv.fr/cgi-bin/industrie/frame23e_loc.pl?bandeau=/energie/anglais/be_us.htm&gauche=/energie/anglais/me_us.htm&droite=/energie/anglais/accueil.htm, BEPH website visited March 2009.
- [4] http://cdl.niedersachsen.de/blob/images/C39688480_L20.pdf, website visited February 2009
- [5] <http://www2.gtz.de/uvp/publika/English/vol213.htm#3.%20Notes%20on%20the%20analysis%20and%20evaluation%20of%20environmental%20impacts>, GTZ website visited February 2009
- [6] <http://www.standard.no>, website visited January 2009
- [7] <http://www.hmrc.gov.uk/manuals/otmanual/OT00040.htm>, <http://www.dbd-data.co.uk/bb1999/book.htm>, website visited January 2009
- [8] <http://energy.ihs.com/Products/Ukwelldata/>, website visited January 2009
- [9] <http://www.dpi.vic.gov.au/DPI/nrenmp.nsf/LinkView/E1969D9710F16DE2CA256EC8000B159856D4D5E9AEF563E84A256A800011E5D6>, website visited February 2009
- [10] <http://www.nopsa.gov.au>, website visited March 2009
- [11] [http://www.dmp.wa.gov.au/documents/schedule_onshore_PGERA67\(1\).pdf](http://www.dmp.wa.gov.au/documents/schedule_onshore_PGERA67(1).pdf), website visited March 2009
- [12] <http://www.legislation.qld.gov.au/LEGISLTN/CURRENT/P/PetrolmGasA04.pdf>, website visited March 2009
- [13] <http://www.legislation.qld.gov.au/LEGISLTN/CURRENT/P/PetrolmGasR04.pdf>, website visited March 2009
- [14] <http://www.ercb.ca>, ERCB website visited March 2009.
- [15] <http://www.trailcanada.com/images/map-canada.jpg>, website visited March 2009.
- [16] <http://www.winwin.redcome.com/servlet/Folder?node=16575&language=0>, website visited January 2009
- [17] <http://winwin.redcome.com/servlet/Report?Node=17306>, website visited January 2009
- [18] <http://www.meti.go.jp/english/index.html>, METI website visited March 2009.
- [19] <http://www.adem.alabama.gov/LandDivision/Guidance/wellaban.doc>, website visited March 2009.
- [20] http://www.epa.gov/safewater/uic/pdfs/prefr_uic_co2rule.pdf, website visited December 2008
- [21] <http://www.ccsreg.org/interimreport/>, website visited December 2008

- [22] <http://www.epa.gov>, website visited March 2009
- [23] <http://www.epa.gov/ogwdw/uic/primacy.html>, website visited December 2008
- [24] <http://www.aogcc.alaska.org>, website visited February 2009
- [25] <http://www.sos.state.tx.us/tac/index.shtml>, website visited March 2009
- [26] <http://www.rrc.state.tx.us/>, website visited March 2009
- [27] <http://www.imo.org>, website visited January 2009
- [28] <http://www.iea.org> / www.OSPAR.org, website visited January 2009

Well abandonment regulations

Appendix to Well Abandonment Review for CO₂ storage (WellARC)

Appendix A	Denmark	2
Appendix B	France	4
Appendix C	Norway	6
C.1	Material selection.....	6
C.2	NORSOK Standard	9
Appendix D	The Netherlands	12
D.1	Relevant articles of the Mining Legislation	12
D.2	Relevant articles of the Working Conditions Regulation.....	18
Appendix E	United Kingdom	20
Appendix F	Australia	26
F.1	Western Australia.....	26
F.2	Queensland.....	27
Appendix G	Alberta, Canada	30
G.1	Open-hole abandonment requirements	30
G.2	Cased-hole abandonment requirements	32
G.3	Removing Casing and Setting a Cement Plug	35
Appendix H	China	36
Appendix I	Japan	38
Appendix J	United States of America	40
J.1	US EPA.....	40
J.2	API	42
J.3	Alaska	43
J.4	California	46
J.5	Texas.....	48

Appendix A Denmark

Guidelines for Well Abandonment

“A Guide to Hydrocarbon Licences in Denmark” (DEA, 2007) contains the section “Guidelines for Drilling - Exploration” which was published in 1988 and revised in 2005. The latter section contains guidelines for well abandonment. This appendix presents an overview of these guidelines¹:

1. Normally, an exploration well shall be abandoned permanently when drilling operations as well as relevant logging and test production have been carried out. Under special circumstances the DEA may permit a well to be abandoned temporarily without permanent plugging. To obtain such permission the Licensee must submit an application indicating how and when the well is to be abandoned permanently or operations will be resumed. Furthermore, the application must describe the responsibility and supervision situation during the temporary abandonment.
2. Application for permission to stop operations and to plug (permanently or temporarily) and abandon a well, shall together with a copy of essential logs and other relevant documentation material, if any, be available to the DEA at least 24 hours before estimated commencement of the actual abandonment activities. In the application the Licensee shall give the reasons for the planned plugging and specify how the plugging will take place and how the plugs will be checked. The well site condition after the abandonment and procedures for verification of this must be stated.
3. In cases where the well is uncased opposite permeable zones, plugging shall be carried out so that there can be no flow of fluid through the hole (normally by cementing at least 50 m below and above the individual zones).
4. Where there is an open hole below the deepest casing, a cement plug shall be placed in such a manner that it extends at least 50 m above and below the casing shoe. The top of the cement plug shall be located by load testing. Where the condition of the formation makes cementing difficult, a mechanical plug may be positioned in the casing, within 50 m from the shoe as an alternative to the cement plug below the shoe. In addition, a cement plug, at least 50 m long shall be placed on top of this plug. The performed plugging of the open hole section shall be pressure tested for sufficient time and with enough differential pressure to detect a possible leak or mechanical failure of the plug.
5. Perforated zones must be plugged with cement so that no fluid flow to or from the well is possible. Where possible perforated intervals shall be isolated with cement plugs through the individual perforated zones and with 50 m long cement plugs below the lowermost perforation and above the uppermost perforation. Alternatively the perforated zones can be isolated by a combination of a mechanical plug squeeze cementing of the perforations and cement plugging above the mechanical plug.
6. If a liner has been used, a cement plug shall be placed in such a manner that the plug extends 50 m above and below the point of suspension. Alternatively a mechanical plug followed by a 50 m long cement plug can be set just above the liner hanger. The top of the plug shall be located by load testing and the plug shall be pressure tested as specified in item 4.
7. In the innermost casing a cement plug must be placed from the shoe depth of the previous casing and 100 m up.
8. It must be ensured that no communication from down hole formation to the sea-bed/surface via any casing annulus is possible.
9. A cement plug, at least 100 m long, shall be placed near the surface.
10. The total weight of the cement plugs in the well and the weight of the fluid between the plugs shall ensure that as a minimum the system is in balance with any pressure which may develop in the borehole.

¹ DISCLAIMER: The English version of this document is an unofficial translation. In case of discrepancy, the original Danish text shall prevail.

11. When a well is abandoned the original state of the well site shall be re-established. Reasonable departure from this requirement may be approved by the DEA (approval by other authorities may also be necessary). When abandoning a well, the condition of the well site shall be verified. Obtained documentation shall be submitted to the DEA.

Appendix B France

This appendix contains the text from Article 49, named 'Definitive closure of wells'. Article 49² (part of Decree no. 2000-278 (RGIE, 2000)) states that the steps to be taken to abandon a well should be defined in the drilling program. The final closure is carried out by the operator, and must be reported to the Regional Director of the Industry, Research and Environment at least two months before the date of completion. The operator may decide to use the drilling rig in the abandonment process in case the well turns out to be unproductive or for any other reason. Also this process must be reported to the Regional Director. Closure activities can only start when the Regional Director has given his agreement.

The well abandonment operations should isolate permeable layers. The entire drilled section should be taken into account, unless it is not possible to remove the completion. The abandonment operations must be performed such that the permeable layers will remain permeable. In addition, no mixing of fluid between different permeable layers is allowed to occur. To separate permeable layers, only materials are allowed to be used that do not degrade over time. These isolations should be placed such that:

1. Two subsequent permeable layers are isolated, or
2. Other levels are isolated, if incontrollable flows between intermediate layers are acceptable.

Barriers of 50 m should be placed if:

1. A casing is present, or
2. No casing is present and the well is not subject to cave effects.

Barriers of 100 m should be placed:

1. in annuli, or
2. in the spacing between the outer casing and the formation, or
3. if no casing is present and the well is subject to cave effects, or
4. if the borehole is strongly deviated, or
5. in high loss-zones.

If the impermeable layer between two permeable layers is of insufficient height to put a barrier of sufficient length, it is required to:

1. Put a barrier in between the permeable layers, of the maximum length possible, and
2. Put a barrier of sufficient length above the upper permeable layer and below the lowest permeable layer involved.

For isolation close to the surface or the seabed, it is required to put a plug of twice the required length. It is allowed to put this barrier in one piece or in two barriers of standard length. In the last case it is required to follow the isolation rules for permeable layers, as described earlier. The upper barrier should then be as close as possible to the surface or the seabed (see Figure 1).

Finally, all elements should be removed from the seabed that where necessary for drilling. In addition, the casing and its filling needs to be cut at seafloor level.

² DISCLAIMER: The English version of this document is an unofficial translation. In case of discrepancy, the original French text shall prevail.

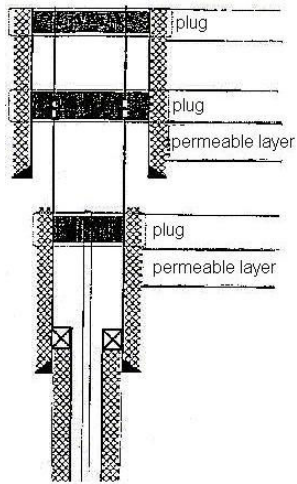

Figure 1 Example of well abandonment for exploitation wells, adapted from RGEI (2000). The upper plug should be as close as possible to the surface or seabed.

Appendix C Norway

This appendix presents the NORSOK Standard D-010 (Standards Norway, 2004). Three tables give an overview of the requirements which are set by the NORSOK Standard regarding well abandonment. It concerns standards for the casing, casing cement and cement plug. In addition, the original NORSOK Standard on permanent well abandonment is presented.

C.1 Material selection

The NORSOK Standard D-010 requires that the permanent barriers for abandoned wells are impermeable, have long term integrity, are non-shrinking, ductile and resistant to different substances and have sufficient bonding to the casing. The following tables give an overview of the requirements which are set by the NORSOK Standard. The references can be found in Standards Norway (2004).

Table 1 – Casing (Originally Table 2 (Standards Norway, 2004)).

Features	Acceptance criteria	References
A. Description	This element consists of casing/liner and/or tubing in case tubing is used for through tubing drilling and completion operations.	
B. Function	The purpose of casing/liner is to provide a physical hindrance to uncontrolled flow of formation fluid or injected fluid between the bore and the back-side of the casing.	
C. Design construction selection	<ol style="list-style-type: none"> 1. Casing-/liner strings, including connections shall be designed to withstand all pressures and loads that can be expected during the lifetime of the well including design factors. 2. Minimum acceptable design factors shall be defined for each load type. Estimated effects of temperature, corrosion and wear shall be included in the design factors. 3. Dimensioning load cases with regards to burst, collapse and tension/compression shall be defined and documented. 4. Casing design can be based on deterministic, probabilistic or other acceptable models. 	ISO 1960 API Bull 5C3 API Bull 5C2
D. Initial test and verification	<ol style="list-style-type: none"> 1. Casing/liner shall be leak tested to maximum anticipated differential pressure. 2. Casing/liner that has been drilled through after initial leak test shall be retested during completion activities. 	
E. Use	<ol style="list-style-type: none"> 1. Casing/liner should be stored and handled to prevent damage to pipe body and connections prior to installation. 	ISO10405 API Bull 5C2
F. Monitoring	<ol style="list-style-type: none"> 1. The A annulus shall be continuously monitored for pressure anomalies. B annulus should be monitored if applicable based on well completion and the type of well. 2. If wear conditions exceed the assumptions from the casing-/liner design, indirect or direct wear assessment should be applied (e.g. collection of metal shavings by use of ditch magnets and wear logs). 	
G. Impairment	<ol style="list-style-type: none"> 1. Leaking casing/liner. 2. Unable to leak test. 3. Unable to monitor annulus pressure. 4. Unable to monitor or control/assess casing wear. 	

Table 2 – Casing cement (Originally Table 22 (Standards Norway, 2004))

Features	Acceptance criteria	References
A. Description	This element consists of cement in solid state located in the annulus between the casing/liner and the formation.	
B. Function	The purpose of the element is to provide a continuous, permanent and impermeable hydraulic seal along hole in the casing annulus or between casing strings, to prevent flow of formation fluids, resist pressures from above or below, and support casing or liner strings structurally.	
C. Design, construction and selection	<ol style="list-style-type: none"> 1. A design and installation specification (cementing programme) shall be issued for each primary casing cementing job. 2. The in-situ compressive strength of the cement shall be higher than the estimated formation strength of the cemented formation. 3. Cement slurries that will be exposed to permeable and abnormally pressured hydrocarbon bearing zones should be designed to prevent gas migration, when the cement sets. 4. The cement placement technique applied should ensure a job that meets requirements whilst at the same time imposing minimum overbalance on weak formations. ECD and the risk of lost returns during cementing shall be assessed and mitigated. 5. Cement height in casing annulus (TOC): <ol style="list-style-type: none"> a. General: Shall be 100 m above a casing shoe, where the cement column in consecutive operations is pressure tested/the casing shoe is drilled out. b. Conductor: No requirement as this is not defined as a barrier element. c. Surface casing: Shall be defined based on lead conditions from wellhead equipment and operations. TOC should be inside the conductor shoe, or to surface/seabed if no conductor is installed. d. Casing through hydrocarbon bearing formations: Shall be defined based on requirements for zonal isolation. Cement should cover potential cross-flow interval between different reservoir zones. For cemented casing strings which are not drilled out, the height above a point of potential inflow/leakage point/permeable formation with hydrocarbons, shall be 200 m, or to previous casing shoe, whichever is less. 6. Temperature exposure, cyclic or development over time, shall not lead to reduction in strength. 7. Requirements to achieve the along hole pressure integrity in slant wells to be identified. 	ISO 10426-1 Class 'G'
D. Initial verification	<ol style="list-style-type: none"> 1. It shall be pressure tested if the casing shoe is drilled out. Note, in cases where this may break down formation, the verification may be through exposing the cement column for differential pressure from fluid column above cement in annulus. In the latter case the pressure integrity acceptance criteria and verification requirements shall be defined. 2. The verification requirements for having obtained the minimum cement height shall be described, which can be: <ol style="list-style-type: none"> a. verification by logs (cement bond, temperature, LWD sonic) or 	

	<p>b. estimation on the basis of records from the cement operation (volumes pumped, returns during cementing, etc.).</p> <p>3. The strength development of the cement slurry shall be verified through observation of representative surface samples from the mixing.</p>	
E. Use	None	
F. Monitoring	<p>1. The annuli pressure above the cement barrier shall be monitored regularly when access to this annulus exists.</p> <p>2. Surface casing by conductor annulus outlet to be visually observed regularly.</p>	WBEAC for “wellhead”
G. Impairment	<p>Non-compliance with any of the above mentioned requirements and the following.</p> <p>Pressure build-up in annulus as a result of e.g. micro-annulus, channelling in the cement column, etc.</p>	

Table 3 – Cement plug (Originally Table 24 (Standards Norway, 2004))

Features	Acceptance criteria	References
A. Description	This element consists of cement in solid state that forms a plug in the wellbore.	
B. Function	The purpose of the plug is to prevent flow of formation fluids inside a wellbore between formation zones and/or to surface/seabed.	
C. Design, construction and selection	<ol style="list-style-type: none"> 1. A design and installation specification (cementing program) shall be issued for each cement plug installation. 2. The in-situ compressive cement strength shall be higher than the estimated formation strength at the depth where plug is installed. 3. Cement slurries that will be exposed to permeable and abnormally pressured hydrocarbon bearing zones should be designed to prevent gas migration, when the cement sets. 4. Permanent cement plugs should be designed for minimal strength reduction and no shrinkage caused by thermal exposure and cyclic loading. 5. It shall be designed for the highest differential pressure and highest downhole temperature expected, inclusive installation and test loads. 6. A minimum cement batch volume shall be defined for the plug in order that homogenous slurry can be made, to account for contamination on surface, downhole and whilst spotting downhole. 7. The firm plug length shall be 100 mMD. It shall extend minimum 50 mMD above and source of outflow/leakage point. A plug in transition form open hole to casing should extend at least 50 mMD below casing shoe. If it is set inside casing and with a mechanical plug as a foundation, the minimum length shall be 50 mMD. A casing/liner with shoe installed in permeable formations should have a 25 mMD shoe track plug. 	API Standard 10A Class ‘G’
D. Initial verification	<ol style="list-style-type: none"> 1. Cased hole plugs should be tested either in the direction of flow or from above. 2. The strength development of the cement slurry should be verified through observation of representative surface samples from the mixing. 3. The plug installation shall be verified through documentation of job performance; records of cement operation (volumes pumped, 	

	<p>returns during cementing, etc.).</p> <p>4. Its position shall be verified, by means of:</p> <table border="1"> <thead> <tr> <th>Plug type</th> <th>Verification</th> </tr> </thead> <tbody> <tr> <td>Open hole</td> <td>Tagging, or measure to confirm depth of firm plug.</td> </tr> <tr> <td>Cased hole</td> <td> Tagging, or measure to confirm depth of firm plug Pressure test, which shall be 7000 kPa (~1000 psi) above estimated formation strength below casing/potential leak path, or 3500 kPa (~500 psi) for surface casing plugs, and not exceed casing pressure test, less casing wear factor which ever is lower (but never lower than leak off/fracture pressure). If a mechanical plug is used as a foundation for the cement plug and this is tagged and pressure tested the cement plug does not have to be verified. </td> </tr> </tbody> </table>	Plug type	Verification	Open hole	Tagging, or measure to confirm depth of firm plug.	Cased hole	Tagging, or measure to confirm depth of firm plug Pressure test, which shall be 7000 kPa (~1000 psi) above estimated formation strength below casing/potential leak path, or 3500 kPa (~500 psi) for surface casing plugs, and not exceed casing pressure test, less casing wear factor which ever is lower (but never lower than leak off/fracture pressure). If a mechanical plug is used as a foundation for the cement plug and this is tagged and pressure tested the cement plug does not have to be verified.	
Plug type	Verification							
Open hole	Tagging, or measure to confirm depth of firm plug.							
Cased hole	Tagging, or measure to confirm depth of firm plug Pressure test, which shall be 7000 kPa (~1000 psi) above estimated formation strength below casing/potential leak path, or 3500 kPa (~500 psi) for surface casing plugs, and not exceed casing pressure test, less casing wear factor which ever is lower (but never lower than leak off/fracture pressure). If a mechanical plug is used as a foundation for the cement plug and this is tagged and pressure tested the cement plug does not have to be verified.							
E. Use	Ageing test may be required to document log term integrity.							
F. Monitoring	For temporary suspended wells: The fluid level/pressure above the shallowest set plug shall be monitored regularly when access to the bore exists.							
G. Impairment	Non-compliance with above mentioned requirements and the following: Loss or gain in fluid column above plug. Pressure build-up in a conduit which should be protected by the plug.							

C.2 NORSOK Standard

The original text in the NORSOK Standard on permanent abandonment, which is based on the previous tables, is as follows (Standards Norway, 2004):

Permanent abandonment

Permanently plugged wells shall be abandoned with an eternal perspective, i.e. for the purpose of evaluating the effect on the well barriers installed after any foreseeable chemical and geological process has taken place.

There shall be at least one well barrier between surface and a potential source of inflow, unless it is a reservoir (contains hydrocarbons and/ or has a flow potential) where two well barriers are required.

When plugging a reservoir, due attention should be paid to the possibilities to access this section of the well (in case of collapse, etc) and successfully install a specific well barrier element.

The last open hole section of a wellbore shall not be abandoned permanently without installing a permanent well barrier, regardless of pressure or flow potential. The complete borehole shall be isolated.

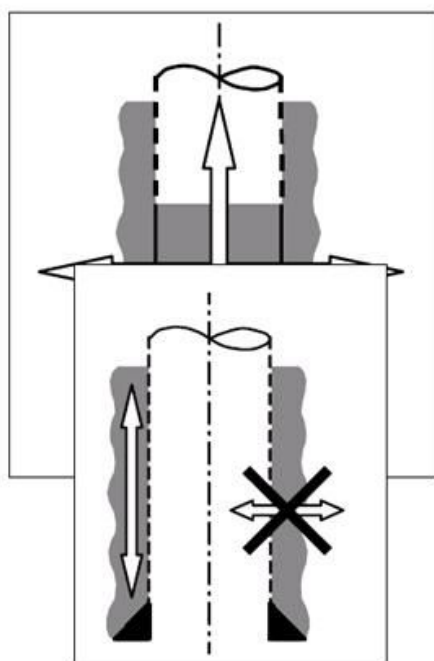

Figure 2 Pressure integrity

Permanent well barriers

Permanent well barriers shall extend across the full cross section of the well, include all annuli and seal both vertically and horizontally (Figure 2). Hence, a well barrier element set inside a casing, as part of a permanent well barrier, shall be located in a depth interval where there is a well barrier element with verified quality in all annuli.

A permanent well barrier should have the following properties:

- impermeable,
- long term integrity,
- non shrinking,
- ductile, – non brittle – able to withstand mechanical loads/ impact,
- resistance to different chemicals/ substances (H_2S , CO_2 and hydrocarbons),
- wetting, to ensure bonding to steel.

Additional requirements

- Steel tubular is not an acceptable permanent well barrier element unless it is supported by cement or a plugging material, with similar functional properties as listed above (inside and outside).
- Elastomeric seals used as sealing components in well barrier elements are not acceptable for permanent well barriers.
- The presence and pressure integrity of casing cement shall be verified to assess the along hole pressure integrity of this well barrier element. The cement in annulus will not qualify as a well barrier element across the well (see Figure 2).
- Open hole cement plugs can be used as a well barrier between reservoirs. It should, as far as practicably possible, also be used as a primary well barrier, see WBEAC in Table 24.
- If there is any doubt as to the top of the cement in the casing annulus and whether it complies with the requirements (see Table 2) the casing should be perforated and cement circulated or squeezed into the annulus to achieve an acceptable annulus seal. An alternative is to cut, or mill a window in, the casing and place a cement plug on top of the cut and across the wellbore.

- Cement in the liner lap, which has not been leak tested from above (before a possible liner top packer has been set) shall not be regarded a permanent well barrier element.
- Removal of downhole equipment is not required as long as the integrity of the well barriers is achieved.
- Control cables and lines shall be removed from areas where permanent well barriers are installed, since they may create vertical leak paths through the well barrier.
- When well completion tubulars are left in hole and permanent cement plugs are installed through and around the tubular, reliable methods to verify top of cement inside the tubular and in the tubular annulus shall be established.

Special requirements

Multiple reservoir zones/perforations located within the same pressure regime, isolated with a well barrier in between, can be regarded as one reservoir for which a primary and secondary well barrier shall be installed (see Figure 3).

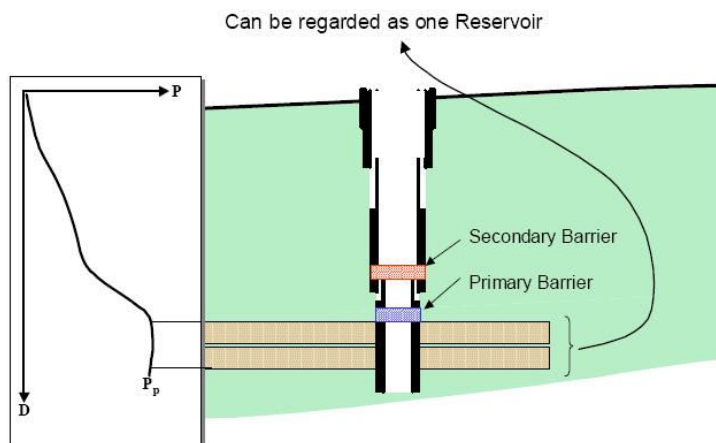

Figure 3 Special requirements

Appendix D The Netherlands

This appendix presents relevant articles of the Mining Legislation and of the Working Conditions Regulation with respect to the abandonment of boreholes and wells.

D.1 Relevant articles of the Mining Legislation³

D.1.1 Mining Act

Article 49

1. By or by virtue of an order in council, rules may be set in respect of :
 - a. the exploration for minerals or terrestrial heat;
 - b. the production of minerals or terrestrial heat;
 - c. the storage of substances;
 - d. the conduct of an exploratory survey;
 - e. drill holes, other than those for the exploration for or production of minerals or terrestrial heat or for the storage of substances, more than 500 metres beneath the surface of the earth;
 - f. pipelines and cables that are being used for the purpose of the exploration for or the production of minerals or terrestrial heat, or for the storage of substances.
2. The rules referred to in Article 49.1 may be set for the purpose of:
 - a. systematic management of deposits of minerals, terrestrial heat and other natural resources;
 - b. the protection of safety;**
 - c. the protection of the environment;**
 - d. the limitation of damage as a result of soil movement.
3. The rules referred to in Article 49.1 may also be set, insofar as the activities referred to in
4. Article 49.1 take place on or in or the territorial sea for the purpose of:
 - a. shipping, the defence of the realm, fishery, the maintenance of the living riches of the sea, pure scientific research, the laying and maintenance of subsea cables and pipelines;
 - b. the protection of historical, archaeological and other scientific finds.

D.1.2 Mining Decree

Section 1.1. Definitions

Article 1

In this Decree and the provisions based thereon, the terms below shall be defined as follows:

- b. damage: damage to the interests referred to in Articles 49.2 and 49.3 of the Mijnbouwwet;
- e. safety: the safety of persons and the protection of goods, in so far as no rules have been prescribed in this area by or by virtue of the Arbeidsomstandighedenwet 1988.

Section 5.1.2. Rules on the use of mining works

Article 37

³ DISCLAIMER

This is an unofficial translation into English of the official Dutch Legislation. This translation is intended only as informational support. Only the texts published in the Dutch Official 'Staatsblad' are authentic.

1. The operator shall see to it that the system of care as meant in Article 2.42e of the Working Conditions Decree and the document (**the safety case**) meant in Article 2.42f of that Decree, also cover **safety** issues.

Part 5.3. Boreholes
Section 5.3.1. General

Article 67

1. When constructing, using, maintaining, repairing and decommissioning a borehole, measures shall be taken to prevent damage.
2. The construction, maintenance, repair and abandonment of a borehole shall take place under the responsibility and in the presence of the operator.

Article 68

The activities as referred to in Article 67.1 shall only be performed if the substances in question from formations are being controlled and contained.

Article 69

1. A borehole shall be fitted with suitable casing.
2. Each series of casing as referred to in Article 69.1 shall be cemented over a sufficient distance and then tested for reliability.
3. The first series of casing shall be properly sealed immediately after it has been properly cemented.

Article 70

The operator shall, during operations of construction, repair and abandonment of a borehole, ensure that:

- a. a borehole is fitted with safety facilities for sealing purposes;
- b. the reliability of the safety facilities is periodically tested, and
- c. personnel involved in the borehole periodically take part in exercises in the use of safety facilities.

Article 71

A borehole shall not be taken into service for the production of minerals or the storage of substances until it has been properly equipped and completed for this purpose and reliable safety facilities have been installed.

Article 72

A borehole shall not be abandoned until:

- a. sufficient measures have been taken to prevent damage, and**
- b. the mineral-bearing strata and mineral deposits, in so far as they can be damaged by water, have been sealed in a water-tight manner.**

D.1.3 Mining Regulation

General:

Reservoir: a porous and permeable rock, closed off or surrounded by an impermeable rock.

Mechanical plug: i.e. bridge plug, production packer with plug.

Article 8.5.1.2: GENERAL BEFORE SHUTTING OFF A WELL

1. The specific density of the fluid in the wellbore must be high enough to withstand all expected borehole pressures. The fluid must have such a composition that corrosion is prevented and no damage is possible to mineral deposits.
2. Each shut-off used should be such that it is durable and complete.

3. Instead of cement another means may be used provided it results in at least an equal shut off.

Article 8.5.2.1: TESTS

1. Testing of packers, mechanical- or cement-plugs (one is enough)
 - a. weight test of at least 100 kN (10250 kg).
 - b. pressure test of at least 50 bars / 15 min.
 - c. inflow test, whereby no fluid or gas flows into the well from the reservoir.
2. The shut-off method is tested successfully.
3. These tests are not applicable for article 8.5.2.7 section 2 (surface abandonment).

Article 8.5.2.2: PARTLY UNCASSED BOREHOLE

8.5.2.2-1

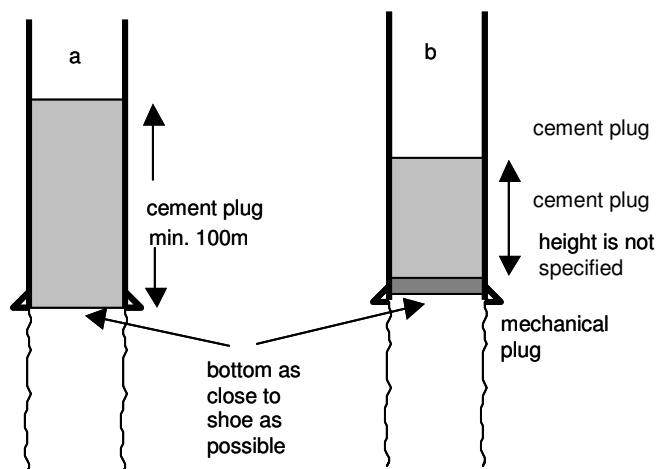

b: height of cement plug has been recently specified to: 50 m length

8.5.2.2-2

8.5.2.2-3

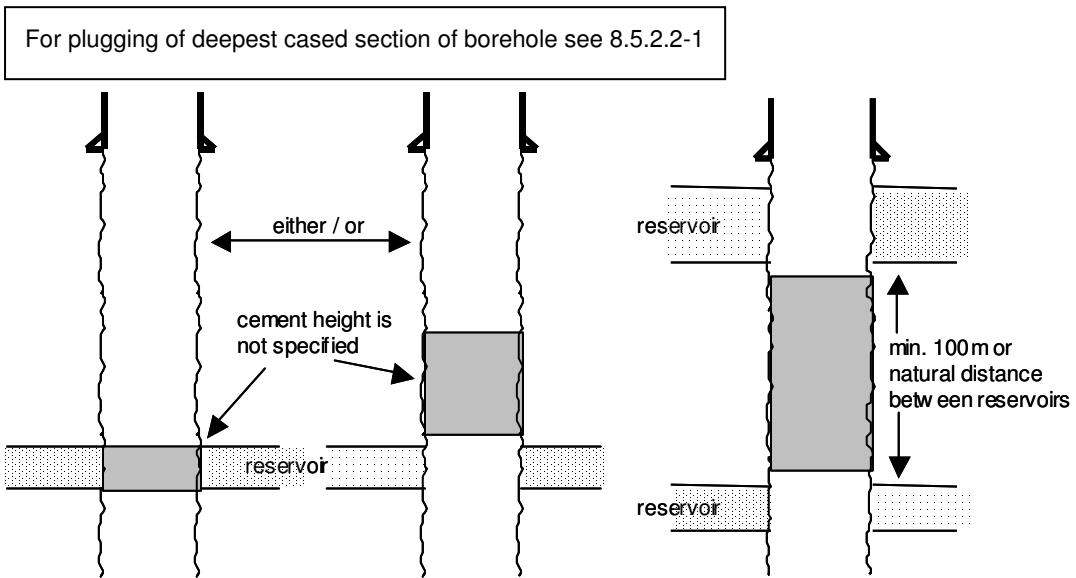

Article 8.5.2.3: PERFORATIONS IN CASED HOLE

8.5.2.3-1

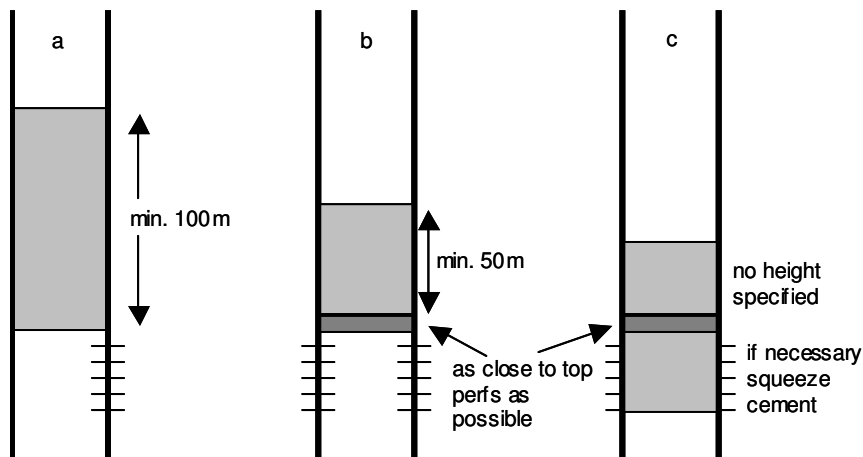

c: height of cement plug has been recently specified to: 50 m length

8.5.2.3-2

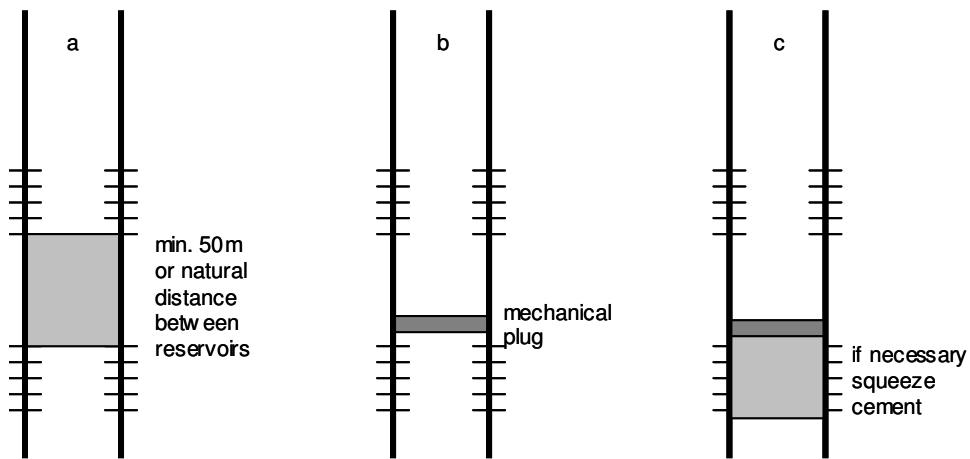

The top perforations have to be shut-off according to article 8.5.2.3-1.

Note: For mechanical shut-offs in articles 8.5.2.2 and 8.5.2.3, **article 8.5.2.8** also applies.

Article 8.5.2.4: CEMENTED LINER

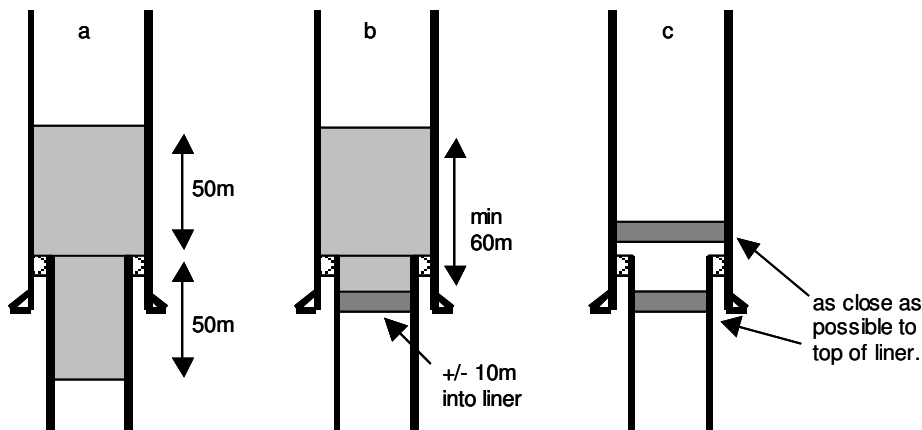

Note: For a mechanical plug **Article 8.5.2.8-1** also applies.

Article 8.5.2.5: ANNULAR SPACES

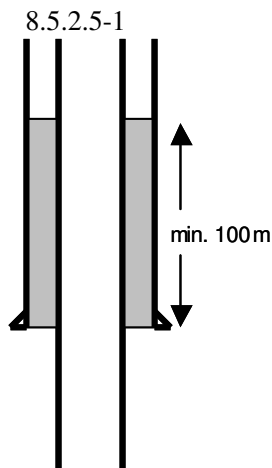

In the article 8.2.4.1 mentioned work program, it must be stated how it is established that the annular seal is present.

If it can not be demonstrated that the annulus between two casings has been sealed off, then:

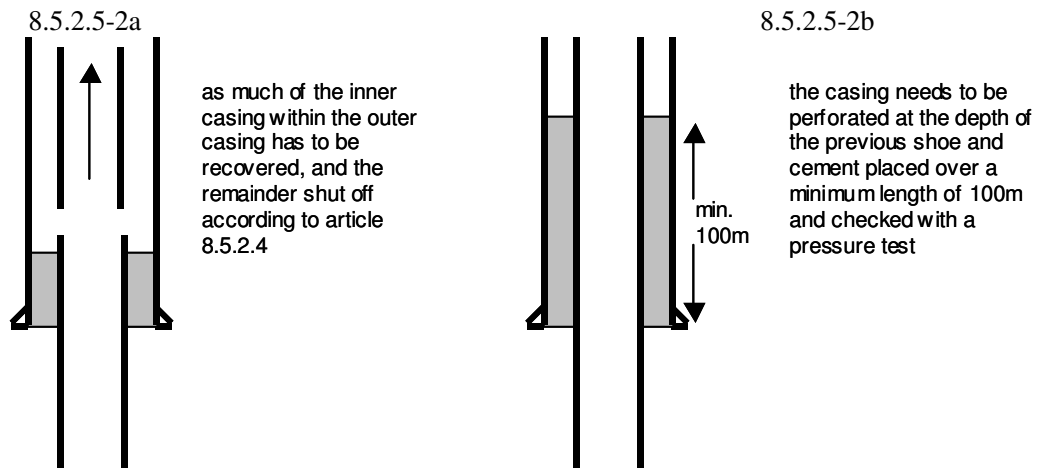

Article 8.5.2.6

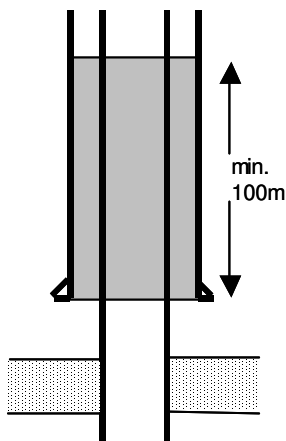

If a formation or a reservoir contains a medium which has the potential to flow to surface, the first annulus closest to the reservoir needs to be abandoned according to article 8.5.2.5.

Article 8.5.2.7: FINISH OF THE TOP OF THE BOREHOLE

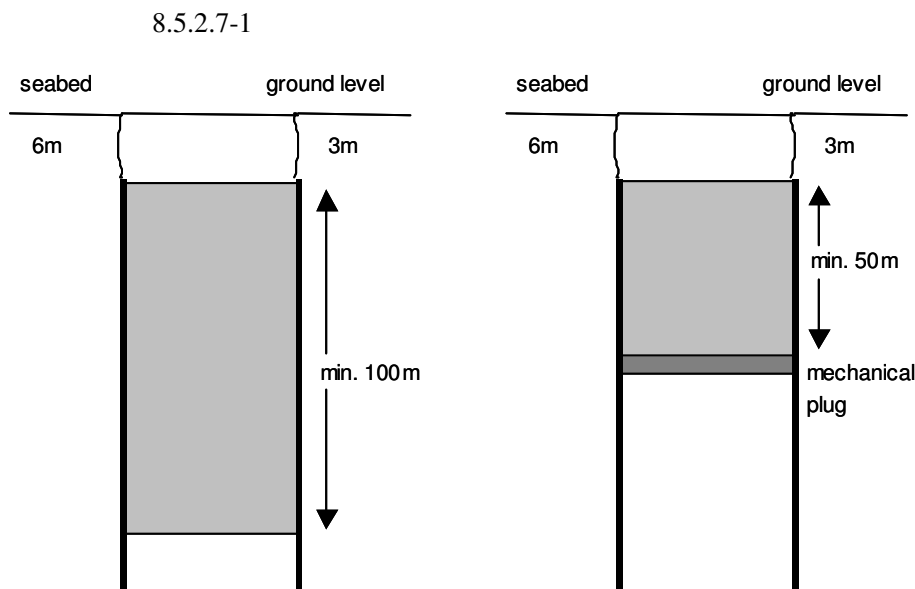

8.5.2.7-3

Exemption to the articles 8.5.2.7-1 and 8.5.2.7-2 can be requested from SodM.

Article 8.5.2.8:

1. If it can be reasonably assumed that a mechanical plug may get into contact with a corrosive medium or if a mechanical plug serves for shutting off a high pressure reservoir, then a cement plug must be placed on top of it of at least 50m in length.
2. A high pressure reservoir is defined as a reservoir with a pressure gradient equal to or higher than 1.4 times the hydrostatic pressure.

D.2 Relevant articles of the Working Conditions Regulation⁴

D.2.1 Working Conditions Act

Article 19

1. If more than one employer has work performed in a business or establishment, they shall cooperate appropriately in order to ensure compliance with the provisions established in or by virtue of this Act.
2. Before work falling under a category specified in an order in council starts, the employers shall ensure that a written description of how they are to cooperate is produced, what action is to be taken in respect of cooperation and how this is to be monitored.

D.2.2 Working Conditions Decree

Article 2.42. Cooperation, health and safety document

1. For the purposes of Article 19, paragraph two, of the Act the activities are designated which are carried out in the opencast industry, the underground mining industry and the mineral-extracting industry by drilling.
2. Before the commencement of the work a health and safety document should be drawn up at least stating:
 - a. the risk assessment and evaluation of the hazards meant in Article 5 of the Act;
 - b. the measures meant in Article 5 of the Act with special attention to the measures taken or to be taken in order to comply with the provisions of this Section and Sections 1, with the exception of division 2a of that Section, 3, 3A, 3B and 3C of Chapter 3 of this Decree;
 - c. the measures taken to prevent a repeat of accidents with serious injuries, fatal accidents or situations as meant in Article 2.41, paragraph four;
 - d. the manner in which Article 19, paragraph two, of the Act has been complied with if, in the workplace in the extracting industry, more than one employer has work carried out;
 - e. the information which shows that the design, use and maintenance of the workplace in the extracting industry and also the work equipment are safe;
 - f. the measures to restrict and fight fires.
3. In addition to the second paragraph under *d* the employer responsible for the workplace in the extracting industry should coordinate the implementation of all health and safety measures and he should indicate in the health and safety document the aims, the measures and the manner in which this implementation is coordinated.

⁴ DISCLAIMER

This is an unofficial translation into English of the official Dutch Legislation. This translation is intended only as informational support. Only the texts published in the Dutch Official 'Staatsblad' are authentic.

4. The health and safety document should be reviewed when there is any relevant change, expansion or conversion of the workplace in the extracting industry.
5. A copy of the health and safety document must be sent to the Works Council or staff representation body, or failing this, to the interested employees.
6. The activities should be carried out in accordance with the health and safety document.

Article 2.42f. Health and safety document

1. Notwithstanding Article 2.42 the health and safety document should demonstrate that all the necessary measures have been taken to protect the health and safety of employees both in their normal situations as well as in emergencies. To this end the document includes the following:
 - a. a specification of the specific risk sources attached to the workplace including any activity at that location which can cause accidents with serious consequences for the health and safety of the employees involved;
 - b. an evaluation of the risks of the specific sources meant under a;
 - c. the evidence that sufficient precautions have been taken to avoid the accidents meant under a, to limit the increase of accidents and to be able to evacuate the workplace in emergencies in an effective and controlled manner;
 - d. the evidence that a health and safety protection system as meant in Article 2.42e is applied that is adequate to comply with the provisions in or pursuant to this Decree with regard to the safety and protection of the health of the employees, both in normal situations as well as in emergencies.
2. With regard to the planning and implementation of all the stages meant in Article 3.2, first paragraph, second sentence, the procedures and implementation provisions stated in the respective health and safety document must be complied with.
3. Should the occasion arise the various employers who are responsible for the various workplaces must cooperate in formulating the health and safety documents meant in Article 2.42 and in preparing the measures necessary to guarantee the health and safety of the employees.
4. With respect to the first, second and third paragraph detailed provisions can be laid down in a Ministerial Order.

D.2.3 Working Conditions Regulation

Section 3.2 Extracting industry through drilling

This section deals with the specifications, definitions, screening and content of the health and safety aspects. The section is organized as follows:

3.2 Definitions

3.2a. Defining risks and limits

3.3, 3.4 & 3.5 Safety and Health care system, definition, screening

3.6, 3.7, 3.8, 3.9 & 3.10 Safety and Health document, for labour and mining installations; definition and content

3.11 & 3.12 Submission of data to the Inspection body; e.g. Safety and Health documents

3.13 Comply with regulations

3.14 Emergency plan

Appendix E United Kingdom

This appendix contains the Guidelines for the Suspension and Abandonment of Wells by UKOOA (UKOOA, 1995).

Required Standards for Abandonment

1. Acceptable Permanent Barriers

Barrier (plugging material) requirements

The main characteristics of abandonment materials should be as follows:

Very low permeability; to prevent flow of Hydrocarbons or overpressured fluids through the barrier;

- Long term integrity; long lasting isolation characteristics of the material, not deteriorating over time;
- Non shrinking; to prevent flow between the barrier-plug / casing annulus;
- Ductile, non-brittle material; to accommodate mechanical loads and changes in the pressure and temperature regime (conversion of producers to water injectors, steam injection, unconsolidated formations, etc.);
- Resistance to downhole fluids and gases (CO₂, H₂S, HCs, etc.);
- Able to bond to the casing or formation in which it is placed.

Note that the downhole placement technique of the plugging material is extremely important, especially in cases of through tubing applications. Allowances will have to be made on the volumes to cater for contamination and shrinkage.

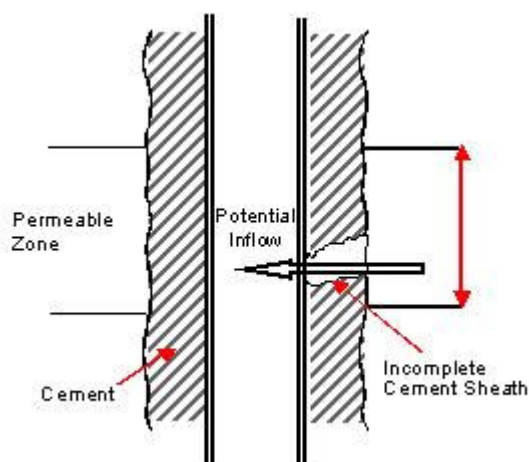

Figure 4 Potential inflow from permeable zone if incomplete localised cement sheath and leak in casing.

The following are accepted as Permanent Barriers:

a. Cement Plugs

A cement column of at least 100 ft measured depth of good cement (see 6.4 Verification) is considered to constitute a Permanent Barrier. Generally, where possible, 500 ftAHD plugs are set. Where Distinct Permeable Zones are less than 100 ft apart, then a 100 ft column of good cement below the base of the upper zone, where practical, should suffice.

Cased hole Plug:

To constitute a Permanent Barrier, the annuli should have good cement positioned opposite the cement plug in order to achieve full lateral coverage of cement in the well.

Open hole Plug:

A cement plug in open hole can constitute a Permanent Barrier to flow between Distinct Permeable zones (i.e. Separation Barrier), and for isolation from surface / seabed if it is adequately verified.

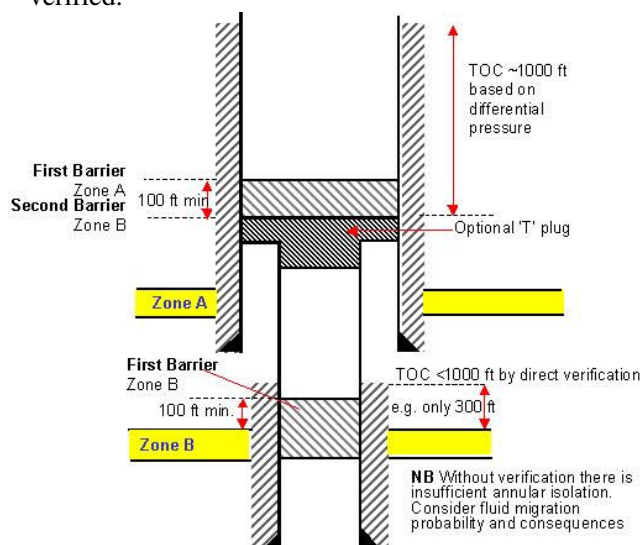

Figure 5 General requirements for abandonment

b. Cemented Casing

Cemented casing is a sufficient barrier to (vertical) flow in the annulus as long as there is sufficient confidence about the quality of the cement in the annulus. Cemented casing is not considered to constitute a Permanent Barrier to flow (laterally) into or out of the wellbore. This is because of the possible migration of fluids as a result of potential casing leak(s) in conjunction with an incomplete localised cement sheath (see Figure 4).

Formations that belong to different Pressure Regimes should be separated by one Permanent Barrier internally, i.e. a cement plug inside the casing, overlapping good annular cement. This should be attempted whether the casing is perforated or not (see Figure 5).

It is acceptable for multiple perforations in separate Distinct Permeable Zones to be separated by a mechanical barrier only (e.g. bridge plug) provided they share the same Pressure Regime, i.e. where segregation has been required for reservoir management reasons only.

In this case, the reason for continued segregation is of finite duration, and hence a Temporary Barrier will suffice.

c. Alternative plugging materials

Cement is currently used in the oil field as the prime material for abandonment purposes. This does not preclude the use of other materials. Alternative materials should generally conform to the requirements above. The long-term integrity of materials should be documented. Once placed, there should be a means by which the barriers can be verified.

2. Permanent Barrier Location for Isolation from Surface.

The following location of Permanent Barriers to achieve isolation from surface/seabed is recommended:

The **First Barrier** should be set across or above the highest point of potential inflow (top Permeable Zone or top perforations, whichever is shallower), or as close as reasonably possible. It should overlap annular cement if set inside a liner or casing. In situations where the base of the plug is significantly above the point of inflow (e.g. set on top of production packer), the Formation Fracture Pressure at the base of the plug should be in excess of the Potential Internal Pressure. Such exposure may arise from a

leak into the casing at the Permeable Zone (see Figure 5). The top of the First Barrier should extend at least 100 ft above the highest point of potential inflow.

The **Second Barrier**, when required should be set with the following considerations:

Relative position of cement in the annulus and shallow Permeable Zones.

Backup to the First Barrier: The same considerations apply with respect to the Second Barrier being positioned such that the Fracture pressure at the base of the plug is in excess of the potential internal pressure. Note that the Second Barrier of one Permeable Zone can be the First Barrier for another, shallower positioned, Permeable Zone.

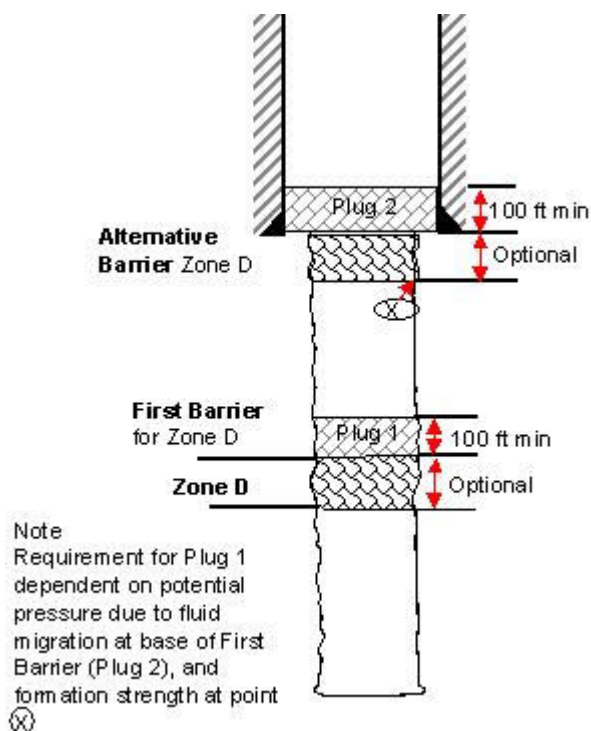

Figure 6 General requirements for abandonment

3. Minimum requirements for Permanent Barriers.

a. Open Hole

In general, an open hole cement plug can be considered a First Permanent Barrier for isolation from surface or seabed provided it has been appropriately verified, usually weight tested.

- Separation Barrier: At least 100ft of good cement should separate Distinct Permeable Zones (see 6.1.a above where zones are less than 100ft apart).
- Plugs on bottom: Are not required.

b. Casing Shoe

If a Distinct Permeable Zone is present in open hole below a Casing shoe, it should be isolated by:

- A First Barrier, an open hole plug, if the distance to the shoe is such that there is potential for pressure at the shoe to exceed the Formation Fracture Pressure, or,
- A First Barrier set across and at least 100 ft into the previous casing shoe (see Figure 6).

c. Perforated Casing

A cement plug is required of at least 100 ft above the top perforations, or the top Permeable Zone, whichever is shallowest. It is not always necessary to remove completion equipment or place cement across any of the perforations. The cement may be placed above the top of the packer, provided that the individual perforations belong to the same Distinct Permeable Zone and all other Permeable Zones behind the casing are in the same Pressure Regime. Another consideration, especially with “high-set” production packers, is the potentially inadequate Formation Fracture Pressure at the packer setting depth when the Potential Internal Pressure is taken into account. A Temporary Barrier may be used to separate Distinct Permeable Zones where they are Distinct for Reservoir Management reasons only.

d. Behind Casing

100 ft of good cement in the annulus is a requirement in order to form a Permanent Barrier behind the casing for vertical flow.

The Top of Cement (TOC) in the annulus can be established from cement bond logs, or similar, by direct measurement.

If the estimate of TOC is based on differential pressure or monitored volumes measured during the original cement job then a TOC 1,000 ft above the zone to be isolated is recommended to ensure annular isolation. This length may be reduced on a per well basis, depending on the confidence level as to the TOC.

Problems during cementation should dictate the course of action to be taken in establishing the adequacy of annular isolation. Secondary squeeze cementation may be considered if the isolation provided by the primary cement is inadequate.

e. Casing Cuts and Liner Laps

Casing Cementations should normally provide a sufficient Permanent Barrier to flow in the annulus (see “d” above). Where this is not achieved, the annulus may be squeezed (bullheaded, perforated and circulated or block-squeezed) to achieve a Permanent Barrier. In place of squeezing the annulus, a cement plug set above a casing cut may also be considered to achieve annulus isolation (See 6.2 above for pressure considerations).

Liner laps which have been cemented may generally be considered as a Permanent Barrier if good cement can be assured in the liner lap, e.g. over-flush volumes, inflow/pressure test, etc. No special requirements are necessary, provided operational difficulties were not experienced during cementation, otherwise they should be considered as casing cuts.

It is common practice to set liner top packers immediately after the cement job. The liner lap and packer are normally tested together; therefore it is not possible to know whether the cement in the liner lap, or the packer is holding the pressure. Though this is sufficient for the producing life of a well, a liner packer is not a Permanent Barrier. An additional Permanent Barrier should be placed above the liner lap unless the liner lap can be demonstrated to be fully cemented (see Figure 7).

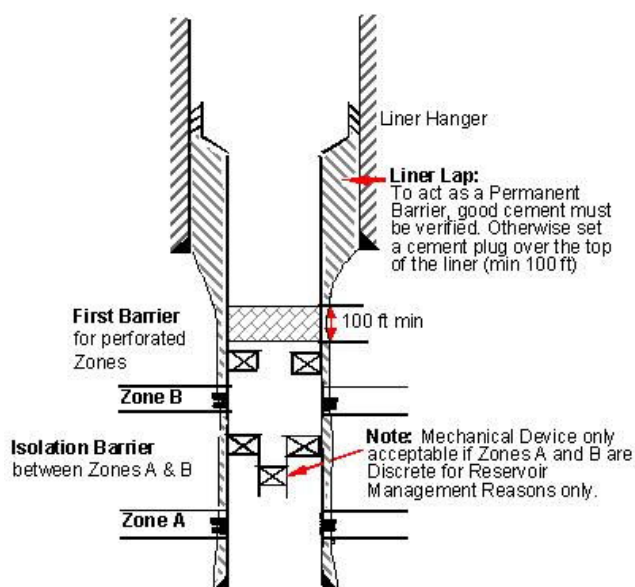

Figure 7 General requirements for abandonment

4. Verification

It is important that the position and effectiveness of Barriers can be confirmed. Any barrier designed to be a Permanent Barrier must be verified.

Verification requirements are highly dependent upon individual well design (e.g. inclination), placement method (e.g. on top of a mechanical device), plug requirements, volumes pumped / loss monitoring and hole section, size and type (e.g. open or cased hole). Placement technique may in itself ensure the required plug quality e.g. large cement column on top of a mechanical / physical device. The criticality of the plug with respect to its exact location and function should also be considered.

The usual methods of verification are weight testing and pressure testing.

The choice of material for the Permanent Barrier may influence the means of verification; some materials may not tolerate weight testing.

Where pressure or inflow testing is deemed necessary, the potential consequences of fracturing a formation or inducing hydrocarbon movement in a failed test should be considered. Fracturing may result in connecting different Pressure Regimes whilst inflow testing may bring hydrocarbons from deeper horizons.

These guidelines do not outline specific requirements for verification. They do, however, recommend minimum requirements. In order to establish the adequacy of a barrier to conform to these guidelines, the following verification is recommended:

a. Open Hole

Any barrier in open hole that is designed to be a Permanent Barrier must incorporate a high degree of redundancy and must be verified.

Barriers in open hole cannot be, generally, satisfactorily pressure tested but can normally be weight tested. A barrier, set on bottom, could be treated as being set on a tested barrier, provided strength development is verified (see below)

There is no requirement to tag cement plugs that isolate Distinct Permeable Zones within the same Pressure Regime, unless operational problems dictate, e.g. excessive hole washout, losses or high deviation. In different Pressure Regimes, particularly zones containing gas, special attention should be taken to eliminate the possibility of crossflow between zones. This may require setting and tagging separate plugs across or between each zone.

b. Cased Hole

The First Barrier, i.e. the first plug above the highest point of potential influx, must be verified. Typically it would be tagged and pressure tested.

It is normally recommended to pressure test to 0.1 psi / ft (500 psi minimum) above the leak-off or estimated formation fracture gradient at the base of the barrier. However the required test pressure is highly dependent on the specific well conditions, casing condition (burst and wear), formation fracture gradient, density of wellbore fluids etc.

The pressure test may be substituted by an inflow test to at least the maximum pressure differential to be experienced by the plug after abandonment.

If the Barrier is set on a previously tested mechanical device inside casing, there is no requirement to verify the plug position or pressure integrity. A cement plug installed using a tested mechanical device as a foundation should be verified by documenting the strength development using a sample slurry subjected to an ultrasonic compressive strength analysis or one that have been tested under representative temperature and / or pressure.

The Second Barrier, i.e. the second plug, should be tagged but there is no requirement to pressure test this barrier, unless it is the First Barrier of a shallower Permeable Zone.

c. Annulus, Casing Cuts and Liner Laps

Where it can be demonstrated that sufficient good cement exists across and above a permeable zone in an annulus, by means of log (e.g. CBL), differential pressure or monitoring volumes, there is no need to pressure or inflow test the annulus.

If there is any doubt as to the top of cement in the casing annulus and whether it complies with the requirements for a Permanent Barrier (ref. 6.3 d, viz. 100 ft or 1,000 ft, dependent on means of verification) then the annulus should be perforated and sufficient good cement circulated or squeezed into the annulus to achieve a Permanent Barrier. An alternative is to cut casing and place cement on top of the cut (See 6.3.e).

All such remedial annular cementations should be verified, usually by pressure testing. Similarly, a plug set across a casing cut or a liner lap should be verified, either by tagging and / or pressure testing.

Where a casing / casing annulus is required to be cemented to form an annular barrier, this should be pressure tested prior to installation of a mechanical device e.g. liner top packer, on a liner lap. Where this test cannot be performed and doubt exists as to the integrity of the cement within the lap, then a Permanent Barrier should be placed over the top of the annulus / liner lap, and should be verified, either by tagging and / or pressure testing.

Appendix F Australia

F.1 Western Australia

Schedule of Onshore Petroleum Exploration and Production Requirements (1991)

This section presents relevant texts concerning well abandonment operations, running well evaluation logs, the application for approval to abandon or suspend a well, reporting on abandonment of a well and the well completion report⁵.

529 Abandonment of a Well

1. In the uncased portions of a well, cement plugs shall be placed such as to provide a minimum of 30m of cement above and a minimum of 30m of cement below any significant oil, gas or fresh water zones.
2. Where there is open hole immediately below the casing string, there shall be placed in that casing string
 - a. a cement plug placed by displacement method so as to extend at least 30m above and at least 30m below the casing shoe; or
 - b. a cement retainer with effective back pressure control set at least 10m, but not more than 30m, above the casing shoe with a cement plug calculated to extend at least 30m below the casing shoe and at least 15m above the retainer; or
 - c. Where lost circulation conditions exist or are anticipated, a permanent type bridge plug set within 45m above the casing shoe with at least 15m of cement on top of the bridge plug.
3. If the casing string is cut and recovered, a cement plug shall be placed to extend at least 30m above and at least 30m below the cut end of the casing string, and a retainer may be used in setting the required plug.
4. Where the casing string has been perforated
 - a. a cement plug shall be placed opposite the perforations and shall extend from at least 30m below to 30m above the perforated interval; or
 - b. the perforated interval may be plugged by means of a cement retainer set in the casing string no more than 45m above the top of the perforated interval with a cement plug extending at least 15m above the retainer, provided the perforated interval is isolated from open hole below; or
 - c. subject to sub-clause (b) where a succession of retainers is used to isolate a series of perforated test intervals, only the topmost retainer need have a minimum of 15m of cement plug placed above it;
5. In a cased hole containing a liner string or strings, a cement plug shall be placed immediately above each liner hanger to extend at least 30m above the liner hanger.
6. A surface cement plug extending at least 15m below the surface shall be placed in the innermost string of casing that extends to the surface.
7. Any annular space that extends to the surface, and which is open to drilled hole, shall be plugged with sufficient cement to fill at least 30m of the annular space;
8. The location and integrity of cement plugs shall be tested in a manner acceptable to the Director;
9. Any intervals of cased hole between cement plugs shall be filled with fluid that is of an appropriate density and suitably inhibited to prevent any corrosion of the casing;
10. Blow-out preventers shall not be removed until all plugs that are required to isolate the open hole have been set and their location and integrity satisfactorily determined;
11. No casing may be recovered if its recovery would expose any abnormal pressure, lost circulation or petroleum or water zone; and

⁵ The complete text is available at [http://www.dmp.wa.gov.au/documents/schedule_onshore_PGERA67\(1\).pdf](http://www.dmp.wa.gov.au/documents/schedule_onshore_PGERA67(1).pdf).

12. A steel well marker plate shall be installed at least two metres above ground level, and that plate shall
 - a. be welded to a suitable steel post that is in turn welded to the casing head or outermost casing stub; and
 - b. have the well name and number bead-welded to it.

636 Plugging of Wells

1. Upon completion of production activities and within 2 years after the surrender of a production licence, all wells will be plugged and abandoned in accordance with Clauses 528 and 529.
2. Wells may remain without being plugged and abandoned in a licence area following 2 years after the surrender of a production licence only with approval.
3. The Director may direct that a well or wells be plugged and abandoned within a reasonable time-frame determined by the Director –
 - a. in the interest of safety;
 - b. for the protection of the environment; or
 - c. for the purpose of the elimination of waste or contamination.

F.2 Queensland

Petroleum and Gas (Production and Safety) Regulations 2004

Only the relevant texts of the Petroleum and Gas (Production and Safety) Act 2004 are presented here⁶. In the Petroleum and Gas (Production and Safety) Regulations 2004 the following is stated on the decommissioning of petroleum wells.

60 Plugging and abandoning a petroleum well or bore

1. For section 292(4)(a)(i) of the Act, a petroleum well or bore must be plugged and abandoned in the way stated in schedule 3.
2. Also, the safety requirements stated in sections 69 and 70 apply for plugging and abandoning a well.

70 Requirement to cement particular voids in a prescribed well

1. This section prescribes safety requirements for plugging and abandoning a prescribed well at an operating plant if—
 - a. a void is created by stimulation of a coal seam in the well; and
 - b. the void is sufficiently large that it may adversely affect—
 - i. the safe and efficient future mining of coal from the seam; or
 - ii. the integrity of the natural underground reservoir in which the void is created.
2. The operator must ensure that, as part of the plugging and abandoning of the well, the void is filled with as much cement as is reasonably practicable.
3. Subject to schedule 3, the cement used to fill the void must not be so strong that it unduly prevents the future efficient mining of coal from the seam.
4. This section applies in addition to the standard abandonment requirements for the well.

For requirements about removing casing from a petroleum well, see schedule 3.

Schedule 3 Requirements for plugging and abandoning petroleum wells and bores section 60(1)

⁶ The complete text is available at:

<http://www.legislation.qld.gov.au/LEGISLTN/CURRENT/P/PetrolmGasR04.pdf>, website visited March 2009

Part 1 Preliminary

1 Definitions for schedule 3

In this schedule —

prescribed well or bore means a well or bore, other than a horizontal well.

well or bore means a petroleum well or bore drilled under a petroleum authority.

Part 2 Requirements for all wells and bores

2 Abandonment to be consistent with good industry practice

A well or bore must be abandoned in accordance with good industry practice, to the extent that practice is consistent with this regulation.

3 Capping of well or bore

The well or bore must be capped with a metal plate inscribed with the following information—

- a. the identifying name of the well or bore;
- b. the total depth in metres of the well or bore;
- c. the date the well or bore was abandoned.

4 Casing to be sealed

1. The casing of the well or bore must be sealed below ground level.
2. The stub of the casing must be buried below the surface at a depth that—
 - a. allows for the efficient later re-entry to the well or bore; and
 - b. will not adversely interfere with the normal activities of the owner of the land on which the well or bore is located.

Part 3 Additional requirements for wells and bores, other than horizontal wells

5 Isolation of aquifers and porous formations

An aquifer or porous formation, including, for example, a coal seam, that is intersected by a prescribed well or bore must be isolated so there is no interconnection of gas or water between the aquifers or porous formations.

6 Casing of prescribed well or bore

1. Steel casing must be removed from any section of a prescribed well or bore that is within or immediately adjacent to a coal seam.
2. However, subsection (1) need not be complied with if it is not technically or commercially feasible to remove the casing.

Example—

production casing that has been cemented in place and can not feasibly be removed

7 Cement to be used for plugs etc.

1. A prescribed well or bore must have a surface plug of cement in the casing.
2. Also, if a prescribed well or bore has more than 1 casing string and any inner casing string does not reach the surface, the inner casing string must, if required to comply with section 5, be plugged with cement at the top of the string.
3. Cement used as a plug in a prescribed well or bore must be of an industry accepted grade, having regard to the salinity of the fluids in the surrounding strata.
4. A plug in, or adjacent to, a coal seam in a prescribed well or bore must, if reasonably practicable, be adequately secured.
5. The operator of the well or bore must test any cement that is used as a plug in the well or bore and ensure that it complies with the requirements under this regulation.

8 Requirement for packer left in prescribed well or bore

A packer in, or adjacent to, a coal seam in a prescribed well or bore that is not to be removed from the well or bore must, if reasonably practicable—

- a. be made of a material that is intrinsically safe; and
- b. be adequately secured.

9 Fluid to be left in prescribed well or bore

A prescribed well or bore must be left full of fluid that is of sufficient density to—

- a. help maintain the structural integrity of the well or bore; and
- b. prevent gas influx.

10 Requirements if steel casing or drill string is left in coal seam

1. This section applies if steel casing or drill string is left within a coal seam in a prescribed well or bore.
2. The well or bore must be abandoned in a way that assists future entry of the well or bore for the purpose of milling or removing steel from the coal seam.
3. In complying with subsection (2), the operator must ensure that each of the following is carried out before the well or bore is plugged and abandoned—
 - a. sucker rods, pump and tubing and any other debris in the well or bore that can practicably be removed are removed;
 - b. perforated casing is cemented to ensure all aquifers and porous formations, including for example, coal seams, are isolated as required under section 5;
 - c. if casing remains in the well or bore, the fluid left in the well or bore as required under section 9—
 - i. is anti corrosive; and
 - ii. has corrosion inhibitor added to it if the fluid is or may become corrosive;
 - d. casing strings are cut off at approximately 1.5m below ground level and all wellhead equipment is removed;
 - e. before backfilling, a metal plate is welded fully across the top of the innermost casing string and marker tape is laid approximately 20cm above the top of the casing;
 - f. a plaque, stating the following information, is placed on the nearest fence, building or other permanent structure—
 - i. the identifying name of the well or bore;
 - ii. the total depth in metres of the well or bore;
 - iii. the date on which the well or bore was abandoned;
 - iv. the distance and direction to the well or bore from the plaque.

Part 4 Additional requirement for horizontal wells

11 Requirement for liner

1. A horizontal well must be abandoned containing a slotted liner that is not made of steel, including for example, a slotted PVC liner.
2. However, if the horizontal well has the potential to be a high risk area for future coal mining because of high levels of methane, the operator must conduct a risk assessment that
3. includes an assessment of whether a Fire Resistant Anti Static (or FRAS) liner should be used in the well.

Appendix G Alberta, Canada

The information in this appendix has been summarized from ERCB (2007). The ERCB has approved the text in this appendix.

G.1 Open-hole abandonment requirements

The information in this appendix has been summarized from ERCB (2007).

This appendix provides an overview of both the general as well as the specific well abandonment requirements for the different Program Areas.

General requirements

1. All plugs run at a depth less than 1500 m must be a minimum length of 30 m, and they must extend a minimum of 15 m below and a minimum of 15 m above the porous zone being covered.
2. All plugs run at a depth greater than 1500 m must be a minimum length of 60 m, and they must extend a minimum of 15 m below and a minimum of 15 m above the porous zone being covered.
3. A plug may extend over more than one porous zone.
4. There is no minimum distance between plugs as long as the pressure from the zone being isolated does not exceed the fracture pressure of the interval left open above it.
5. Any plug may be staged; however, the break between stages in a multistage plug must occur within a zone and may not occur at a zone top.
6. The location of each plug must be confirmed by one of the approved methods described in ERCB (2007).

Specific requirements per Program Area

Program Area 1

1. Thermal cement blends must be used when abandoning wellbores that access or pass through oil sands.
2. The requirements for protecting nonsaline groundwater are as follows:
 - In a well where the surface casing is set above the base of groundwater protection, a plug must be run from 15 m below the base of the nonsaline groundwater to 15 m above the surface casing shoe.
 - In a well in which intermediate casing has been run but has not been cemented full length and the surface casing is set above the base of groundwater protection, the ERCB requires remedial cementing to cover groundwater.
 - In a well where surface casing is set below the base of groundwater protection, a plug must extend from a minimum of 15 m below the surface casing shoe to 15 m above it.

Program Area 2

Prescribed Plugging Program for Non-Oil Sands Wells

Wells in Program Area 2 (but not within the Cold Lake or Athabasca oil sands areas) must follow the following program:

1. Bottom Plug
A bottom plug must be set from the well's total depth to a minimum of 15 m above the top of the Grand Rapids Formation (Mannville Group).
2. Top Plug
A top plug must be set from a minimum of 15 m below the top of the Viking Formation to a minimum of 15 m above the surface casing shoe.

Prescribed Plugging Program for Oil Sands Wells

Wells within the Cold Lake or Athabasca oil sands areas must follow the following program:

1. Bottom Plug

A bottom plug must be set from the well's total depth to a minimum of 15 m above the top of the Grand Rapids Formation (Mannville group) using thermal cement. Excess cement above the top of the plug must be reverse circulated to surface.

2. Top Plug

A top plug must be set from a minimum of 15 m above the top of the Grand Rapids Formation (Mannville group) to a minimum of 15 m above the surface casing shoe.

Program Area 3

Wells in Program Area 3 must follow the following program:

1. Bottom and Intermediate Plugs

If the well's total depth is shallower than the Wabamun Formation, a bottom plug must be set from the well's total depth to a minimum of 15 m above the top of the Viking Formation. An intermediate plug is not needed. If the well's total depth is deeper than the Wabamun Formation, a bottom plug must be set from the well's total depth to a minimum of 15 m above the top of the Nisku Formation. An intermediate plug must be set a minimum of 15 m below the base of the Wabamun to a minimum of 15 m above the top of the Viking Formation.

2. Top Plug

A top plug must be set from a minimum of 15 m below the top of the Lea Park Formation to a minimum of 15 m above the surface casing shoe.

Program Area 4

The prescribed plugging program for wells in Program Area 4 depends on whether the Medicine Hat Formation has more than 3 per cent porosity.

Wells with Less Than 3 per cent Porosity in the Medicine Hat Formation

Wells with less than 3 per cent porosity in the Medicine Hat Formation are not required to isolate the Second White Specs Formation.

1. Bottom Plug

A bottom plug must be set from the well's total depth to a minimum of 15 m above the base of the Mannville Formation.

2. Intermediate Plug

An intermediate plug must be set from a minimum of 15 m below the base of the Viking/Bow Island Formation to a minimum of 15 m above the top of the Viking/Bow Island Formation.

3. Top Plug

A top plug must be set from 15 m below the base of the Milk River Formation to 15 m above the surface casing shoe.

Wells with More Than 3 per cent Porosity in the Medicine Hat Formation

Wells with more than 3 per cent porosity in the Medicine Hat Formation are required to isolate the Second White Specs Formation. There are two options for isolating the White Specs Formation:

Option 1

1. Bottom Plug

A bottom plug must be set from the well's total depth to a minimum of 15 m above the base of the Mannville Formation.

2. Intermediate Plug

An intermediate plug must be set from a minimum of 15 m below the base of the Viking/Bow Island Formation to a minimum of 15 m above the top of the Viking/Bow Island Formation.

3. Top Plug

A top plug must be set a minimum of 15 m below the base of the Medicine Hat Formation to a minimum of 15 m above the surface casing shoe.

Option 2

1. Bottom Plug

A bottom plug must be set from the well's total depth to a minimum of 15 m above the base of the Mannville Formation.

2. Intermediate Plug
An intermediate plug must be set from a minimum of 15 m below the base of the Viking/Bow Island Formation to a minimum of 15 m above the top of the Second White Specs Formation.
3. Top Plug
A top plug must be set from a minimum of 15 m below the base of the Milk River formation to a minimum of 15 m above the surface casing shoe.

Oil Sands Evaluation and Test Hole wells

The general requirements for abandonment do not hold for Oil Sands Evaluation (OV) and Test Hole (TH) wells. The OV wells must be filled with thermal cement from final total depth to surface. The TH wells, drilled outside a designated oil sands area must be filled with class G cement from final total depth to surface. In addition, fluid level tests and gas migration tests are not required.

G.2 Cased-hole abandonment requirements

Zonal abandonment within a completed well (not penetrating oil sands zones)

After each completed interval is abandoned, the wellbore must have an inhibitor added to prevent corrosion.

Non-completed Wells

Non-completed wells (that is, wells that do not have any perforations) do not require additional cement plugs to be run if the existing casing string is pressure tested at a stabilized pressure of 7000 kPa for 10 minutes.

Wells with a Cemented Liner

To abandon a well with a cemented liner, a minimum 30 m cement plug is required to be run across the liner top (i.e., the hanger). For deviated wells, the cement plug length must equate to 30 vertical metres of cement. The plug must extend from a minimum of 15 m below the liner top to a minimum of 15 m above the liner top. The plug must be pressure tested at a stabilized pressure of 7000 kPa for 10 minutes.

Wells with an Uncemented Liner

To abandon a well with an uncemented liner across more than one formation, the well must be abandoned according to the open-hole abandonment requirements. The zones behind the liner must be evaluated for porosity, and the porous zones must be covered by cement or isolated between cement plugs. Once the liner has been cemented, a minimum 30 m cement plug is required to be run across the liner top (i.e., the hanger). For deviated wells, the cement plug length must equate to 30 vertical meters of cement. The plug must extend from a minimum of 15 m below the liner top to a minimum of 15 m above the liner top. The plug must be pressure tested at a stabilized pressure of 7000 kPa for 10 minutes.

Completed Horizontal Wells in a Single Formation

In a horizontal open-hole interval that penetrates one formation, a bridge plug must be set within 15 m TVD (total vertical depth) of the top of the formation in which the horizontal zone is completed. Once the bridge plug has been set, it must be pressure tested at a stabilized pressure of 7000 kPa for 10 minutes. The plug must be capped with either a minimum of 8 vertical meters of class G cement or a minimum of 3 vertical meters of hydromite.

Completed Horizontal Wells across Multiple Formations

In a horizontal open-hole interval that penetrates multiple formations, each formation must have a cement plug set in the open-hole section to either cover or isolate the porous zones within the different formations. A minimum 30 vertical meter cement plug is required, extending either a minimum of 15 m below the formation or the plug-back total depth, whichever is shallower, to a minimum of 15 m above the porous zone. The location of each plug must be confirmed by one of the approved methods described in ERCB (2007).

Zonal Abandonment within a Completed Well

The licensee must use one of the following methods for abandoning zones within a completed well:

1. **Setting a Bridge Plug**
A bridge plug must be set within 15 m above the perforation or the single-zone open-hole section. Once the bridge plug has been set, it must be pressure tested at a stabilized pressure of 7000 kPa for 10 minutes. The plug must be capped with either a minimum of 8 linear meters of class G cement or with a minimum of 3 m of hydromite.
2. **Setting a Cement Retainer**
A cement retainer must be set within 15 m above the perforations or the single-zone open-hole section. The retainer must be pressure tested at a stabilized pressure of 7000 kPa for 10 minutes. A cement squeeze must be conducted into the perforations or the single-zone open-hole section. The retainer must be capped with a minimum of 8 linear meters of class G cement. If this plug is to be drilled out, the squeezed interval must be pressure tested at a stabilized pressure of 7000 kPa for 10 minutes.
3. **Setting a Plug in a Permanent Packer**
A plug must be set in a permanent packer within 15 m above the perforation or the single-zone open-hole section. The plug and packer must be pressure tested at a stabilized pressure of 7000 kPa for 10 minutes. Then the plug and packer must be capped with either a minimum of 8 linear metres of class G cement or with a minimum of 3 m of hydromite.
4. **Squeezing Cement**
A cement squeeze must be conducted into the perforations or the single-zone open-hole section. After the cement has set, the top of the cement must be confirmed by one of the approved methods described in ERCB (2007). The plug must be pressure tested at a stabilized pressure of 7000 kPa for 10 minutes. The plug must extend from a minimum of 15 m below the completion or total depth, whichever is shallower, to a minimum of 15 m above the completion. If this plug is to be drilled out, the squeezed interval must be pressure tested at a stabilized pressure of 7000 kPa for 10 minutes.
5. **Setting a Cement Plug**
A cement plug must be set across the perforations or the single-zone open-hole section. The plug must extend a minimum of 15 m above the top of the completed interval and a minimum of 15 m below either the completed interval or the plug-back total depth, whichever is shallower. The location of each plug must be confirmed by one of the approved methods described in ERCB (2007). The plug must be pressure tested at a stabilized pressure of 7000 kPa for 10 minutes.

Zonal abandonment within a completed well (penetrating oil sands zones)

The following are the requirements for abandonment operations on cased-hole wells that penetrate oil sands zones.

Non-completed Wells

All non-completed oil sands zones must have a thermal cement plug run across the oil sands formation with a minimum of 15 m of thermal cement above the top of the formation and a minimum of 15 m below the formation or the plug-back total depth, whichever is shallower. This plug may be combined into a longer plug to cover two or more uncompleted oil sands zones. The location of each plug must be confirmed by one of the approved methods described in ERCB (2007). Then, the plug must be pressure tested at a stabilized pressure of 7000 kPa for 10 minutes.

Completed Wells

If the well being abandoned penetrates an oil sands zone, each oil sands zone that is penetrated must be abandoned using one of the following methods:

For abandoning zones within a completed well, one of the following methods must be applied:

1. **Setting a Bridge Plug**
A bridge plug must be set within 15 m above the perforations or the single-zone open-hole section. Once the bridge plug has been set, it must be pressure tested at a stabilized pressure of 7000 kPa for 10 minutes. Then the plug must be capped with a minimum of 8 linear meters of thermal cement. The cement top must extend to a minimum of 15 m above the formation top.
2. **Setting a Cement Retainer**
A cement retainer must be set within 15 m above the perforations or the single-zone open-hole section. The retainer must be pressure tested at a stabilized pressure of 7000 kPa for 10 minutes. A thermal cement squeeze must be conducted into the perforations or the single-zone open-hole section. The retainer must be capped with a minimum of 8 linear meters of thermal cement. The cement top must extend to a minimum of 15 m above the formation top. If this plug is to be drilled out, the squeezed interval must be pressure tested at a stabilized pressure of 7000 kPa for 10 minutes.
3. **Setting a Plug in a Permanent Packer**
A plug must be set in a permanent packer within 15 m above the perforation or the single-zone open-hole section. The plug and packer must be pressure tested at a stabilized pressure of 7000 kPa for 10 minutes. Then, the plug and packer must be capped with a minimum of 8 linear meters of thermal cement. The cement top must extend to a minimum of 15 m above the formation top.
4. **Squeezing Cement**
A thermal cement squeeze must be conducted into the perforations or the single-zone open-hole section. After the cement has set, the top of the cement must be confirmed by one of the approved methods described in ERCB (2007). The plug must be pressure tested at a stabilized pressure of 7000 kPa for 10 minutes. The plug must extend from a minimum of 15 m below the completion or total depth, whichever is shallower, to a minimum of 15 m above the completion. If this plug is to be drilled out, the squeezed interval must be pressure tested at a stabilized pressure of 7000 kPa for 10 minutes.
5. **Setting a Cement Plug**
A thermal cement plug must be set across the perforations or the single-zone open-hole section. The plug must extend a minimum of 15 m above the top of the formation and a minimum of 15 m below either the completed interval or the plug-back total depth, whichever is shallower. The location of each plug must be confirmed by one of the approved methods described in ERCB (2007). The plug must be pressure tested at a stabilized pressure of 7000 kPa for 10 minutes.

The licensee must review the well logs to determine which oil sands zones have been penetrated by the well. After each completed interval is abandoned, the wellbore must have an inhibitor added to prevent corrosion. Thermal cement must be used when abandoning wellbores that penetrate oil sands.

G.3 Removing Casing and Setting a Cement Plug

If the casing is free at or below the base of all nonsaline groundwater, the licensee may cut and pull the casing. Casing removal schemes that meet the following requirements are routine. Any casing string other than the surface casing may be removed. The intended cut point must be identified at or below the base of all nonsaline groundwater. A bridge plug must be set a minimum of 15 m below the intended cut point. Next, the plug must be pressure tested at a stabilized pressure of 7000 kPa for 10 minutes. The casing may then be cut and pulled. A cement plug must be set from the bridge plug to a minimum of 15 m above the surface casing shoe. If the casing is unsuccessfully severed, a cement plug of a minimum of 30 m must be placed across the intended cut point. The cement plug must be located and pressure tested at a stabilized pressure of 7000 kPa for 10 minutes.

Appendix H China

The Control Rules on offshore Oil Well Abandonment Operations

In this appendix, the relevant articles from the original text⁷ of the Control Rules on offshore Oil Well Abandonment Operations of the People's Republic of China is presented⁸.

Article 1

These Rules are formulated in accordance with "The Safety Control Provisions on Offshore Petroleum Operations of the Ministry of Petroleum Industry of the People's Republic of China" and the relevant control provisions for the purpose of ensuring the safety of oil and gas well abandoned permanently or temporarily, the protecting of petroleum and mineral resources under the sea bed and offshore environment, ensuring the safety of navigation.

Article 2

These Rules are applicable to the operators and contractors conducting the exploration, development and production and other offshore petroleum operations in the internal waters, territorial sea and continental shelf of the People's Republic of China and in all areas within the limits of national jurisdiction over the maritime resources of the People's Republic of China.

Article 4 The Technical Requirements for Well Abandonment Operations

1. The well abandonment operations shall meet the following conditions: the formations of different pressure system have been plugged completely and the formation fluid can be avoided flowing beyond the surface of sea bed.
2. Permanent Well Abandonment
 - a. In order to plug the permeable stratum of oil, gas, water and other fluid and to avoid the inter-penetration or the same flowing to the sea bed in the borehole, the cement plug shall at least be thirty-meters higher than any of such permeable stratum of oil, gas, water and other fluid, and the length of the cement plug shall not be less than fifty-meters, and when the borehole has no oil, gas and water strata, the thirty-meter cement plug above and below the last casing shoe shall be plugged respectively.
 - b. If there is a liner, the thirty-meter interval above and below the top of the liner shall be plugged with thirty-meter cement plug respectively.
 - c. If the perforated testing operations have been conducted in the casing or liner, a bridge plug shall be placed fifteen-meters above the top of the tested oil bearing zone, and the cement plug of fifty-meters above the bridge plug shall be plugged after the pressure testing has been conducted and met the requirement.
 - d. When the casing has been cut, a thirty-meter length of cement plug shall be plugged above and below the casing cutting point respectively.
 - e. The length of the last cement plug shall in the surface casing be at least forty five-meters, and the location of the top of the cement plug shall be between four to thirty-meters below the mudline of sea bed.
3. Temporary Well Abandonment
 - a. At the bottom of the deepest casing shall be plugged with at least fifty-meter cement plug.
 - b. The cement plug of at least thirty-meter length shall be plugged within the casing four meters below the mudline of sea bed.

Article 5 Wellhead Residuum

⁷ The text is available at <http://winwin.redcome.com/servlet/Report?Node=17306>

⁸ DISCLAIMER: The English version of this document is an unofficial translation. In case of discrepancy, the original Chinese text shall prevail.

1. In case of permanent well abandonment, all casings, well head assembly or pile shall be removed up to four meters below the mudline of sea bed in accordance with the relevant provisions.
2. The subsea well head assembly or well head cap remained on the sea bed shall be reported in accordance with the relevant provisions.

Article 9 Definition

"Well Abandonment Operations" means the permanent or temporary well abandonment operations.
"Permanent Well Abandonment" means the operations to plug the well bore and to recover the well head assembly of the abandoned wells which cannot be re-utilized .

"Temporary Well Abandonment" means the operations to plug well bore, installing well head cap and placing well head signal of the well in which drilling is ongoing and the operation is suspended due to some reasons or in which operations have been completed and to remain the well head is necessary.

"Wellhead Residuuum" means the substances remained at the well head above the mudline of sea bed after the completion of well abandonment operations.

Appendix I Japan

Well abandonment regulations by METI

This appendix contains a translation⁹ of the well abandonment regulations in Japan¹⁰. Two different cases for abandonment are distinguished. First of all, regulations are defined for abandonment of wells for oil or natural gas production from structural reservoirs. Secondly, regulations are defined for wells producing natural gas that is dissolved in water.

Abandonment of wells producing oil and natural gas from structural reservoirs

In general, cement plugs shall be made through the displacement of mud by cement, unless a cement retainer is present. The cement shall be oil-well cement conform the API standards.

The abandonment regulations are as follows:

- A. If completion or testing layers are present in the open hole of a well two plugs are required:
 1. A cement plug of at least 30 m shall be placed, extending above the top edge of the considered layer, and,
 2. A cement plug of 30 m shall be placed, extending at least 30 m below the base of the considered layer.These plugs are not required if it is verified that the formation fluid does not rise above the surface under its own pressure.
- B. If an open hole exists below the last casing, the well shall be sealed in one of the following ways:
 1. Cement plugs of at least 30 m shall be inserted both above and below the deepest casing shoe. If completion or testing layers exist within 30 m from the top of the casing shoe, cement plugging can be conducted at a level where these layers are not being damaged, or,
 2. A bridge plug shall be placed immediately above the casing shoe.
- C. Wells shall be sealed immediately above perforated sections in one of the following ways:
 1. A cement plug of at least 30 m shall be placed above the top of the perforated section. In case completion or testing layers are present within 30 m of the top of the perforated section, plugging shall be conducted at a level these layers are not being damaged, or,
 2. A bridge plug shall be placed immediately above the top of the perforated section. If multiple perforated sections are sealed by bridge plugs only, it is required to place a cement plug of at least 15 m above the bridge plug of the uppermost perforation section.These plugs are not required if a bridge plug or a cement plug of at least 30 m is placed immediately above the debris at the bottom of the well bore and in cases where it is difficult to place the plugs due to debris at the bottom.
- D. If the casing is cut off and the upper part of the casing is removed, the well shall be sealed in one of the following ways:
 1. A cement plug of at least 30 m shall be placed immediately above the casing cut-off, or,
 2. A bridge plug shall be placed immediately above the casing cut-off.However, if the head of the casing cut-off is located below the casing shoe of the subsequent casing, the plugging method as described in B shall be applied.
- E. Near the surface, the well shall be sealed by a cement plug of at least 30 m. This plug shall be placed in the casing with the smallest diameter that reaches the surface. If, however, the open hole is not effectively isolated by cementing the annulus, the casing shall be cut off and pulled out. In

⁹ The original text was provided by METI (1986).

¹⁰ DISCLAIMER: The English version of this document is an unofficial translation. In case of discrepancy, the original Japanese text shall prevail.

that case, the well shall be sealed as described in D. In addition, a cement plug of at least 30 m shall be placed near the surface.

- F. If necessary, the wells shall be filled with mud or other fluids with sufficient specific density to raise the hydrostatic pressure to the formation pressure.
- G. The top plug, other than those extending above the surface, shall be tested by one of the following methods:
 - 1. Verifying that the pressure drop does not exceed 10% of the initial pressure over a period of 15 minutes, after pressurizing the plug by at least 3 MPa, or,
 - 2. Verifying that the plug retains its properties under a load of at least 3 tonnes.
- H. Casings and wellheads shall be removed to a depth of at least 2 m. In addition, the vicinity of the wellhead shall be covered with for instance cement, soil and sand.

Abandonment of wells producing natural gas dissolved in water

In general, cement plugs shall be made by using the replacement procedure with suitable cement.

The abandonment regulations are as follows:

- A. Wells shall be sealed immediately above perforated sections by a cement plug of at least 30 m. If free gases are generated, this plug shall be placed after filling the perforation section with mud. If the cement plug is used together with wooden plugs, the wooden plugs shall be placed immediately above the perforated section. A cement plug, of at least 30 m, shall be placed on top of these wooden plugs.
- B. Near the surface, the well shall be sealed by a cement plug of at least 30 m. If the well is completed using a gas lift process, the tubes shall be filled with cement.
- C. The wells shall be filled with mud or other fluids.
- D. The top plug, other than those extending above the surface, shall be tested by the following methods:
 - 1. Verifying the location of the top of the cement plug with a wire rope, and,
 - 2. Verifying that the pressure drop does not exceed 10% of the initial pressure over a period of 15 minutes, after pressurizing the plug by at least 1 MPa. In some cases it is, however, acceptable to confirm the quality of the plug through visual inspection that there is no loss or increase of mud or generation of bubbles after filling the well with water.
- E. Casings and wellheads shall be removed to a depth of at least 2 m. In addition, the vicinity of the wellhead shall be covered with for instance cement, soil and sand.

Appendix J United States of America

J.1 US EPA

The following text¹¹ contains the relevant topics from the US EPA Regulations on Plugging and Abandoning Injection Wells for Class II wells. Within region 5 Illinois, Indiana, Michigan, Minnesota, Ohio, Wisconsin and 35 tribes are served.

IV. Plugging and Abandonment (P&A) General Requirements

In order to prevent abandoned injection wells from becoming conduits for migration of injected fluids or natural brines vertically into an USDW, proper plugging is necessary. Either open casing or an uncemented annulus may provide such a conduit. In most Class I wells, each casing string is fully cemented to the surface when constructed. Many Class II wells have construction requirements which are not as stringent. Prior to abandoning injection wells, the well shall be plugged with cement in a manner which will not allow the movement of fluids into or between USDWs. To address these concerns, Region 5 has set standards which provide multiple layers of protection for all USDWs. Specific procedures outlined in this guidance may be varied upon approval by USEPA, Region 5.

The basic requirements for plugging and abandonment of any well are to plug in a manner so as to prevent movement of fluid out of the injection zone and into or between USDWs, and to:

- Notify the USEPA - Notification of the USEPA by the owner/operator is required at least 45 days prior to the commencement of plugging operations unless specified otherwise;
- Pass Part (2) of Mechanical Integrity - The well must have a current demonstration of part (2) of mechanical integrity pursuant to 40 C.F.R. § 146.8(a)(2) (no fluid movement behind pipe) as appropriate for the well classification; and
- Submit Plugging and Abandonment Report - The owner/operator must submit a plugging and abandonment report within 60 days after the well is plugged.

VI. Class II

Plugs are required in the well to protect all USDWs. The entire wellbore may be plugged with cement if all casing strings are cemented from their base to the surface. If any casing is not cemented entirely, casing less than 50 feet below the base of the USDWs must be removed. The injection zone, the cut/rip points, and the USDW must be plugged separately. Proper zone isolation will help to ensure that upward fluid migration will not occur.

- A. Notify the USEPA - Notification of the USEPA by the owner/operator at least 45 days prior to the commencement of plugging operations is required unless specified otherwise.
- B. Pass Part (2) of Mechanical Integrity - There must be a current demonstration of no fluid movement behind pipe, pursuant to 40 C.F.R. § 146.8(a)(2).
 1. Cementing Records - Cementing records or other evidence (such as cement bond logs) must show that there is an adequate quantity of cement to prevent upward fluid movement within the borehole outside of the casing; or
 2. Approved Tests or Logs - USEPA approved tests (such as Oxygen Activation, Temperature or Noise Logs) are current and demonstrate to the USEPA's satisfaction that there is no significant fluid movement into a USDW through vertical channels adjacent to the injection well bore.
- C. Removal of Debris - Removal of any downhole material and/or debris located above the injection zone is required. Region 5 requires that wells be opened and/or any obstruction be removed prior to commencing plugging. Tubing, packer, and any debris which remains in the well above the injection zone must be removed because it interferes with the proper plugging of a well. Normal

¹¹ The complete text is available at: http://www.epa.gov/r5water/uic/r5guid/r5_04.htm#iv

well entry may be impossible when injection wells have collapsed casing, collapsed bore holes, broken or stuck tubing, or debris obstructing the wellbore. Some wells have been abandoned for several years with tubing and packer left in the well, and in some cases, these wells contain tubing that has deteriorated to the point that normal retrieval is impossible. This equipment may be left in the well if alternate plugging methods which provide protection to USDWs are approved, if the cement is placed as close as possible to the injection zone and is within an interval of cemented casing in the confining zone. Approval by Region 5 will depend on well construction, geology, and area operations.

- D. Removal of Uncemented Casing - In most cases, all uncemented ("free") casing must be removed from the well. Where this is impossible because of deterioration of, or damage to casing, or collapsing of the hole, the following procedures should be followed:
1. Perforate Uncemented Casing - Perforate uncemented casing as low as possible, but at least 50 feet below the base of the lowermost USDW;
 2. Establish Circulation - Establish circulation through the perforations with a preflush (fresh water is preferred). Circulate the annulus with at least one hole volume of preflush until the flush circulates clean; and
 3. Squeeze Cement - Squeeze cement through the perforations into the well bore-casing annulus and circulate to surface using at least 120 percent of the required volume, or greater if necessary to achieve circulation of cement. The following cementing methods are acceptable:
 - a. The tubing squeeze method;
 - b. The tubing/packer squeeze method;
 - c. The bull plug method;
 - d. An alternative method approved by Region 5, which will reliably provide a comparable level of protection to USDWs. Alternatives will be considered only after the operator demonstrates that conventional attempts have been unsuccessful.
- E. Plugging and Cementing - The well is to be plugged with cement in a manner that prevents movement of fluids from the injection zone to the base of the lowermost USDW and into or between USDWs. The injection zone must be properly isolated so that no upward fluid migration will occur. Region 5 recommends that the injection zone be filled with cement. In all Class II wells, the top of each plug must be verified.
1. Isolation of Injection Zone - If an injection interval is not filled with cement, fluid flow from open perforations or open hole into the well may cause contamination of cement during plugging and abandonment. To eliminate the possibility of contamination in cases where injection zones produce significant amounts of fluid, Region 5 requires a mechanical plug to be set in order to control fluid movement and give the cement a good base for placement.

A combination of a Cast Iron Bridge Plug (CIBP) and cement plug will provide greater protection of USDWs. CIBPs may not properly pressurize or may experience problems such as deterioration over time, weak casing, burrs of metal, a malfunctioning equalizing pressure port, or incorrect gauging. If the CIBP moves due to pressure from the formation, fluid movement upward from the injection zone could result. Operators must meet the following requirements:

- a. Set a CIBP, cement retainer, or an alternative type plug or method, approved by Region 5, within cemented casing and within the confining zone to prevent fluid flow out of the injection zone and provide a sound base for the bottom cement plug;
- b. Set cement plugs on top of the mechanical plug;
 - i. If a cement retainer is used a minimum of 250 feet of cement must be set on top of it;

- ii. If a CIBP is used a minimum of 50 feet of cement must be set on top of it.

The operator must verify the location of all plugs to assure that plugs have not "fallen".

2. Protection at Cut/Rip Points - A minimum of 100 feet of cement is required across any point where casing is cut or ripped. This cement plug must extend from at least 50 feet below the rip point to 50 feet above the rip point. Casing should be cut or ripped as close to the top of the cement sheath outside the casing as possible. After casing is cut, the free casing must be removed from the well. See Attachment 2 to determine which method will be used to place the plug.
3. Protection of USDWs - The well is to be plugged with cement in a manner that prevents movement of fluid into or between USDWs. A cement plug must be placed from at least 50 feet below the base of the lowermost USDW to the surface to properly isolate USDWs. (Exceptions, as described below, are only allowable if the base of the lowermost USDW is more than 500 feet below the surface.)

In Michigan, (if approved by Region 5) a top and bottom plug may be used to isolate USDWs. If surface casing is cemented to surface and is set below the lowermost USDW, then the bottom USDW plug must extend from a point at least 50 feet below the surface casing shoe to at least 50 feet above the base of the lowermost USDW. If surface casing is cemented to surface and is not set below the lowermost USDW, then the bottom USDW plug must extend from a point at least 50 feet below the lowermost USDW to at least 50 feet above the surface casing shoe. The top plug must extend from a depth of at least 50 feet below the surface to the surface.

4. Surface Restoration - Casing should be cut off and the surface restored to its original condition in accordance with State requirements.
- F. Variation from Guidance - Specific procedures outlined in this guidance may be varied for unusual types of well construction, geologic conditions, or situations encountered during plugging and abandonment. The owner/operator must receive approval from Region 5 prior to plugging a well if varying from the procedures outlined in this guidance.

J.2 API

Here is an overview of API guidance (API, 1993):

1. The minimum cement plug length used for wellbore isolation is generally 100 ft (~ 30 m),
2. The cement plugs should extend 50 ft (~ 15 m) above and below the casing shoe or the zone being isolated (see Figure 8),
3. Where long intervals of impermeable zones exist, long uncased hole isolation may be achieved by setting a 100 ft plug at the top of the interval rather than isolating geologic horizons,
4. Plugging of perforated zones can be performed by the displacement method, squeeze cementing or a permanent bridge plug (see Figure 9).
5. Where the production casing is not cemented to surface, determine the top of cement behind the casing and identify critical intervals in the uncemented annulus.
6. Cement isolation plugs may be placed using drill pipe, workstring, coiled tubing, production tubing, or wireline tools. Plugging methods commonly used to isolate formation intervals are: balanced plug method, cement squeeze method, mechanical plugs and dump bailer method.
7. Class A, C, G, or H cements are typically used in well plugging operations.

8. The placement of critical plugs should be verified by tagging (i.e. lowering the drill pipe, (coil) tubing or work string onto the hardened plug and detecting a decrease in the weight of the drill pipe, (coil) tubing or work string).
9. Pressure testing of plugs, when required by regulatory agencies, can be done by swabbing (negative pressure differential) or by applying hydraulic pressure (positive pressure differential).

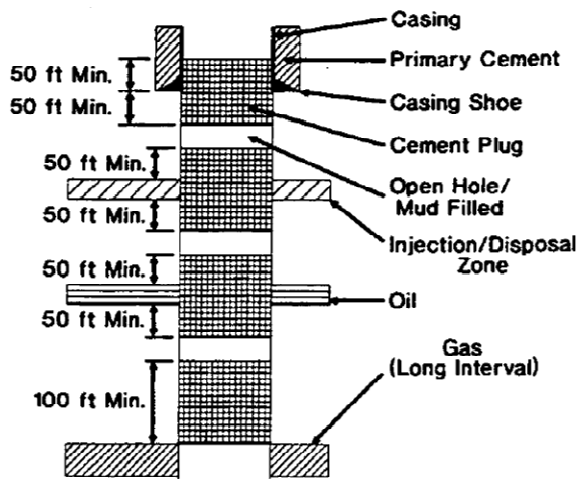

Figure 8 Isolation of zones in an uncased hole (API, 1993)

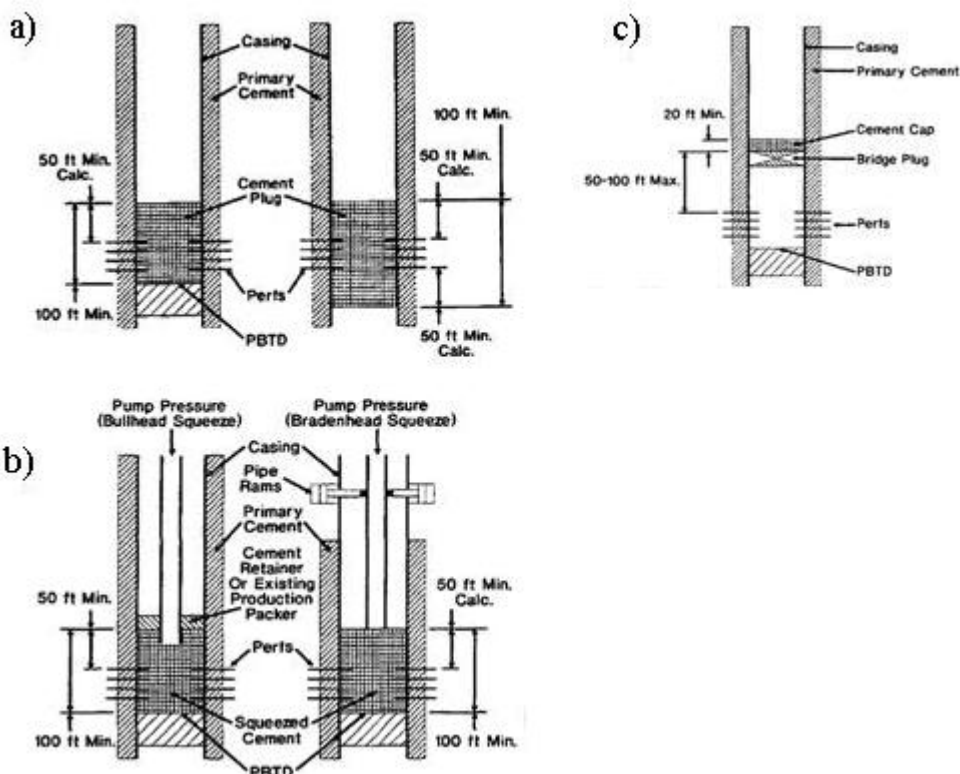

Figure 9 Plugging of perforated intervals (API, 1993) using a) the displacement method, b) squeeze cementing, c) a permanent bridge plug.

J.3 Alaska

The relevant Alaska Oil and Gas Conservation Commission regulations on well abandonment (The Alaska Administrative Code, 2009) are presented in this section.

20 AAC 25.112. Well plugging requirements

- a. Plugging of the uncased portion of a wellbore must be performed in a manner that ensures that all hydrocarbons and freshwater are confined to their respective indigenous strata and are prevented from migrating into other strata or to the surface. The minimum requirements for plugging the uncased portion of a wellbore are as follows:
 1. by the displacement method, a cement plug must be placed
 - A. from 100 feet below the base to 100 feet above the top of all hydrocarbon-bearing strata;
 - B. from the well's total depth to 100 feet above the top of all hydrocarbon-bearing strata;
 - C. from the well's plugged back total depth to 100 feet above the top of all hydrocarbon-bearing strata, if all hydrocarbon-bearing, abnormally geo-pressured, and freshwater strata below are isolated; however, the commission will approve plugging from the top of fill or the top of junk instead of from the plugged back total depth, if the commission determines that the objectives of this subsection will be met; or
 - D. from 100 feet below the base to 50 feet above the base of each significant hydrocarbon-bearing stratum and from 50 feet below the top to 100 feet above the top of each significant hydrocarbon-bearing stratum;
 2. by the displacement method, a cement plug must be placed from 100 feet below the base to 50 feet above the base of each abnormally geo-pressured stratum and from 50 feet below the top to 100 feet above the top of each abnormally geo-pressured stratum;
 3. by the displacement method, a cement plug must be placed from 150 feet below the base to 50 feet above the base of the deepest freshwater stratum.
- b. Plugging of a well must include effectively segregating uncased and cased portions of the wellbore to prevent vertical movement of fluid within the wellbore. The minimum requirement for plugging to segregate uncased and cased portions of a wellbore is one of the following:
 1. by the displacement method, a continuous cement plug must be placed from 100 feet below to 100 feet above the casing shoe;
 2. by the downsqueeze method using a retainer set no less than 50 feet but no more than 100 feet above the casing shoe, a volume of cement sufficient to fill the wellbore from the retainer to 100 feet below the casing shoe must be pumped through the retainer, and cement must be pumped above the retainer to cap it with a 50 foot cement plug;
 3. by the downsqueeze method using a production packer set no less than 50 feet but no more than 500 feet above the casing shoe, a volume of cement sufficient to fill the wellbore from 100 feet below the casing shoe to the packer must be pumped through the packer, and cement must be pumped above the packer to cap it with a 50 foot cement plug.
- c. Plugging of cased portions of a wellbore must be performed in a manner that ensures that all hydrocarbons and freshwater are confined to their respective indigenous strata and are prevented from migrating into other strata or to the surface. The minimum requirements for plugging cased portions of a wellbore are as follows:
 1. perforated intervals must be plugged by one of the following methods:
 - A. by the displacement method, a cement plug placed from 100 feet below the base to 50 feet above the base of the perforated interval and from 50 feet below the top to 100 feet above the top of the perforated interval;
 - B. by the displacement method, a cement plug placed from the well's total depth to 100 feet above the top of the perforated interval;
 - C. by the displacement method, a cement plug placed from the well's plugged-back total depth to 100 feet above the top of the perforated interval, if all hydrocarbon-bearing, abnormally geo-pressured, and freshwater strata below are isolated; however, the commission will approve plugging from the top of fill or the top of junk instead of from the plugged-back total depth, if the commission determines that the objectives of this subsection will be met;
 - D. by the downsqueeze method using a cement retainer or production packer set no less than 50 feet but no more than 500 feet above the perforated interval, a volume of

- i. The commission will, in its discretion, approve a variance from the requirements of this section if the variance provides for at least equally effective plugging of the well and prevention of fluid movement into sources of hydrocarbons or freshwater.

History: Eff. 11/7/99, Register 152

Authority: AS 31.05.030

J.4 California

The information in this appendix has been subtracted from section 1723 from the California Code of Regulations (DOGGR, 2006). 'Division' refers to the DOGGR from DOC. In addition, 'Supervisor' means the State Oil and Gas Supervisor.

Onshore

Plugging and abandonment operations can only start after notification of and agreement from the Supervisor. In general, cement plugs will be placed across specified intervals to protect oil and gas zones:

1. to prevent degradation of usable waters,
2. to protect surface conditions,
3. for public health and safety purposes.

The plugging and abandonment requirements for onshore wells can be summarized as follows:

A. Plugging of Oil or Gas Zones.

1. In an open hole, a cement plug shall be placed to extend from the total depth of the well or from at least 100 feet below the bottom of each oil or gas zone, to at least 100 feet above the top of each oil or gas zone.
2. In a cased hole, all perforations shall be plugged with cement, and the plug shall extend at least 100 feet above the top of a landed liner, the uppermost perforations, the casing cementing point, the water shut-off holes, or the oil or gas zone, whichever is highest.
3. Special plugging requirements may be made for particular types of hydrocarbon zones, such as:
 - a. Fractured shale or schist;
 - b. Massive sand intervals, particularly those with good vertical permeability;
 - c. Any depleted productive interval more than 100 feet thick; or
 - d. Multiple zones completed in a well.

As a minimum for an open-hole plugging and abandonment, the special requirement shall include a cement plug as defined in A1. As a minimum for a cased-hole plugging and abandonment, the special requirement shall include a cement plug as defined in A2 extending from at least 25 feet below the top of the uppermost perforated interval.

4. In a multiple zone completion, a single bridge plug above the lowermost zone may be allowed in lieu of cement through that zone if the zone is isolated from the upper zones by cement behind the casing. Subsequent bridge plugs are not allowed unless separated by cement plugs meeting the requirements of Section 1723.1(b) (DOGGR, 2006). Temporary bridge plugs must be removed and replaced with cement plugs prior to shallower zone completions or well abandonment.
5. When junk cannot be removed from the hole and fresh-saltwater contacts or oil or gas zones penetrated below cannot therefore be properly abandoned:
 - a. Cement shall be downsqueezed through or past the junk and a 100-foot cement plug shall be placed on top of the junk, or,
 - b. If it is not possible to downsqueeze through the junk, a 100-foot cement plug shall be placed on top of the junk.

B. Plugging for Freshwater Protection

1. Plugging in open hole requires:
 - a. A minimum 200-foot cement plug across all fresh-saltwater interfaces.

- b. An interface plug placed wholly within a thick shale if such shale separates the freshwater sands from the brackish or saltwater sands.
2. Plugging in a cased hole requires:
 - a. A 100-foot cement plug placed inside the casing across the interface, if there is cement behind the casing across the fresh-saltwater interface,
 - b. Squeeze-cementing through perforations to protect the freshwater deposits, if the top of the cement behind the casing is below the top of the highest saltwater sand. In addition, a 100-foot cement plug is required inside the casing across the fresh-saltwater interface.

The district deputy may require or allow a cavity shot immediately below the base of the freshwater sands. In such cases, the hole shall be cleaned out to the estimated bottom of the cavity and a 100-foot cement plug shall be placed in the casing from the cleanout point.

3. Where geologic or groundwater conditions dictate, special plugging procedures may be specified to prevent contamination of useable waters by downward percolation of poor quality surface waters, separate water zones of varying quality, and isolate dry sands that are in hydraulic continuity with groundwater aquifers.

C. Additional requirements

1. If the hole is open below a shoe, a cement plug shall extend from at least 50 feet below to at least 50 feet above the shoe. If the hole cannot be cleaned out to 50 feet below the shoe, a 100-foot cement plug shall be placed as deep as possible.
2. The hole and all annuli shall be plugged at the surface with at least a 25-foot cement plug. It may be required that inner strings of uncemented casing are removed to at least the base of the surface plug prior to placement of the plug.
3. All well casing shall be cut off at least 5 feet but no more than 10 feet below the surface of the ground. The district deputy may approve a different cut-off depth, as conditions warrant, including but not limited to excavation or grading operations for construction purposes.
4. A steel plate at least as thick as the outer well casing shall be welded around the circumference of the casing at the top of the casing, after Division approval of the surface plug. The steel plate shall show the well's identification, indicated by the last five digits of the API well number.

Offshore

Plugging and abandonment operations can only start after notification of and agreement from the Supervisor. The plugging and abandonment requirements for offshore wells can be summarized as follows:

1. In uncased portions of wells, cement plugs shall be placed to extend from total depth or at least 100 feet below each oil or gas zone, whichever is less, to at least 100 feet above the top of each zone. In addition, a cement plug at least 200 feet long shall be placed across an intrazone freshwater-saltwater interface or opposite impervious strata between fresh- and saltwater zones so as to confine the fluids in the strata in which they are found and to prevent them from escaping into other strata.
2. Where there is an open hole immediately below the casing, a cement plug shall be placed in the deepest cemented casing string from total depth or at least 100 feet below the casing shoe, whichever is less to at least 100 feet above the casing shoe.
3. Where there are perforated intervals, a cement plug shall be placed opposite all perforations extending to a minimum of 100 feet above the perforated intervals, liner top or cementing point, whichever is higher.
4. Inside cemented casing, a cement plug at least 100 feet long shall be placed above each oil or gas zone. In addition, above the shoe of the intermediate or second surface casing; a cement plug at least 200 feet long shall be placed across an intrazone freshwater-saltwater interface or opposite impervious strata between fresh- and saltwater zones.
5. If annular space that extends to the ocean floor is left open to the drilled hole below, a minimum of 200 feet of the annulus immediately above the shoe shall be plugged with cement.
6. When junk cannot be removed from the hole, and the hole below the junk is not properly plugged, cement plugs shall be placed as follows:
 - a. Sufficient cement shall be squeezed through the junk to isolate the lower oil, gas, or fresh water zones and a minimum of 100 feet of cement shall be placed on top of the junk, but no higher than the sea bed.

- b. If the top of the junk is opposite uncemented casing, the casing annulus immediately above the junk shall be cemented with sufficient cement to insure isolation of the lower zones.
7. If casing is cut and recovered, other than that pulled for placing the surface plug, a cement plug shall be placed from at least 100 feet below to at least 100 feet above the stub.
8. A cement plug at least 100 feet long shall be placed in the well with the top between 50 and 150 feet below the ocean floor. All inside casing strings with uncemented annuli shall be pulled from below the surface plug. The casing shall not be shot or cut in a manner that will damage outer casing strings and prevent re-entry into the well.
9. Any interval of the hole not plugged with cement shall be filled with mud fluid of sufficient density to exert hydrostatic pressure exceeding the greatest formation pressure encountered while drilling such interval.
10. Division tests for the location and hardness of cement plugs shall be verified by placing the total weight of the pipe string on the plug, or where there is sufficient depth, an open-end pipe weight of at least 10,000 pounds.
11. All casing and anchor piling shall be cut and removed from not more than 5 feet below the ocean floor, and the ocean floor cleared of any obstructions, unless prior approval to the contrary is obtained from the appropriate marine navigation and wildlife agencies and a copy of the approval filed with the Division.

J.5 Texas

Rule 3.14 from the Texas Administrative Code deals with plugging and well abandonment regulations (SOS, 2007).

Rule 3.14

A. General plug requirements

1. For onshore or inland wells, a 10 ft (~3 m) cement plug shall be placed in the top of the well, and casing shall be cut off three ft (~1 m) below the ground surface.
2. Mud-laden fluid of at least 9.5 pounds per gallon with a minimum funnel viscosity of 40 seconds must be placed in all portions of the well not filled with cement or other alternate material.
3. All cement plugs, except the top plug, must have sufficient slurry to fill 100 ft (~ 30 m) of hole plus 10% for each 1000 ft of depth from the surface to the bottom of the plug.
4. Cement plugs shall be placed by the circulation or squeeze method through tubing or drill pipe.
5. Only approved API cement should be used.
6. Additional cement plugs may be required to cover and contain any productive horizon or to separate water strata from each other if the water qualities or hydrostatic pressures differ sufficiently.

The following sections deal with the plugging requirements for different scenarios.

B. Wells with surface casing

1. Plugs must be set as necessary to separate multiple usable water quality water strata, by placing the plugs at each depth as determined by the Texas Commission on Environmental Quality or its successor agencies.
2. If sufficient casing has been set to protect all usable quality water strata, a cement plug must be placed across the shoe of the surface casing. The plug should be a minimum of 100 ft in length and must extend at least 50 ft above the shoe and at least 50 ft below the shoe.
3. If surface casing has been set deeper than 200 ft below the base of the deepest usable water quality stratum, a cement plug (minimum length of 100 ft) should be placed inside the casing and centred opposite the base of the deepest usable water quality stratum, which extends at least 50 ft above and at least 50 ft below the base this stratum.
4. If insufficient casing is set, both the plugs as defined in B2 and B3 should be placed.

C. Wells with intermediate casing

1. If the intermediate casing is cemented through all usable quality water strata and all productive horizons, a cement plug as specified in A3 should be placed inside the casing and centred opposite the base of the deepest usable water quality stratum. This plug should extend at least 50 ft above and 50 ft below the base of this stratum.
2. If the conditions in C1 are not met, and if the casing will not be pulled, the intermediate casing should be perforated at the required depths to place cement outside the casing.
3. Similar as B1.

D. Wells with production casing

1. If the production casing is cemented through all usable quality water strata and all productive horizons, a cement plug as specified in A3 should be placed inside the casing and centred opposite the base of the deepest usable water quality stratum and across any multi-stage cementing tool. This plug should extend at least 50 ft above and 50 ft below the base of this stratum.
2. If the conditions in D1 are not met, and if the casing will not be pulled, the production casing should be perforated at the required depths to place cement outside the casing.
3. An iron bridge plug may be placed (as long as the bridge plug can resist the surrounding conditions, i.e. temperature and pressure) immediately above each perforated interval, provided that at least 20 ft of cement is placed on top of each bridge plug.
4. Similar as B1.

E. Wells with screen or liner

1. If practical, the screen or liner should be removed from the well.
2. If the screen or liner is not removed a plug according to A3 should be placed.

F. Wells without production casing and open-hole completions

1. Any productive horizon or any formation in which a pressure or formation water problem is known to exist must be isolated by cement plugs (according to A3) centred at the top or the bottom of the formation.
2. If the gross thickness of any such formation is less than 100 ft, sufficient cement should be placed to fill the space between 50 ft below the base of the formation to at least 50 ft (plus 10% for each 1,000 ft of depth from the surface to the bottom of the plug) above the top of the formation.

G. Horizontal drainhole wells

1. All plugs should be placed according to A3.
2. If the production casing is set above the top of the productive horizon, the cement plug should be set from 50 ft below the top of the productive horizon to 50 ft above the production casing shoe.
3. If the production casing is set below the top of the productive horizon, the cement plug should be set from 50 ft below the production casing to a depth that is 50 ft above the top of the productive horizon.
4. Additional plugs may be placed according to A6.