



IEAGHG **Technical** Review
2019-TR02
November 2019

CO₂StCap (Cutting Cost of CO₂
Capture in Process Industry)

International Energy Agency

The International Energy Agency (IEA), an autonomous agency, was established in November 1974. Its primary mandate was – and is – two-fold: to promote energy security amongst its member countries through collective response to physical disruptions in oil supply, and provide authoritative research and analysis on ways to ensure reliable, affordable and clean energy for its 30 member countries and beyond. Within its mandate, the IEA created Technology Collaboration Programmes (TCPs) to further facilitate international collaboration on energy related topics. To date, there are 38 TCPs who carry out a wide range of activities on energy technology and related issues.

DISCLAIMER

The GHG TCP, also known as the IEAGHG, is organised under the auspices of the International Energy Agency (IEA) but is functionally and legally autonomous. Views, findings and publications of the IEAGHG do not necessarily represent the views or policies of the IEA Secretariat or its individual member countries.

This report was prepared as an account of the work sponsored by Gassnova (Climit), Energimyndigheten, IEAGHG, Global CCS Institute, Norcem AS, REC Solar AS, SSAB, AGA Gas AB, SINTEF AS, Chalmers University and Technology, University of South-Eastern Norway, RISE, and Swerim AB. The views and opinions of the authors expressed herein do not necessarily reflect those of the IEAGHG, its members, the organisations listed above, nor any employee or persons acting on behalf of any of them. In addition, none of these make any warranty, express or implied, assumes any liability or responsibility for the accuracy, completeness or usefulness of any information, apparatus, product of process disclosed or represents that its use would not infringe privately owned rights, including any parties intellectual property rights. Reference herein to any commercial product, process, service or trade name, trade mark or manufacturer does not necessarily constitute or imply any endorsement, recommendation or any favouring of such products.

COPYRIGHT

Copyright © IEA Environmental Projects Ltd. (IEAGHG) and CO₂stCAP project participants 2019. All rights reserved

ACKNOWLEDGEMENTS AND CITATIONS

This report describes the results obtained in the CO₂StCap project (Cutting Cost of CO₂ Capture in Process Industry), a research initiative led by SINTEF (2015-2019) and funded by the Norwegian CLIMIT-Demo programme via Gassnova and the Swedish Energy Agency. The CO₂StCap research partners were SINTEF, the University of South-Eastern Norway, Chalmers University of Technology, RISE, and Swerim AB. The industries involved were SSAB, Elkem AS, Norcem Brevik AS, and AGA Gas AB. IEAGHG and GCCSI supported the project.

The final report was prepared by:

- Fredrik Norman, Chalmers University of Technology
- Ragnhild Skagestad, SINTEF
- Maximillian Bierman, Chalmers University of Technology
- Jens Wolf, RISE
- Anette Mathisen, SINTEF
- Mikael Larsson, Swerim AB

The summary was prepared by the IEAGHG manager:

Monica Garcia Ortega

The report should be cited in literature as follows:

'IEAGHG, "CO₂StCap (Cutting Cost of CO₂ Capture in Process Industry), 2019-TR02, November, 2019.'

Further information or copies of the report can be obtained by contacting IEAGHG at:

IEAGHG, Pure Offices,
Cheltenham Office Park, Hatherley Lane,
Cheltenham,
GLOS., GL51 6SH, UK
Tel: +44 (0)1242 802911

E-mail: mail@ieaghg.org

Internet: www.ieaghg.org



CO₂stCap (Cutting Cost of CO₂ Capture in Process Industry)

Background

- The CO₂stCap project (Cutting Cost of CO₂ Capture in Process Industry), led by SINTEF, was a research initiative (2015-2019) funded by the Norwegian CLIMIT-Demo programme via Gassnova and the Swedish Energy Agency. The CO₂stCap research partners were SINTEF, the University of South-Eastern Norway, Chalmers University of Technology, RISE, and Swerim AB. The industries involved were SSAB, Elkem AS, Norcem Brevik AS, and AGA Gas AB. IEAGHG and GCCSI supported the project.
- The CO₂stCap project investigated CO₂ partial capture configurations for cement, pulp and paper, steel, and silicon for solar cells industries.
- The CO₂ capture technology investigated in this project was a MEA-based chemical absorption system, which includes an optimized rich-solvent splitting and absorber inter-stage cooling. The capture rates considered are dependent on the inputs of the specific cases, such as plant characteristics, CO₂ stacks, CO₂ concentration in the flue-gas to be treated, and supply of heat/energy.
- The CO₂stCap project contained a transparent cost assessment, which includes the capital and operational expenditures (CAPEX and OPEX) for retrofitting cases. The main cost metric used in this study is the CO₂ capture cost (€/tonne of CO₂ captured) and the main elements are described in detail.
- Steam generation for the CO₂ capture system was identified as a key cost element. The steam sources investigated were: steam produced from the excess heat; from a new boiler; and from a low-pressure bleed from existing steam cycles. Other key cost elements identified in this study are the plant lifetime and rate of return.
- The CO₂stCap project also investigated the use of biomass in different sectors and hydrogen in the steel industry.

Key Messages

- For the steel industry, the CO₂ capture rates assessed were from 19% to 76.3% of the total plant CO₂ emissions, by assuming single or combined CO₂ stacks. The costs are within the range 28-45 €/tonne CO₂-captured. The recovery of the available excess heat is key to achieving lower CO₂ capture costs.
- For the pulp and paper industry, the CO₂ capture rates assessed were from 66.5% to 74% of the total plant CO₂ emissions, by assuming combined stacks. The costs are within the range 41-54 €/tonne CO₂-captured. Capturing CO₂ from the lime kiln is more costly than that from the recovery boiler due to the lower volume of CO₂ emissions, even though it has a higher CO₂ concentration.
- For the cement industry, the CO₂ capture rates assessed were from 37% to 90%, all collected in a single stack. The costs are within the range 50-55 €/tonne CO₂-captured. These values take account of a low capture rate (37%) based on heat recovery from the



excess in the production plant, or investing in an additional steam boiler to achieve 90% of capture rate.

- For the silicon industry, the CO₂ capture rate assessed was 90% from a single stack. Due to the small CO₂ volume, and low CO₂ concentration, the cost of capture is 125-150 €/tonne CO₂-captured.
- The size of the CO₂ emissions source has the greatest impact on the full capture cost. This means that the cost of capture will be lower as the source becomes larger. Moreover, the sensitivity of the capture cost to energy prices is lower in partial capture cases than that in full capture cases.
- The impact of the CO₂ capture cost on the final industrial product could be assumed by the end-user, although it will depend on the competitiveness within the sector, profit margins, and the support from funding mechanisms or regulations.
- The use of biomass was investigated through a literature review. Four main concepts were analyzed: using biomass both as a substitute for fossil energy as well as fossil raw material (silicon and steel industries); and replacing the fossil energy needed for the industrial process (cement and pulp & paper) or just to provide energy for the capture plant (cement).
- Although the use of biomass appears as an attractive alternative in the literature, limitations on the use of biomass include cost, access and consistency of the original product quality. A significant substitution of fossil fuels and raw materials by biomass could increase the amount of energy and raw material needed, while changes in equipment and processes would also be needed.
- The use of hydrogen was investigated for the steel industry (based on the results from the HYBRIT project, with a 20% increase in the steel production cost and using the Direct Reduction Iron process, (DRI)).
- Other concepts investigated through the literature were the increase of energy efficiency and the use of renewable energy. The study concluded that the latter is strongly dependent on the region, it is still unpredictable, and the production and installation of renewables also has environmental impact.
- CO₂ utilization was explored through microalgae production in the silicon and cement industries. The cost of algae cultivation makes this application unfavourable.

Scope of Work

A capture rate above 90% is technically feasible and relatively cost-effective in some cases within the power production sector. However, in specific areas such as in process industries, this capture rate could imply an excessive cost, potentially due to the large amount of energy required, heat or steam demand, and the complex connections to capture the CO₂ from several CO₂ stacks.

The main objective of the CO₂stCap project was to investigate CO₂ capture at partial rates as a way to achieve significant CO₂ capture cost reductions at acceptable CO₂ emissions reduction levels. Partial CO₂ capture configurations can also be appealing for industrial plants to fulfil an Emission Performance Standard (EPS). Plants with multiple stacks and/or without access



to a storage site with enough capacity, plants where CO₂ capture can be combined with other mitigation strategies and/or with dynamic energy access or excess heat/energy available for a CO₂ capture system, and projects where a reduced capture rate would mean a reduction of the investment risk could be envisaged.

The CO₂stCap project focused the research on the following industries: cement, pulp and paper, steel and silicon for solar cells, as described in Table 1. The pathways investigated were: integration of the CO₂ capture system within a dynamic energy system; use of partial capture rate; and the use of biomass.

Table 1 Description of the plants considered in CO₂stCap (Source: CO₂stCap *core report*)

Industry/CO₂ stacks	CO₂ emissions (Mt/y)	CO₂ concentration (%)	Production in year 2016
Steel mill			
- Power Plant	1.91	30	2 Mt steel slabs/y max. 97 MW of electricity
- Blast Furnace Gas	1.42	25	
- Hot Stoves	0.73	25	
Cement			
- Stack	0.84	15	1.2 Mt cement/y
Pulp Plant			
- Recovery boiler	1.26	21	700,000 ADt pulp/y, 67 MW of electricity
- Lime kiln	0.21	30	
- Power boiler	0.13	19	
Silicon			
- Stack	0.055	1	10 kt silicon metals/y

Conclusions

The CO₂stCap project has investigated the techno-economic impact of the CO₂ source (CO₂ concentration, and size), heat supply, and seasonal/hourly variations on CO₂ capture systems integrated in four industries: cement; pulp and paper; steel; and silicon for solar cells. Based on the results, tailoring the carbon capture system to the specific conditions of the production facility is key to achieving cost-effective systems.

The optimization of a partial CO₂ capture configuration in the industrial sector could be enhanced by assuming potential capture rates that combine low value heat, equipment designed



for an average production scenario instead of peak production, and by targeting the most favourable CO₂ sources and / or a specific emissions limit. If a discontinuous capture scenario is considered, the capture plant could operate when the economic conditions are most favourable, such as when cost variations are beneficial during specific periods during the day/night or seasons.

Within the industries studied, cement, pulp and paper, steel and silicon for solar cells, the results of the CO₂stCap project showed the lowest CO₂ capture costs in arrangements applied to the steel and cement industries. Using available excess heat and low-pressure steam in the CO₂ capture system shows a range cost of 40-70 €/CO₂ captured for these sectors.

Recommendations

The CO₂stCap project has explored a different CO₂ capture strategy for the industrial sector, based on partial capture rates. It is recommended that IEAGHG should continue to maintain a watching brief of CO₂ capture technologies, systems and configurations for the industrial sector as part of the decarbonising tools portfolio.

Based on the results from the CO₂stCap project, and recent IEAGHG technical reports (e.g. IEAGHG 2019-09, and IEAGHG 2018-TR 03), it is recommended that partial capture arrangements based on alternative CO₂ capture technologies should be explored. These are technologies that are different to MEA-based chemical absorption. It is recommended to compare those to the new IEAGHG benchmark CO₂ capture technology (advanced configuration of chemical absorption with 40w.t. % of piperazine (PZ)+ 2-amino-methyl-1-propanol (AMP)).

In addition, while the CO₂stCap project has provided a deep insight about the integration of CO₂ capture technologies in the Scandinavian industry, it is recommended that options that incorporate a broader geographical context, which should include the peculiarities of the electricity grid such as the carbon insensitivity factor, and the potential heat integration and CO₂ utilization within a local framework, should be explored.

CO₂stCap

Reducing the Cost of Carbon
Capture in Process Industry

Final report

The CO₂stCap Project

Reducing the Cost of Carbon Capture in Process Industry

Final report

Authors:	Affiliation:	Contact:
Fredrik Normann	Chalmers University of Technology	Fredrik.Normann@chalmers.se
Ragnhild Skagestad	SINTEF	Ragnhild.Skagestad@sintef.no
Maximillian Bierman	Chalmers University of Technology	Max.Biermann@chalmers.se
Jens Wolf	RISE	Jens.Wolf@ri.se
Anette Mathisen	SINTEF	Anette.Mathisen@sintef.no

For general questions, contact:

Ragnhild Skagestad, SINTEF, (Project Manager) or
Fredrik Normann, Chalmers.

For topic specific questions, contact:

Max Biermann, Chalmers, on Steel industry,
Jens Wolf, RISE, on Pulp and Paper industry,
Anette Mathisen, SINTEF, on Cement and Silicon industry, and
Ragnhild Skagestad, SINTEF, on Cost estimation.

Porsgrunn, 28.08.2018

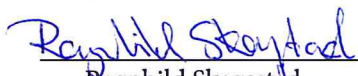
Ragnhild Skagestad
Project Manager

Published by: Chalmers University of Technology
Göteborg, Sweden, 2019

This project is funded by Gassnova (Climit), Energimyndigheten, IEAGHG, Global CCS Institute, Norcem AS, REC Solar AS, SSAB, AGA Gas AB, SINTEF AS, Chalmers University and Technology, University of South-Eastern Norway, RISE, and Swerim AB.

Introduction

The CO₂stCap-Project is a Norwegian-Swedish research initiative that was initiated in Year 2015 to reduce the cost of carbon capture in the process industry by developing concepts for the partial capture of emissions. The project is based on the premises that carbon capture and storage (CCS) is commercially available and can be implemented on a large scale, and that CCS is a required part of the solution to reduce global emissions of CO₂ in line with the 1.5°C target. However, the substantial efforts made to develop low-carbon technologies have resulted in little implementation, as the value assigned to mitigating CO₂ emissions is still too low relative to the risk associated with the considerable investment required, both from the industry and societal perspectives. The CO₂stCap-Project is designed to enable the goals related to the reduction of CO₂ emissions that have been established at the national, regional and global levels.

The CO₂stCap-Project focuses on four industrial processes that have process-related emissions of CO₂, i.e., emissions that are not only from heat supply but also part of the manufacturing process. Such emissions are likely to require CCS, as they are difficult to reduce through measures such as fuel-shifting, electrification, and energy efficiency improvements. *Steel making* accounts for 5% of the global energy-related greenhouse gas (GHG) emissions [1]. When it follows the blast furnace route it requires coal, which generates CO₂, for the reduction of the iron ore. *Cement production* accounts for 7% of the global energy-related GHG emissions [1]. In addition to the emissions from the generation of the required process heat, there are CO₂ emissions from the calcination of calcium carbonate to calcium oxide, which is an essential component of cement clinker. *Silica manufacturing* is dependent upon the use of carbon electrodes to reduce the silicon oxide to silica. In this reduction, the carbon electrodes are consumed, and the CO₂ formed is emitted. *Pulp making* results in sizeable waste streams of biomass that cannot be used for making pulp. These streams, which include the bark and lignin, are combusted onsite for heat and power generation, resulting in considerable CO₂ emissions. Although these emissions are not of fossil origin, they nevertheless constitute an important source of CO₂ emissions that the present pulp-making process cannot avoid. If these emissions are captured negative emissions can be achieved, which could be used to offset emissions from the combustion of fossil fuels in those applications in which CCS is difficult or expensive to implement.

The CO₂stCap-Project is a research collaboration between the Norwegian partners of SINTEF and the University of South-Eastern Norway and the Swedish partners of Chalmers University of Technology, RISE, and Swerim AB. The work is performed in close collaboration with partners of the concerned industries: SSAB, Elkem, Norcem Brevik AS, and AGA Gas AB. International NGOs, including both IEAGHG and GCCSI, have also supported the project, and financial support has been provided by CLIMIT and the Swedish Energy Agency. The outcomes of the project have been presented on an ongoing basis through conference and journal publications. This report summarizes and presents the major conclusions of the project. First, four stories are presented to exemplify how partial capture may come into play based on the outcomes of the project. These stories are followed by a summary of the results. More detailed information on the methodologies and studies performed may be found in the publications related to the project, which are presented in Table 1.

List of Publications

Table 1. Publications related to the CO₂stCap Project.

Title	Main Author	Name of the periodical	Year	Keywords
Excess heat-driven carbon capture at an integrated steel mill – considerations for capture cost optimization	Biermann, Maximilian	Submitted for publication	2019	Steelmaking, Process integration, Cost estimation
Integrating carbon capture into an industrial combined-heat-and-power plant: performance with hourly and seasonal load changes.	Martinez Castilla, Guillermo	International Journal of Greenhouse Gas Control	2019	Steel making, Process integration, Process dynamics
Cost estimation of CO ₂ absorption plants for CO ₂ mitigation – method and assumptions	Ali, Hassan	International Journal of Greenhouse Gas Control	2019	Cost estimation
Steam production options for CO ₂ capture at a cement plant in Norway	Ali, Hassan	Greenhouse Gas Control Technologies Conference, Melbourne	2019	Cement, Steam generation, Cost estimation,
CO ₂ capture scenarios for a cement plant	Mathisen, Anette	Submitted for publication	2019	Cement, Process integration
CO ₂ capture opportunities in the Norwegian silicon industry	Mathisen, Anette	Submitted for publication	2018	Silicon
Partial carbon capture by absorption cycle for reduced specific capture cost	Biermann, Maximilian	Industrial and Engineering Chemistry Research	2018	Process design, Cost estimation
Cost estimation of heat recovery networks for utilization of industrial excess heat for carbon dioxide absorption	Hassan, Ali	International Journal of Greenhouse Gas Control	2018	Process integration, Cost estimation
Simulation and economic optimization of amine-based CO ₂ capture using excess heat at a cement plant	Hassan, Ali	Linköping Electronic Conference Proceedings	2018	Cement, Cost estimation, Process integration
Evaluation of steel mills as carbon sinks	Biermann, Maximilian	International Conference on Negative CO ₂ Emissions	2018	Steel making, Negative emissions
Evaluation of low and high level integration options for carbon capture at an integrated iron and steel mill	Sundqvist, Maria	International Journal of Greenhouse Gas Control	2018	Steel making, Process integration
Investment costs and CO ₂ reduction potential of carbon capture from industrial plants – A Swedish case study	Gardarsdottir, Stefania	International Journal of Greenhouse Gas Control	2018	Review, Cost estimation
Partial capture of carbon dioxide from industrial sources - a discussion of cost optimization and the CO ₂ capture rate	Normann, Fredrik	Energy Procedia	2017	Review Cost estimation
CO ₂ stCap - cutting cost of CO ₂ capture in process industry	Skagestad, Ragnhild	Energy Procedia	2017	Review, Cost estimation
Simulation and economic optimization of vapor recompression configuration for partial CO ₂ capture.	Øi, Lars	Linköping Electronic Conference Proceedings	2017	Process design, Cost estimation

Table of Contents

Introduction	II
List of Publications	III
Four Stories of Partial Capture	V
<i>Steel – utilizing the window of opportunity</i>	<i>V</i>
<i>Cement – putting the extra heat to work</i>	<i>VI</i>
<i>Silicon – enabling a carbon-neutral solar cell</i>	<i>VII</i>
<i>Pulp – converting negative emissions into a valuable product</i>	<i>VIII</i>
The Concept of Partial Capture	9
Methodology of the CO₂stCap-Project	10
Case Studies	14
<i>Steel</i>	<i>14</i>
<i>Pulp and Paper</i>	<i>16</i>
<i>Cement</i>	<i>19</i>
<i>Silicon</i>	<i>21</i>
Results	23
<i>System Impacts of Partial Capture</i>	<i>23</i>
<i>Cost of Steam Generation</i>	<i>24</i>
<i>Cost Structure of Partial Capture</i>	<i>25</i>
Conclusion	27
References	28

Four Stories of Partial Capture

Steel – utilizing the window of opportunity

Carbon neutrality is a special challenge for steel given that carbon is not only an energy source, but is also the most widely used reducing agent for reducing iron ore to iron. The Swedish iron and steel industry has a well-defined roadmap for realizing carbon-free steel production using hydrogen as a reducing agent for direct reduction of iron ore and electricity as an energy supply and for hydrogen production. This initiative, led by the Hybrit-Project, has the aim of making the SSAB Luleå plant carbon-neutral by Year 2045 [2]. This means that there is about 30 years, or one to two investment cycles (relining of the blast furnace refractory), left to follow the blast furnace production route before it should be replaced by a novel, carbon-free production technique. Figure I illustrates the time plan and the possible investment cycles of the SSAB Luleå plant until Year 2050, and relates it to a projection for the development of the carbon price for the same time period.

At present, the cost for emitting one tonne of CO₂ under the EU-ETS is approaching 30 €. The estimated partial capture cost, including ship transportation and storage costs, is about double this level (40–60 €/tonne CO₂), while full capture would require a carbon price approaching 80 €/tonne CO₂. Under policies that value carbon emissions, partial capture may be economically viable already in the early 2020s, allowing for around 25 years of operation to secure payback of the investment in a capture unit. With the plan to replace the blast furnace route by Year 2045, this window of opportunity for partial capture is closing rather quickly if the pace of carbon price increases or investment decisions is too slow. A carbon price that motivates a much higher degree of capture is not likely to appear before alternative technologies that are more suitable for high levels of decarbonization are available. At the earliest, direct reduction with hydrogen is expected to reach technical and economical maturity after Year 2030 [3] and Year 2040 [4], respectively.

In summary, as a mature and low-cost technology, partial capture has a time-window for implementation in the coming 5–15 years for operation in the coming investment cycle for the blast furnace. Early implementation of partial capture would initiate a large-scale reduction of CO₂ emissions and decrease the risk of other technologies failing to arrive on time and at sufficient scale to meet reduction targets, while reducing the accumulated emissions during the developmental phase of the carbon-neutral process. Furthermore, partial capture may evolve towards carbon-neutral steelmaking over time through technology developments onsite (i.e., the learning curve for energy efficiency, solvent improvement, and additional capture units) and may be utilized also for carbon-neutral steel production in combination with other measures, such as biomass utilization and electrification.

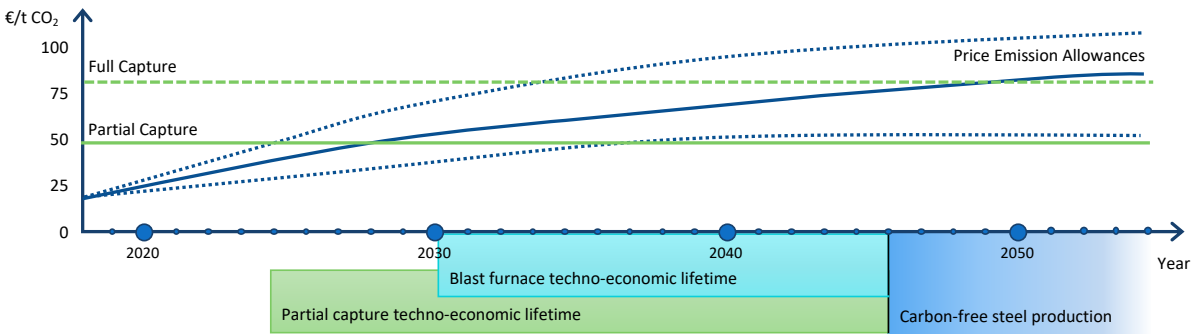

Figure I. Relationship between a possible plan for investment cycles in the SSAB Luleå steel mill towards carbon-free steel production projection in Year 2050 and a projection for the value of carbon emissions allowances for the same time period (blue line, with levels of uncertainty indicated by the dotted lines). The green lines indicate the CCS costs for partial (full line) and full (dotted line) capture.

Cement – putting the extra heat to work

Calcium carbonate, or limestone, is the main raw material for cement. The first step in the manufacture of cement is to calcinate the calcium carbonate, which releases CO₂, to form the calcium oxide needed to yield cement clinker. Around 60% of current CO₂ emissions from the cement industry is from calcination and, thus, not related to the use of energy and fossil fuels. CCS is the only way to have on-site mitigation of the CO₂ emissions from the calcination process. The calcination process requires temperatures >825°C, and the outlet gases from the process contain a considerable amount of heat that could be used internally, for pre-heating or drying processes, or externally if converted to an energy product, such as electricity or district heating.

Figure II illustrates the present-day situation regarding CO₂ emissions and access to excess heat at the Norcem plant in Brevik, Norway. Owing to special circumstances and market conditions, the owners of Norcem have never experienced an incentive to utilize their excess heat, which means that they have an unusually large capacity of excess heat that could generate steam of the quality required to power a carbon capture process. The estimated cost of installing and operating a heat-recovery steam generator to recover this heat is around 2 €/tonne steam or around 10% of the cost of steam from a dedicated onsite steam boiler. As the steam requirement represents the major part of the capture cost, the excess heat would reduce considerably the costs of operating the capture plant. The cost of partial capture, to a degree corresponding to the amount of recoverable heat, is around 45 €/tonne CO₂. The capture of CO₂ creates an incentive to utilize the excess heat at the cement mill.

Partial capture fits well with the Norcem strategy to work consistently to introduce novel and renewable fuels and electrification of the process, so as to cover the energy demand. Currently, the heat is sufficient to capture the CO₂ released during the calcination process. However, in the long term, when more or all fossil fuels will be replaced, the partial capture process will make the cement production CO₂-neutral by capturing the CO₂ released from the calcium carbonate.

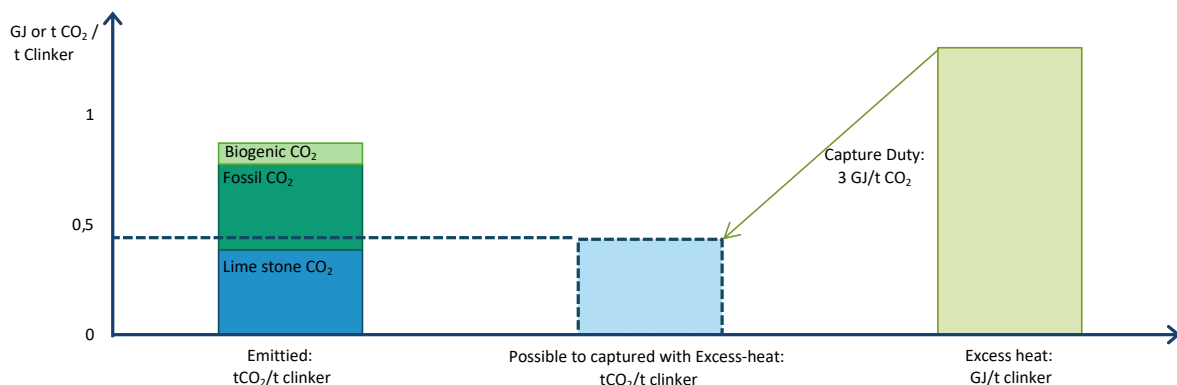

Figure II. Amount of CO₂ that can be captured by utilizing the excess heat available in the flue gas stream of the Norcem cement plant in Brevik. The remaining fossil carbon emissions could be mitigated using other options, such as increasing the share of biogenic fuel or electrification, or by decreasing the capture duty to capture a larger share of the emissions.

Silicon – enabling a carbon-neutral solar cell

The production of solar cells for CO₂-free power generation has expanded exponentially over the last few years – mainly because the cost of manufacturing prices has decreased, but also because of increased awareness of global warming and a public willingness to favor carbon-neutral power generation. Thus, the ability to offer a carbon-neutral solar cell may confer a market advantage on a solar cell manufacturer. Besides the emissions linked to energy and transport needs, carbon is used in the production of the silicon required to manufacture solar cells. The use of carbon electrodes in submerged electric arc furnaces reduces the quartz (SiO₂) to the silicon metal that is used to construct solar cells. The formation of at least 3.4 kg CO₂ per kg of silica is, thus, an inevitable part of the manufacturing process.

The REC Solar plant in Kristiansand, Norway, produces around 10 kt of silicon and emits 55 kt of CO₂ per year, of which 20% is biogenic, for the manufacture of solar cells. The site emissions are relatively small and diluted, which means that they are not ideal for carbon capture. Even though the REC Solar plant is presently not utilizing its warm off-gases from the electric arc furnace, which could provide more than enough heat to power capture of the full site emissions, the capture cost at REC Solar is around 100 €/tonne CO₂ with the present production process. The price for CO₂ emissions allowances is not likely to reach these levels in the near future. However, the special market drive of the end-product creates an extra value that may bridge the gap between the price of the emissions allowance and the capture cost, thereby motivating already today an investment in a carbon capture plant.

Figure III shows an approximate breakdown of the cost of a crystalline silicon photovoltaic module. The difference between the capture cost and emission allowance cost would make the silica produced by a plant equipped with carbon capture around 25% more expensive than the current production cost. In turn, supplying carbon-neutral silicon to Si-wafer manufacturing would mean an increase in the cost of final PV-module of less than 5%, which is much less than the regional differences seen for the production prices of solar cell modules, which may be as large as 30% [5]. In addition, the cost of the PV-module only makes up 30%–60% of the final solar plant installation. The value for the final solar panel in branding the silica as being manufactured in a carbon-neutral fashion may motivate the investment in a small-scale carbon capture plant. An early investment in carbon capture ensures a share of the demand for carbon-neutral silicon, while decreasing sensitivity towards upcoming increases in the price of emissions allowances.

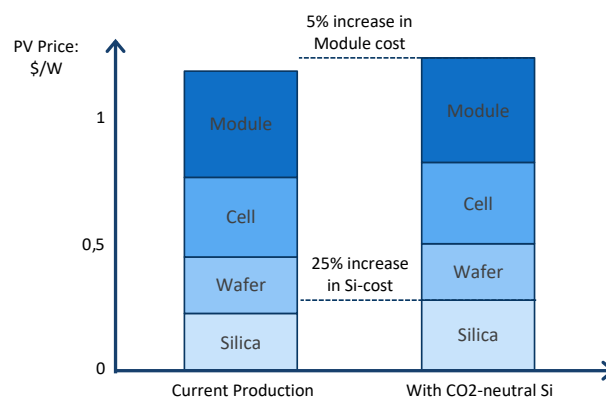

Figure III. Cost breakdown of a crystalline silicon photovoltaic module. If the implementation of carbon capture increases the silica cost by 25% the cost of the PV module will increase by around 5%. The cost breakdown is based on the work of Goodrich et al. [5]. Note that measures other than CO₂-neutral silica production are required to make carbon-neutral PV modules.

Pulp – converting negative emissions into a valuable product

The large Swedish pulp mills emit around 20 Mt CO₂ annually, distributed over only 20 sites. Figure IV relates the emissions from the pulp mills to the total Swedish annual emission of around 50 Mt CO₂ of fossil origin (17 Mt from industry and 17 Mt from the transport sector). The emissions from the pulp mills arise from combustion that covers the internal energy requirement of the pulp and paper mill and, to varying degrees, for external energy use through conversion to (mainly) electricity, although in some cases also to district heating and fuels. The emissions from the pulp and paper mills are of biogenic origin, as they come from the combustion of residual biomass that cannot be made into pulp. Thus, the carbon emissions from pulp mills are not obliged to be covered by emissions allowances. However, it is in Society's interest to optimize the value and climate effect of the biomass resource used in pulp mills. For example, current generation of electricity for external use from the mill is exempt from carbon tax and supported by the green certificate system for renewable power generation, so as to make it profitable for the plant owner to invest in power generation.

Another way to utilize the residual biomass after the manufacture of pulp is to use the energy to power a carbon capture process that would achieve net-negative emissions at the site, thereby allowing one to offset emissions from harder-to-abate sectors, in which low-carbon technologies are expensive or unavailable, or in the future to remove CO₂ from the atmosphere. The mills are highly suitable for carbon capture, as much of their emissions is collected in the stack of the recovery boiler and they have steam generation and a steam turbine already in place at the site. In the example of the pulp mill in the present report, halving the electricity output by using low-pressure steam from the steam turbine to power the carbon capture process allows for the capture of 80% of the emissions from the recovery boiler (65% of the plant emissions) at a cost of around 45 €/tonne CO₂ (based on current power prices).

As biomass is considered to be a carbon-neutral energy source, mechanisms for crediting the emission of CO₂ from biomass are lacking. To exploit the potential of carbon capture from biogenic sources in general, and from pulp mills in particular, the emitted or captured CO₂ must be assigned a value. One way, which is often proposed, is to regard the captured emissions from a biogenic source as “negative”. In this way, the amount of CO₂ captured could be allowed to generate emissions allowances under the ETS, which at present is approaching a value of 30 €/tonne, or to offset emissions from, for example, transportation fuels so to decrease their carbon tax, which at present is valued at around 100 €/tonne in Sweden and at around 200 €/tonne in Norway. The importance of creating a value for efficient use of the biomass resource is illustrated by the system of issuing green certificates for renewable electricity generation, which has motivated investments in efficient steam cycles at the mills. In a similar way, having a value for CO₂ emissions instead of renewable electricity generation from biomass could motivate investments in partial carbon capture.

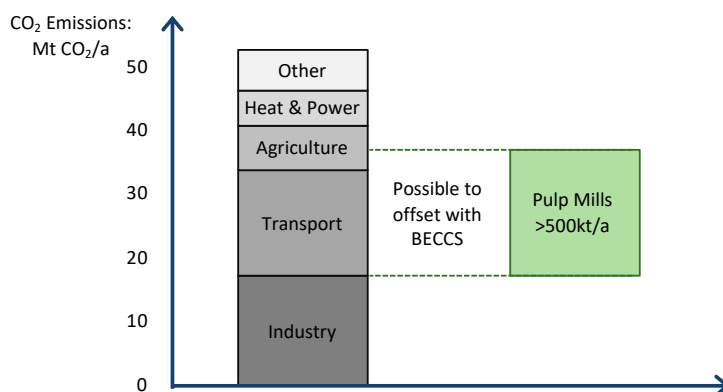

Figure IV. Total Swedish CO₂ emissions (CO₂-equivalents) of fossil origin [6] and total emissions from Swedish pulp mills that have an annual emission level of 500 kt or more [7], to illustrate the considerable quantity of carbon emissions that it is possible to offset using bio-energy with carbon capture and storage (BECCS).

The Concept of Partial Capture

To define partial capture, it is first necessary to define full capture. In this work, we define *full capture*, which is the goal of the majority of the carbon capture schemes presented in the literature, as the highest CO₂ capture rate that is technically feasible, usually corresponding to capture rates >90% from a CO₂-rich gas. When applied to a conventional CO₂ source (typically a coal-fired power plant) with access to heat from a steam cycle, a high capture rate will lower the specific capture cost and be beneficial to the plant owner (given that the penalty for emitting CO₂ is higher than the cost of capture). In practice, the lowest specific capture cost is found in the range of 85%–96% for coal-fired power plants [8]. Studies on CCS in the process industry commonly apply a capture rate of 90% [9]. However, in many industries, depending on the conditions associated with the CO₂ source and the onsite energy system, a high capture rate may imply excessive costs, which even increase the specific capture cost. We define *partial capture* as a carbon capture concept in which only a share of the accessible CO₂ from a flue gas or process gas is captured, with the extent of this share being governed by economic factors, such as energy prices, and policy-driven requirements. In all cases, partial capture reduces the absolute energy penalty and the size of the required investment. The following examples illustrate those scenarios in which partial capture may be preferred over full capture:

- Plants that have an energy system that continuously produces or generates depending on market conditions part of the heat needed for carbon capture at low cost.
- Plants that are regulated by an Emission Performance Standards (EPS), requiring capture rates that are lower than full capture.
- The possibility to reduce investment risks related to CCS deployment due to lower investment costs.
- For plants with multiple stacks, targeting the most suitable stack(s) instead of the total site emissions.
- Sites where the capacity of the adjacent storage facility is insufficient for the storage of all the CO₂ emitted during its lifetime.
- Plants in which carbon capture is cost-efficient when used in combination with other mitigation measures.

Methodology of the CO₂stCap-Project

The concept of partial capture is investigated for four case studies by performing cost optimization calculations for a monoethanolamine (MEA) absorption-based capture process. Figure 1 provides a schematic overview of the method used. The investigation is based on detailed process simulations using the modeling tool Aspen Plus to design and size the capture unit. The process models used have been presented in previous publications [10, 11]. The process design was established through an iterative process, which included a techno-economic analysis to develop cost-efficient capture processes. The cost estimation is performed with the Aspen In-plant Cost Estimator, combined with a well-proven, in-house-developed cost factor model (see for example [12, 13]). Different capture rates are considered depending on the inputs of case-specific plant characteristics, such as the number and physical locations of the flue gas stacks (CO₂-sources), the CO₂ concentration, possible options for heat supply, and the availability of excess heat. In addition, the effects of site-specific cost data (available utilities, geographic location, plant capacity and operation) and interactions with energy markets with seasonal dependencies in relation to district heating demand and volatile electricity prices (e.g., from variable power generation) are discussed.

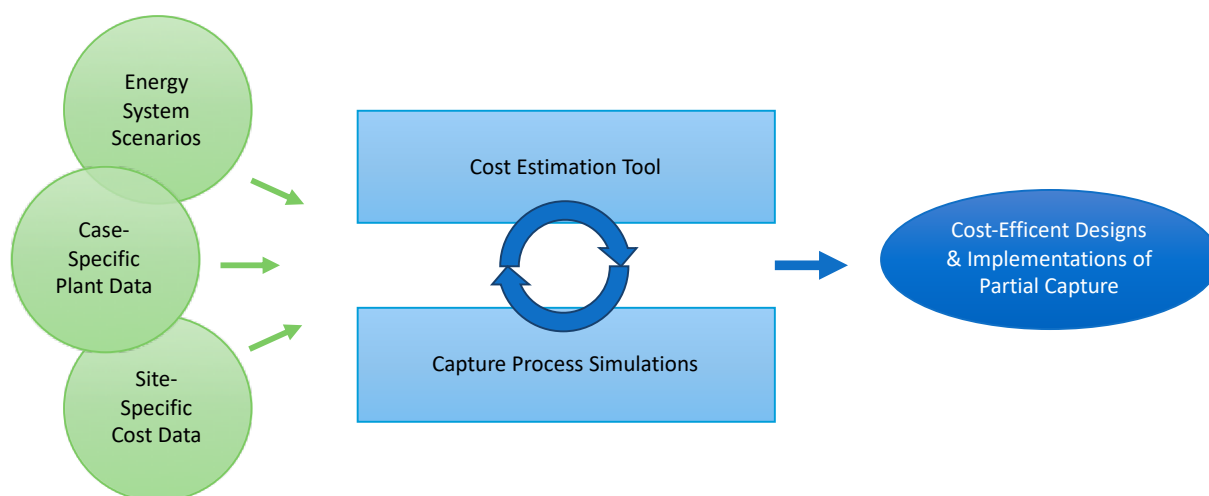

Figure 1. Schematic overview of the methodology used in the CO₂stCap Project

Carbon Capture Process Model

In line with the scope of this work, namely the near-future deployment of partial capture, amine absorption, which is an off-the-shelf technology, was chosen as the primary capture technology. Although many proprietary amine solvents with better performance characteristics are commercially available, the MEA solvent provides results that are directly comparable with the results from other studies. Various configurations of the amine capture process have been proposed for full capture, aimed at reducing the energy penalty linked to the temperature swing for regeneration of the solvent. A process flow diagram of the capture unit is illustrated in Figure 2. Besides the simple absorption cycle, this work considers absorber rich-solvent splitting and absorber inter-stage cooling. Optimization of the absorber design is described in detail by Biermann et al. [11].

The chemical absorption process and the rich-solvent split-flow configuration were simulated in the Aspen Plus ver. 8.8 software. Simulations of the designs and operating conditions are performed to optimize the MEA capture process with respect to energy use, applying a rate-based approach. The performance of the carbon capture process is the result of a combination of stripper pressure, CO₂ loading, solvent concentration, and the split fraction, which were identified as important design parameters in previous studies [14-16]. These parameters were optimized with respect to the specific reboiler duty (MJ per unit of CO₂ captured), in conjunction with the cost estimation.

Saturated steam at 3 bar (~133°C) is required to provide the heat needed to power the regeneration of the solvent at 120°C. Possible sources of this steam are identified for each reference plant, and the resulting steam supply configurations are evaluated with respect to their cost efficiency.

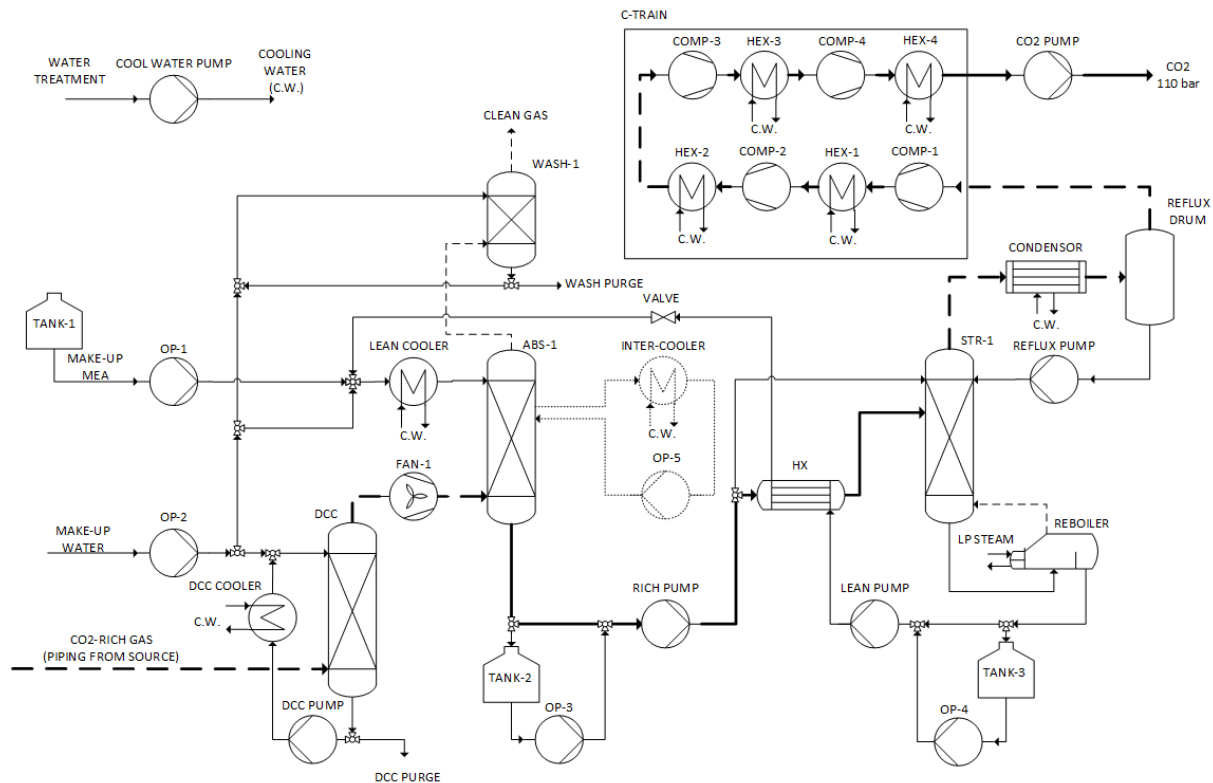

Figure 2. Illustration of a process flow diagram of the capture unit. The included equipment represents the scope of the cost estimations in the present study. The dashed lines indicate absorber inter-stage cooling, which is deemed to be specific for the steel industry case.

Industrial cases

Previous work on industrial capture has shown clearly that there are considerable differences between the conditions for capture at different industrial sites. Thus, great care is taken to map the site conditions for the four industrial cases. The evaluation is carried out in collaboration with the concerned industries and includes evaluations that employ in-house modeling tools to consider the effect of implementation of the carbon capture unit on the operation of the main process. Table 2 gives an overview of the specifications of the emission sources. The site-specific models for the industrial cases, as well as the model for estimating the cost of steam generation are described below.

Table 2. Characteristics of the point sources considered in the CO₂stCap-Project.

Industry / Point sources considered	Quantity (Mt CO ₂ /a)	Quality (vol.% CO ₂)	Production (Year 2016)
Steel mill			
Power plant	1.91	30%	2 Mt steel slabs/a, max. 97 MW of electricity
Blast Furnace Gas ¹	1.42	25%	
Hot Stoves	0.73	25%	
Cement			
Stack	0.84	15%	1.2 Mt cement/a
Pulp plant			
Recovery boiler	1.26	21%	700 000 ADt pulp/a, 67 MW of electricity
Lime kiln	0.21	30%	
Power boiler	0.13	19%	
Silicon			
Stack	0.055	1%	10 kt silicon metals/a

¹Note that the BFG is not a direct emission point source, but rather a process gas used for heating purposes.

Steel

An integrated iron and steel system model with mass and energy balances over the production process, including a blast furnace with accompanying hot stove and burden calculation, is applied. Each unit operation is described by theoretical correlations and empirical relations from industry data, as described by Hooey et al. [17] and Sundqvist et al. [18]. The model is calibrated against data obtained from SSAB Luleå, Sweden, for reference Year 2006.

Pulp and paper

The effect on the pulp mill energy system is simulated with the in-house model of a reference pulp mill described by Berglin et al. [19]. The flue gas conditions for the recovery boiler are calibrated against measurement data, and the conditions of the power boiler are based on experience acquired while operating biomass-fired CHP plants. The Pulp and paper case study is performed for a generic softwood Kraft pulp mill located on the west coast of Sweden. The equipment and performance of the pulp mill are based on the best-available technology in Year 2010.

Cement

For the Cement case, a low-level process integration is chosen for the capture plant and the effect on the operation of the cement plant is negligible. Therefore, no process simulations of the existing process are required. The flue gas conditions measured at the reference plant, Norcem Brevik in Norway, are used as input to the model of the capture process. The amount of heat recoverable for the capture process is estimated from the heat available in the hot flue gases released today.

Silicon

Similar to the Cement case, the Silicon case applies a low-level integration of the capture plant, and any effects on the present production process are not considered. The REC Solar plant in Kristiansand, Norway, is the reference case. The flue gas conditions for the capture process are derived from measurements, and the amount of heat recoverable for the capture process is estimated from the heat available in the hot gases from the furnace.

Steam generation

Steam generation is an important cost element, so its cost is assessed through a bottom-up approach. Three sources that can generate the saturated steam at 3 bar (~133°C) needed to provide heat to the reboiler are considered: excess heat recovery; a low-pressure bleed from existing steam cycles; and new boiler capacity. The cost of generating steam from excess heat is estimated by designing heat-collecting steam networks powered by heat recovery steam generators (HRSG) in the Aspen Hysys ver. 8.6 software and applying the detailed factor estimation method described below. The design of the steam generation has been described previously [20]. The cost for utilizing a turbine bleed stream to power the capture unit is dictated by the value of the electricity that could be produced by expanding the steam down to cooling water temperature in a condensing steam turbine unit. The cost for steam from new-boiler capacity is based on a bleed stream from a new bark-fired CHP plant. Besides these options, the cost of recovering excess heat from dry slag granulation and coke dry quenching are considered for the Steel case, based on data from the literature. The steam is always reduced to 3 bar and saturated, to avoid having too-high a temperature in the reboiler.

Cost Estimation

The cost estimation for the MEA-based capture unit includes capital expenditures (CAPEX) and operational expenditures (OPEX). The partial capture processes are compared with regard to their capture cost, in € per captured tonne of CO₂. The technology maturity level is high, and the CAPEX reflect an “Nth-of-kind” (NOAK) approach. The plant is assumed to be installed at an existing site (retrofit). The purchase of land, cost of piling, and additional costs for offices etc. are not considered in the calculation of CAPEX. Figure 2 gives an overview of the system and represents the details of the study, i.e. the equipment included in the cost estimation. Minor heat exchangers, pumps, and other utilities, e.g., for the washer unit, have been ignored, as they will exert little influence on the results. The CAPEX of each unit are estimated with the Aspen In-Plant Cost Estimator and adjusted to represent the installed cost with an individual installation factor. Empirical formulas from an in-house cost database [13] based on data collected from industry are used to determine the installation factors, which account

for the types and sizes of individual items of equipment and their installation depending on the type of site. This method of CAPEX estimation normally has an uncertainty of $\pm 40\%$ (80% confidence interval). The cost of steam has the strongest impact on the capture cost, followed by plant lifetime and rate of return. Therefore, specific studies of the cost of steam have been performed, [20]. The underlying economic assumptions for the cost estimation and utility costs, including steam generation, are given in Table 3 for the different cases.

Table 3. Assumptions applied for the cost estimation of the capture unit depending on the discussed industry and the steam generating unit.

Unit parameters		Capture unit				Steam generating unit
		Steel	Pulp	Cement	Silicon	
Project lifetime	years	25	25	25	25	25
Construction time	years	2	3	2	2	1
Discount rate	%	7.5	7,5	7.5	7.5	7.5
Cost level reference year		2015	2015	2015	2015	2016
Yearly operation	h/a	8,322	7,840	7,320	8,760	8,000
Maintenance (annualized)	% of CAPEX	4	4	4	4	4
Labor cost	k€/a	821	821	821	821	0
Location factor	-	1*	1*	1*	1*	1*
Utilities						
Electricity**	€/MWh	30	30	55	55	-
Green electricity premium	€/MWh	15	15	15	15	-
Cooling water	€/m ³	0.022	0.022	0.022	0.022	-
Monoethanolamine	€/m ³	1,867	1,867	1,867	1,867	-
Sludge disposal	€/tonne	333	333	333	333	-
Natural gas	€/MWh	30	30	30	30	-
Low-grade biomass	€/MWh	16	16	16	16	-
Steam***	€/tonne	16.7	16.7	16.7	16.7	-

* Generic location, e.g., Rotterdam (with excellent communications and working conditions).

** Price for electricity is taken from estimations according to the specific site.

*** Price if steam is purchased as a utility. Otherwise, the cost is estimated based on site-specific conditions.

Case Studies

This chapter includes an overview of the case studies performed within the CO₂stCap-Project. The overview includes the carbon flows through the processes, a process scheme with potential integration of the capture process, and a summary of the estimated costs of capture.

Steel

The SSAB steel mill in Luleå produces around 2 Mt of primary steel slabs per year and emits around 1.7 tonne of CO₂ per tonne of steel slabs. Figures 3 and 4 give an overview of the process layout and carbon flows at the Luleå site. The major characteristics of the SSAB plant, in relation to those of other integrated iron and steel plants, are that the blast furnace is only charged with iron ore pellets (no sinter), and that the downstream treatment of the steel slabs after casting does not take place onsite. Carbon is mainly expended on energy and iron ore reduction. The largest and, therefore, the most interesting carbon sources are the blast furnace gas, CHP plant flue gases, and hot stove flue gases. Five sources for excess heat recovery, including the use of low-pressure steam from the steam turbine, are identified at the Luleå steel mill [18]. Furthermore, the installation of new steam boiler capacity based on additional energy is considered. The sources are ranked according to their technical maturity levels and the cost for recovering heat in the form of saturated steam at 3 bar. The partial-capture processes are designed with inter-stage cooling and rich-solvent splitting, so as to cope with CO₂ concentrations ≥ 25 vol.% in the steel mill off-gases in a cost-efficient way.

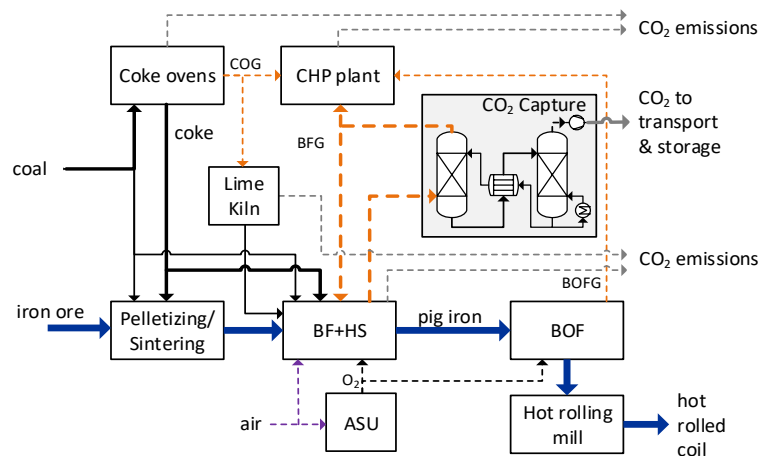

Figure 3. Illustration of the steel mill process with CO₂ capture from the blast furnace gas. Abbreviations: ASU, air separation unit; BF, blast furnace; BFG, blast furnace gas; BOF, basic oxygen furnace; BOFG, basic oxygen furnace gas; CHP, combined heat and power; COG, coke oven gas; HS: hot stoves.

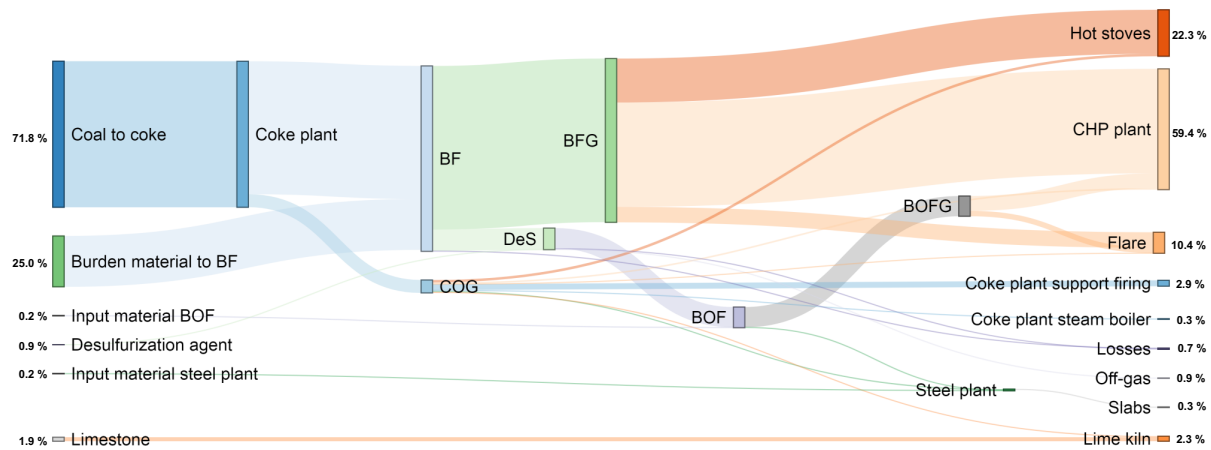

Figure 4. Carbon flows through the Luleå steel mill. Source: [21].

Capture Scenarios

Table 4 presents the investigated capture scenarios for the Luleå steel mill based on the CO₂ and heat sources developed and their maximum achievable reductions in emissions, as well as their additional fuel and power requirements. Figure 5 summarizes the results as the capture costs related to the achieved reductions in CO₂ emissions. The capture costs are in the range of 28–45 €/tonne CO₂-captured. The capture cost has a minimum in the range of capture of 1.0–1.2 Mt CO₂/a, after which more expensive heat recovery units are required. The capture cost of 28 €/tonne CO₂-captured is achieved for capture from the blast furnace gas with heat supplied from back-pressure, gas flaring, and flue gas heat recovery (FGHR), achieving a 38% reduction in site emissions (ca. 1.2 Mt CO₂/a). The full-capture scenario, i.e., - 90% capture from BFG, hot stoves- and CHP plant flue gases, comes at a capture cost of 39–54 €/tonne CO₂-captured, depending on the cost of external energy, and reduces the site emissions by 76% (ca. 2.6 Mt CO₂/annum). The cost for new steam generation is the major reason for the difference between the cost of the full-capture and partial-capture scenarios. Concerning the source of CO₂, the cost of capturing CO₂ from the blast furnace gas is, on average, 5 €/tonne CO₂ lower than end-of-pipe capture from the CHP plant. This is due to the higher pressure in the BFG, which enhances absorption and reduces the equipment size, and the increase in the specific heating value of the BFG when removing the CO₂, which allows for a more energy-efficient distribution of process gases in the steel mill, entailing more retrievable excess heat, as described previously [18].

Table 4. Overview of the investigated capture scenarios for the Luleå steel mill. Source: [21].

Capture scenario	CO ₂ source	Applied heat source	Max site reduction (% CO ₂)	Extra fuel (MJ/kg CO ₂)	Net electricity import (MJ/kg CO ₂)
HS	hot stoves flue gas	Back-pressure; FGHR	19.0	0	-0.01
BFG	blast furnace gas	Back-pressure; FGHR; Flare gases; CDQ	38.8	0	+0.07
CHP	CHP plant flue gas	Back-pressure; FGHR; Flare gases; CDQ; DSG	43.2	0	+0.09
BFG+HS	blast furnace gas plus hot stoves flue gas	Back-pressure; FGHR; Flare gases; CDQ; DSG; Bio-CHP	51.0	0.28	+0.06
BFG+HS+CHP (full capture)	blast furnace gas plus hot stoves flue gas plus CHP plant flue gas	Back-pressure; FGHR; Flare gases; CDQ; DSG; Bio-CHP	76.3	1.66	-0.15

FGHR, flue gas heat recovery; CDQ, coke dry quenching; DSG, dry slag granulation; Bio-CHP, biomass-fired combined heat and power plant; HS: hot stoves; BFG, blast furnace gas.

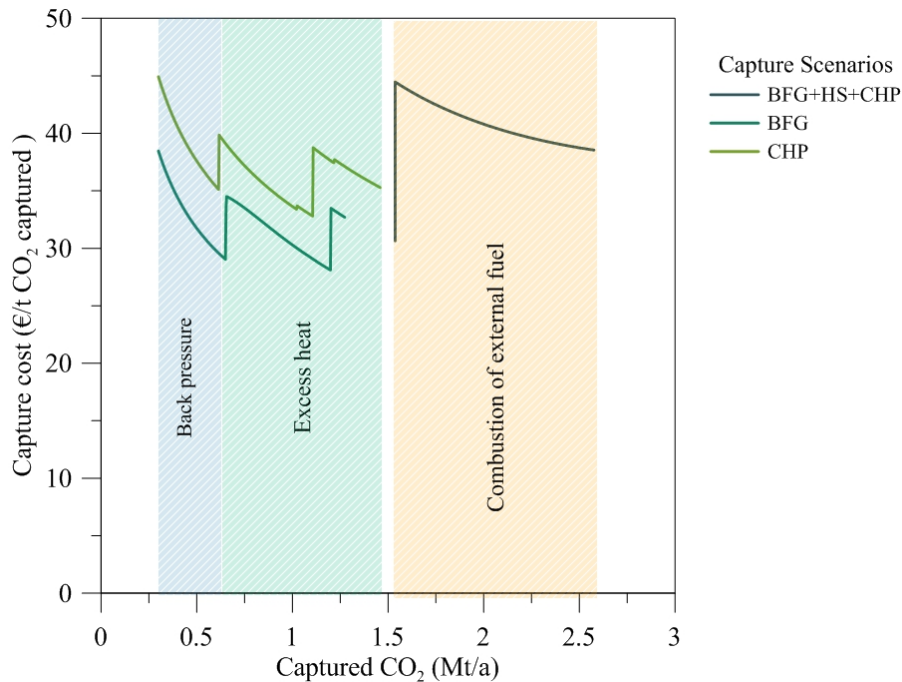

Figure 5. CO₂ capture cost from the SSAB steel mill in Luleå in relation to the amount of captured CO₂. The lines represent scenarios that depend on which sources are considered (*cf.* Table 4). The colored fields in the background show which heat sources are utilized, deployed in the order of: back pressure (extraction from the steam turbine); excess heat (FGHR, flare gases, CDQ, DSG); and combustion of an external fuel. Adapted from [21].

Pulp and Paper

The Kraft pulp mill process is illustrated in Figure 6, and its carbon balance without carbon capture is presented in Figure 7. The mill has a nominal design capacity of 700,000 air dry tonne of pulp per year (ADt/a) in a single production line. The pulping process is based on softwood. The mill has three major CO₂ emissions sources: the recovery boiler, lime kiln, and power (or bark) boiler. The lime kiln is operated with bark powder. Fossil fuels are only used to support operation during special conditions and during start-up. The bark that remains after the refining process is fired in a power boiler to generate steam for the pulping process and to generate electricity in a steam turbine. The recovery boiler, which is the major boiler at the site, is required to regenerate the black liquor from the cooking process. In the recovery boiler, the lignin from the wood (contained in the black liquor) is combusted and the released heat is used for steam and electricity generation. The mill does not deliver any district heating. The steam needed in the stripper reboiler may be extracted from the existing low-pressure (LP) steam extraction (at 4.5 bar) from the steam cycle or generated in an additional bark boiler. In a modern well-heat-integrated mill, such as the one studied here, there is no excess heat at the required temperatures. The cost of steam is, thus, reflected as either a loss in electricity generation or in the required investment and operational costs of a new bark boiler.

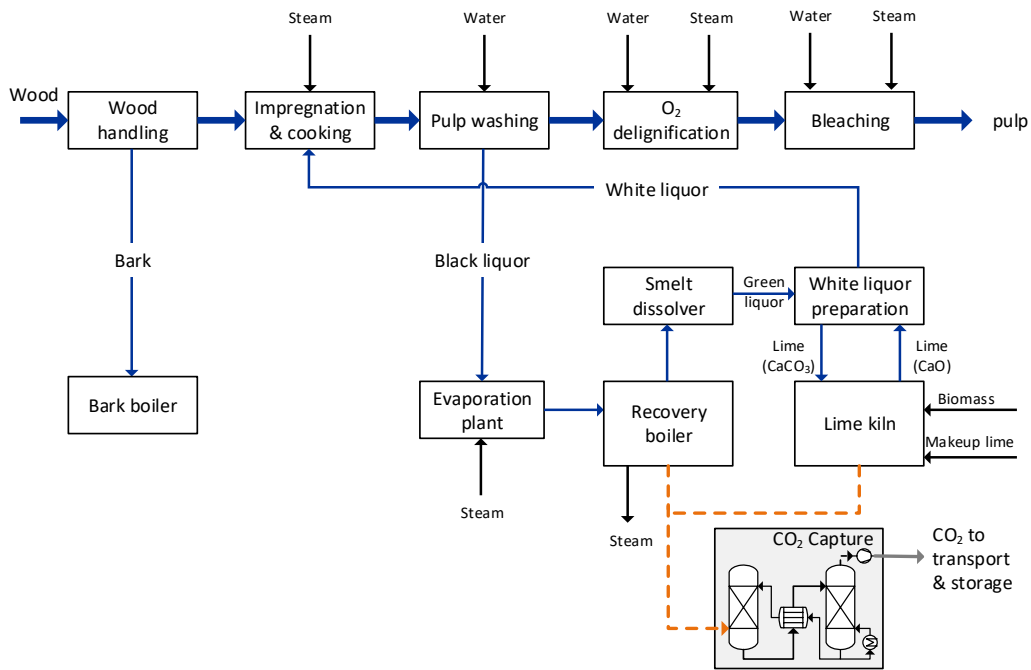

Figure 6. Illustration of the processes in a Kraft pulp mill with an integrated CO₂ capture unit.

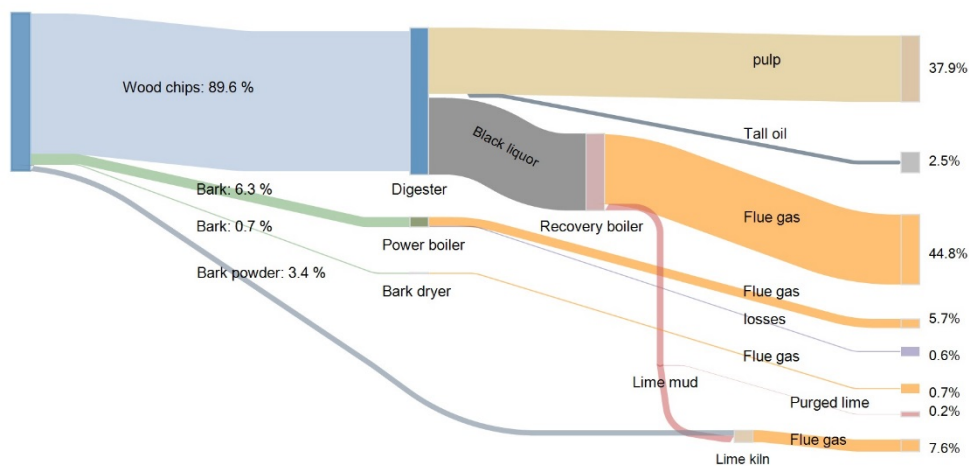

Figure 7. Carbon flow through a Kraft pulp mill without an integrated CO₂ capture unit.

Capture Scenarios

At the pulp mill, CO₂ capture from the recovery boiler and the lime kiln is preferable, as the CO₂ concentration is somewhat lower in the bark boiler and, particularly, as the bark boiler is the smallest source and is not run continuously, being instead used to cover seasonal and daily variations in the steam demand. Although the lime kiln is a much smaller source than the recovery boiler, it is favored by a higher concentration of CO₂, which is why a capture rate of 95% (instead of 90%) is considered as full capture for the lime kiln. The investigated capture scenarios including the achieved capture rates, amounts of additional bark required, and loss of power production compared to the reference case are summarized in Table 5.

Table 5. Overview of the investigated capture scenarios for the pulp mill.

Capture scenario	CO ₂ source	Applied heat source	Site reduction (% CO ₂)	Extra fuel (MJ/kg CO ₂)	Net electricity import (MJ/kg CO ₂)
RB-LP	Recovery boiler	LP-steam	66.5	-	-0.44
RB-LP+BB	Recovery boiler	LP-steam, Bio-CHP	67.6	0.57	-0.33
LK+RB-LP+BB	Lime kiln + Recovery boiler	LP-steam, Bio-CHP	74.0	1.25	-0.20

RB, recovery boiler; LK lime kiln; LP, existing low-pressure steam extraction; BB, bark boiler; Bio-CHP, biomass-fired combined heat and power plant.

Figure 8 presents the capture costs for the pulp mill in relation to the amount of CO₂ captured. The cases investigated for the pulp mill result in a specific cost for CO₂ capture that lies in the range of 41–54 €/tonne CO₂-captured. The lowest cost is achieved by extracting steam from the existing steam network, i.e., utilizing steam that is otherwise expended for power generation to capture CO₂ from the recovery boiler. The available LP steam is sufficient to capture around 0.9 Mt CO₂/a. To achieve full capture from the recovery boiler (1.1 Mt/a) and the lime kiln (a total of 1.2 Mt/a), additional steam generation is required, which increases the capture cost to 51 €/tonne and 54 €/tonne, respectively. Capture from the lime kiln is more costly than capture from the recovery boiler, as even though the CO₂ concentration is higher, the quantity of CO₂ is lower. In the case of an additional bark boiler, electricity generation can be boosted by expanding the high-pressure (HP) steam through a turbine. The estimated capture cost is sensitive to the value of the electricity (including any green electricity premium) and of the bark considered as a fuel, as the steam generated for the capture process is extracted from a steam cycle.

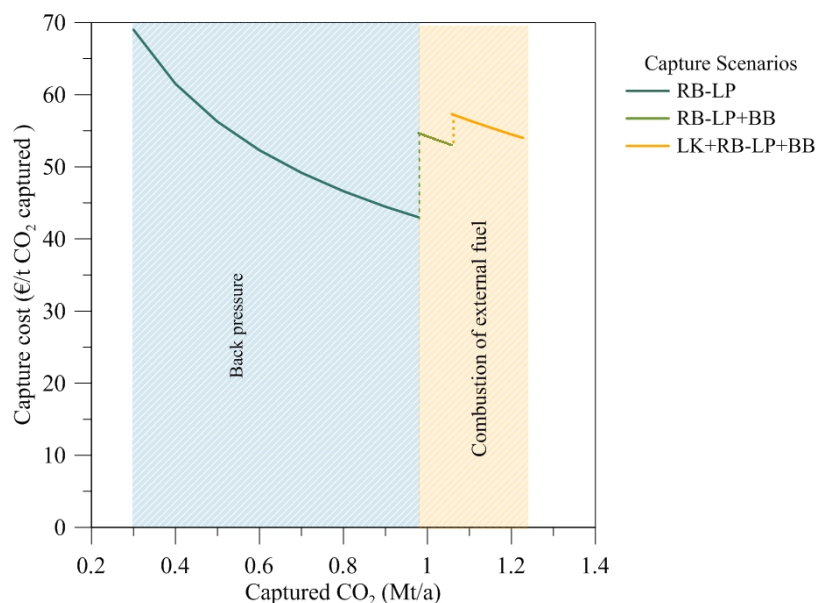

Figure 8. CO₂ capture costs from the pulp mill for the different scenarios in relation to the level of CO₂ captured annually. The lines represent scenarios that relate to the sources considered (*cf.* Table 5). The colored fields in the background show the heat sources that are utilized – deployed in the order of back pressure and combustion of external fuel.

Cement

Norcem Brevik is a medium-sized cement plant, from a Nordic perspective, with an annual production capacity of around 1 Mt of clinker and 1.2 Mt of cement. In 2016, the total CO₂ emissions were reported as 840 kt, of which 98 kt were of biogenic origin. The layout of the process and the integration of the capture unit are illustrated in Figure 9, and the carbon balance of the plant without capture is shown in Figure 10. The CO₂ emissions are from the calcination process and the combustion of fuels for heating of the material. All emissions are collected in a single stack. The Norcem cement plant is different from other cement plants in having relatively high levels of excess heat at temperatures that are sufficient for powering a carbon capture process. The plant does not presently have a steam cycle, and additional steam generation using an external fuel would be required for full capture. The Norcem Brevik cement plant is part of the ongoing Norwegian full-scale CCS project, where the goal is to have at least one complete CCS chain in operation by 2022 [22].

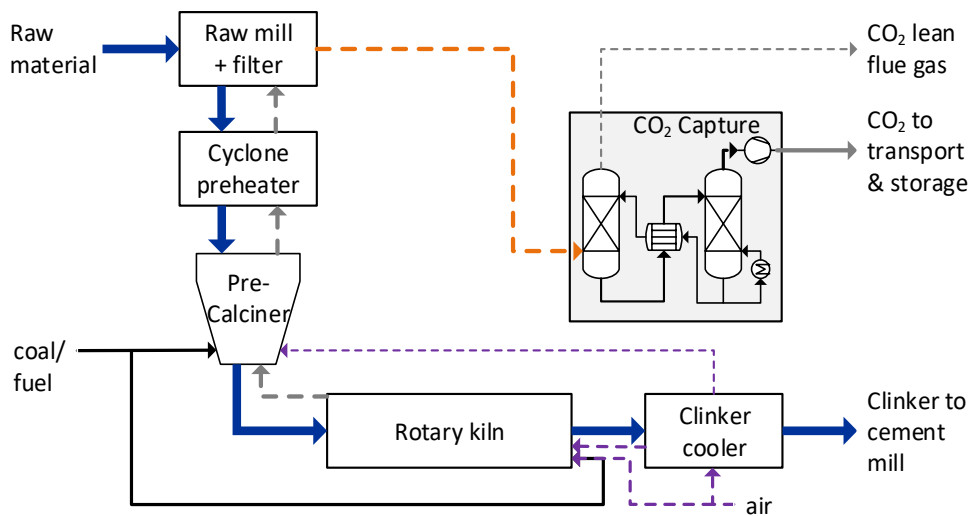

Figure 9. Process overview of the Norcem cement plant including the integration of a CO₂ capture plant.

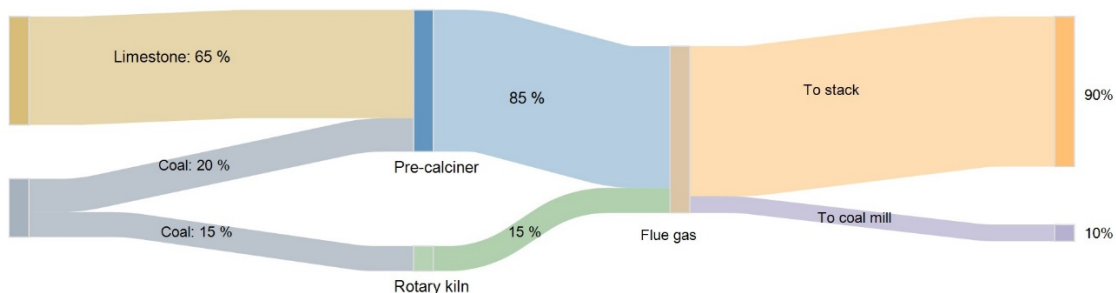

Figure 10. Carbon flows through the Norcem cement plant without an integrated CO₂ capture unit.

Capture Scenarios

An overview of the capture scenarios investigated are presented in Table 6. As there is only one source of emissions at the site, the differences between the cases relates to the generation of the heat required. The heat in the warm flue gases is estimated to be able to generate 33 MW of steam at 3 bar in a HRSG. In the partial capture case, as much CO₂ as possible is captured utilizing this excess heat. To achieve higher capture rates, investment in new steam generation capacity is required. Figure 11 shows the capture cost as a function of the amount of CO₂ captured. The specific CO₂ capture cost for the Cement case is in the range of 50–55 €/tonne CO₂-captured. The lower end of the cost range is achieved by only capturing with the heat supplied from the HRSG, which results in a capture rate of 37%. Full capture, supported by new steam generation capacity, comes at a cost of 55 €/tonne

CO₂-captured, which can be compared with 63 €/tonne CO₂ for full capture if no excess heat would have been available.

It should be noted that oxy-fuel combustion has been shown to be beneficial for cement plants. Even though oxy-fuel combustion is not able to utilize the low-value excess heat from the cement process, the CO₂ from the calcination process does not need to be separated in this case as the gas separation is performed before the combustion. The performance of oxy-fuel combustion is, however, more uncertain than that of the more mature MEA-based capture process and is not discussed further here – more information on the studies of oxy-fuel combustion within the project may be found elsewhere [23].

Table 6. The investigated capture scenarios for the Cement plant.

Capture scenario	CO ₂ source	Applied heat source	Max. site reduction (% CO ₂)	Extra steam (MJ/kg CO ₂)
Ref. F	Stack	Bio-CHP	90.0	3.22
F	Stack	FGHR; Bio-CHP	90.0	1.96
P1	Stack	FGHR	37.0	0

FGHR, flue gas heat recovery; Bio-CHP, biomass-fired combined heat and power plant.

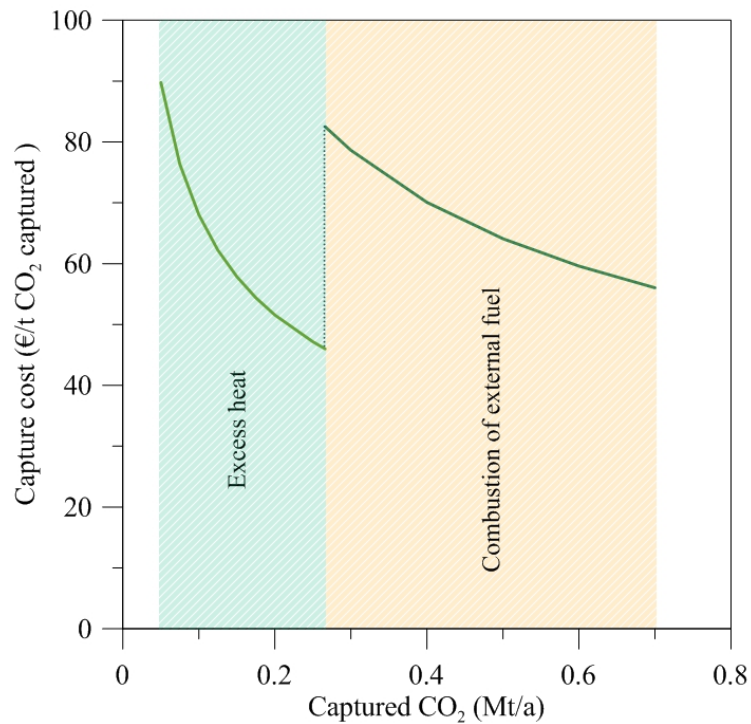

Figure 11. Cost of CO₂ capture from the cement plant for the partial capture scenario depending on the level of annually captured CO₂. The colored fields in the background indicate which heat sources are utilized – deployed in the order of excess heat (FGHR) and combustion of external fuel.

Silicon

The REC Solar plant in Kristiansand, Norway, with a yearly production around 10 kt of silicon is used as a reference plant for silicon manufacturing. The process layout of the silicon plant with the integrated capture unit is shown in Figure 12, and the plant carbon balance without capture is given in Figure 13. The CO₂ emissions are 55 kt/a - around 80% fossil carbon and 20% from bio-based sources – and are highly diluted with air. The relatively low level of emission of 55 kt CO₂/a and low off-gas concentration makes the REC Solar plant an emissions source that would normally not be considered for capture. However, in line with the partial capture concept, this project evaluates small but low-cost sources of CO₂, and the considerable amount of excess heat at REC Solar makes this an interesting source.

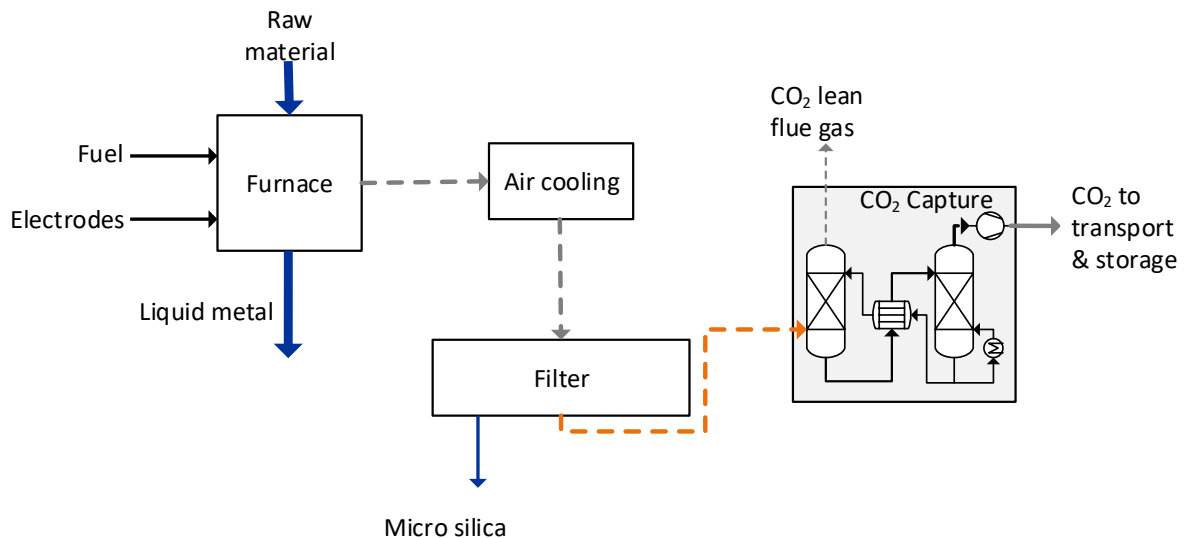

Figure 12. Illustration of the silicon plant at REC Solar and the integration of the capture plant.

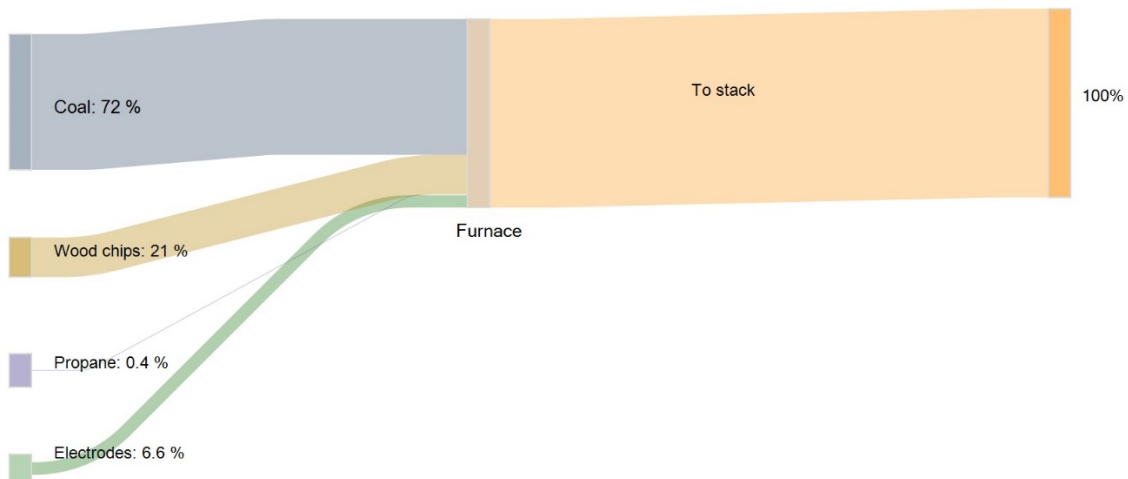

Figure 13. Carbon balance of the REC Solar plant without carbon capture.

Capture Scenarios

The REC Solar plant is different from the other cases included in the CO₂stCap-Project in that it is possible to enable full capture through utilizing only the available excess heat, and there are no benefits associated with decreasing the capture rate. The excess heat is in the form of warm off-gases, which are recovered in the HRSG. Even though no additional heat is needed for the process, owing to the small amounts and low concentrations of CO₂ in the off-gases, the cost for capture is high, at around 125 €/tonne CO₂-captured. Thus, the capture cost is

in this case dominated by the investment and maintenance costs. For comparison, if new steam generation capacity would be required, the capture cost would be around 150 €/tonne CO₂-captured.

Table 7. The investigated capture scenarios for the Silicon plant.

Capture scenario	CO ₂ source	Applied heat source	Max. site reduction (% CO ₂)	Extra steam (MJ/kg CO ₂)
Ref. F	Stack	Bio-CHP	90.0	3.53
F	Stack	FGHR	90.0	0

FGHR, flue gas heat recovery; Bio-CHP, biomass-fired combined heat and power plant.

Results

In this chapter, the insights from the four case studies on partial capture presented above are generalized to show: 1) the potential impact of partial capture on the CO₂ abatement from the industrial sector; 2) the importance for the cost of capture of the site energy system and the possibilities for steam generation; and 3) a discussion as to how partial capture affects the cost structure of CCS and the relationship to the product manufacturing cost.

System Impacts of Partial Capture

To illustrate the potential of partial capture to reduce carbon emissions from the industrial sector, the Swedish sites with large emissions (>500 kt CO₂/a) are used. Figure 14 illustrates the potential as a marginal abatement cost curve (MACC) for applying full and partial carbon capture to these sites. The cost of applying full capture to these sources without considering the site-specific energy system has previously been presented by Gardarsdottir et al. [24] (green lines in Figure 14). As discussed by Gardarsdottir et al., the cost range of 40–120 €/tonne CO₂ for full capture is broad, although not surprising given the heterogeneity of the sources considered. In general, the size of the source has the greatest impact on the full capture cost, and the large stacks at the large sites are those with the lowest capture cost. Considering only the most suitable stacks at the largest sites reveals the potential to capture around 20 Mt/a for a cost of less than 70 €/tonne.

The Chalmers industrial database [7], which includes an estimate of the excess heat available at Swedish industrial sites, is applied to estimate the effect of applying excess heat to drive carbon capture. For simplicity, the excess heat potential is assessed as either 0 or 1 MJ/kg CO₂-emitted. The yellow dotted curve in Figure 14 shows the effect on the cost of applying excess heat to lower the cost of steam generation in applying full capture at these sites. However, as new steam generation capacity is required in all the cases, the impact on the capture cost is limited. Applying the concept of partial capture to capture only the amount of CO₂ that is possible without investment in new steam capacity to the estimated availability of excess heat generates the full green curve in Figure 14. Using excess heat-driven partial capture, it is possible to capture around 5 Mt of CO₂ per year to a cost of 20–45 €/tonne CO₂ from the Swedish industrial sector. It should be noted that many of the sources to which partial capture is applied are those with a relatively low cost also for full capture. Nevertheless, the results show that a considerable amount of the CO₂ in the energy system could be captured at low cost.

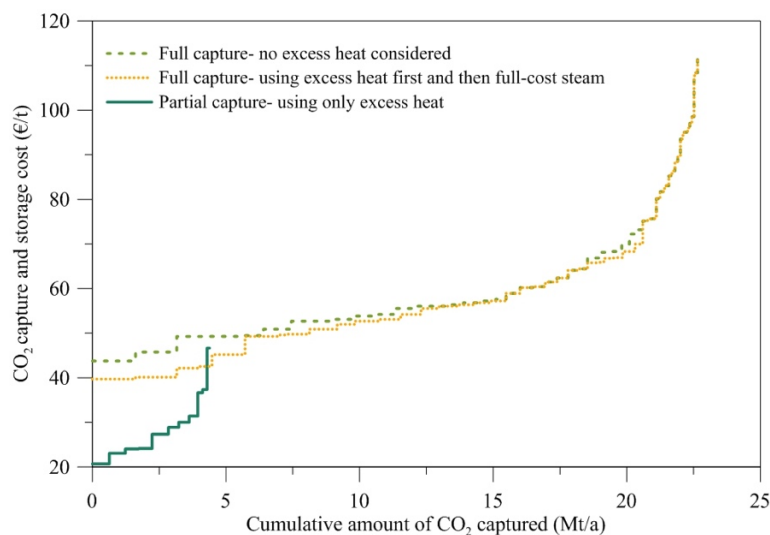

Figure 14. Marginal abatement cost curve for carbon capture from Swedish emission sources of >500kt CO₂/a. The effects of excess heat and partial capture on capture costs are shown. The green dashed line represents full capture using only full-cost steam. The yellow dotted line represents full capture using available excess heat and full-cost steam. The full green line represents partial capture of CO₂ that can be captured only by utilizing excess heat.

Cost of Steam Generation

The analysis of the partial capture concept reveals the generation of steam from excess heat to be the main driver for reducing the capture cost. The heat requirement for solvent regeneration is a considerable heat sink at the reboiler temperature, typically around 120°C, and it will consume the available excess heat above this temperature for more or less all industrial processes. The project has placed special emphasis on establishing a method to estimate the cost of generating the steam required from various heat sources [20]. Figure 15 shows the cost of steam generation for carbon capture depending on the relationship between the amount of steam generated and the amount of CO₂ emitted at each of the four industrial sites studied in the CO₂stCap-Project. The cost of steam generation is estimated for excess heat sources, including back-pressure steam from existing steam cycles, hot flue gases, flare gases, dry slag granulation, and coke dry quenching, as well as for new steam boiler capacity. The energy sources are sorted in ascending order, forming a stair function for the generated cost where each step in the curve represents the change in the cost of steam when proceeding to the next heat level, i.e., as one additional source is deployed. The cost of steam from excess heat is in the range of 2–10 €/MWh, which should be compared to the cost of a new steam boiler, which is around 20 €/MWh. The results show that the cost of steam is highly site-specific, and that most industrial energy systems have capacities that are far below those required to power full CO₂ capture, so they require new steam generation capacity (e.g., to increase the steam/heat output in an existing facility or the installation of a new steam boiler).

MEA-based carbon capture processes typically require around 3 MJ/kg CO₂-*separated*. Thus, 3 MJ/kg CO₂-*emitted* is approximately the amount of steam required for full capture. Staying at a certain heat level with a lower cost but also amount of heat per CO₂-*emitted* implies partial capture to the achievable capture rate. It is, however, likely that the specific heat requirement of the capture process will be lowered by improvements in process or solvent design, which means that the capture rate will increase as the process evolves. Processes that are based on proprietary solvents that outperform the pure MEA used in the present study are already readily available on the market.

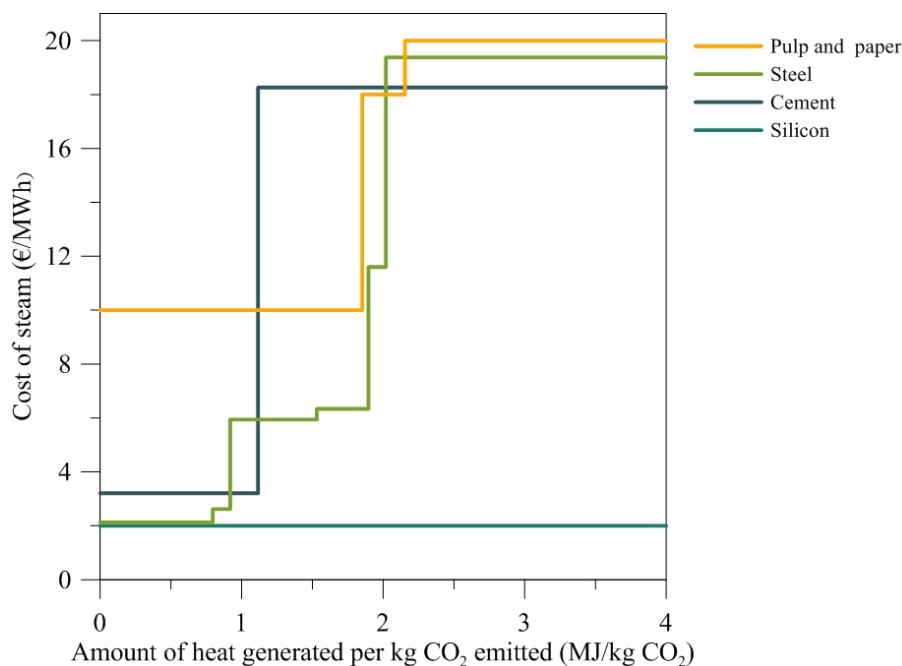

Figure 15 – Cost of steam generation at the investigated industrial sites considering the existing energy system, expressed relative to the amount of steam extracted per kg of CO₂ emitted.

Cost Structure of Partial Capture

Figure 16 shows the specific cost for capture divided into CAPEX and OPEX and with the steam cost share of the total specific cost indicated. On the one hand, maintenance costs, which are estimated to be proportional to the investment, make up the main part of the OPEX. On the other hand, the cost for steam dominates the running costs of the process. The Silicon case clearly requires a high specific investment, as the amount of CO₂ emitted is relatively small, which does not make it competitive, from this point of view, relative to the other cases. For the other cases, it is clear that the relative importance of the running cost (generation of steam) is decreased for partial capture when the specific investment increases due to decreased captured level of CO₂, and/or when excess heat is used for steam generation. Partial capture is, therefore, less sensitive to uncertainties and fluctuations in energy prices.

Figure 17 relates the cost of implementing CO₂ capture to the cost of the products generated in the four industrial cases. It should be noted that the figure is made without considering any penalties for emitting CO₂. If the emission penalty exceeds the capture cost there will be a value (rather than a cost) associated with implementing carbon capture. Apart from possibly recovering value by selling off emissions allowances, which have been freely allocated to the plant owners, or simply avoiding having to pay for the emissions, funding mechanisms could foresee the passing-on of emissions allowances generated by removing CO₂ from the atmosphere, as an income to create value for bio-energy with CCS or direct air capture.

Yet another way to valorize the increase in production cost from CCS is to shift the price down the value chain to the consumer of the end-product, as proposed by Rootzén and Johnsson [25]. For example, they showed that the increase in retail price of a mid-sized European passenger car would be <0.5% based on a cost increase of 50 €/tonne steel, which is in line with the cost added by carbon capture. The likelihood that the industrial stakeholder will tolerate the additional cost of carbon capture will be dictated by how competitive the sector is and how large are the profit margins for the sold products. It seems likely that several funding mechanisms will be required to facilitate the implementation of markets for low-carbon products.

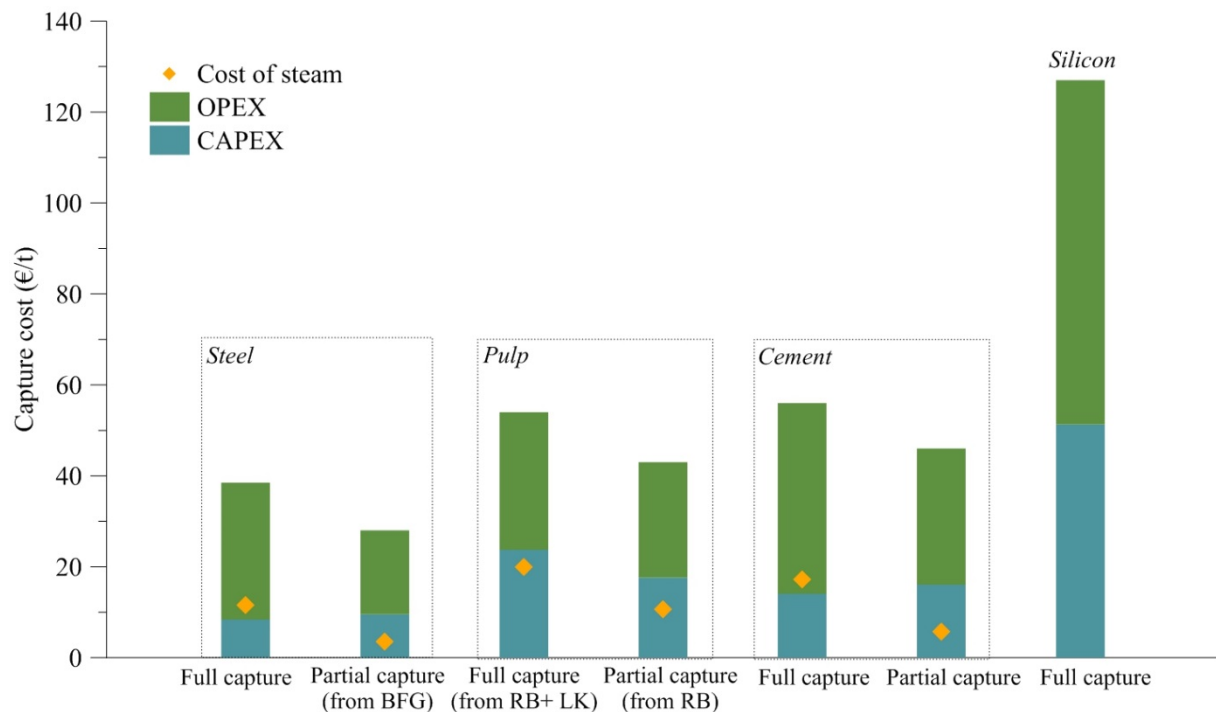

Figure 16. CO₂ capture cost divided into CAPEX and OPEX and with the cost of steam indicated for the four case studies of the CO₂stCap-Project. BFG, blast furnace gas; RB, recovery boiler; LK, lime kiln.

b)

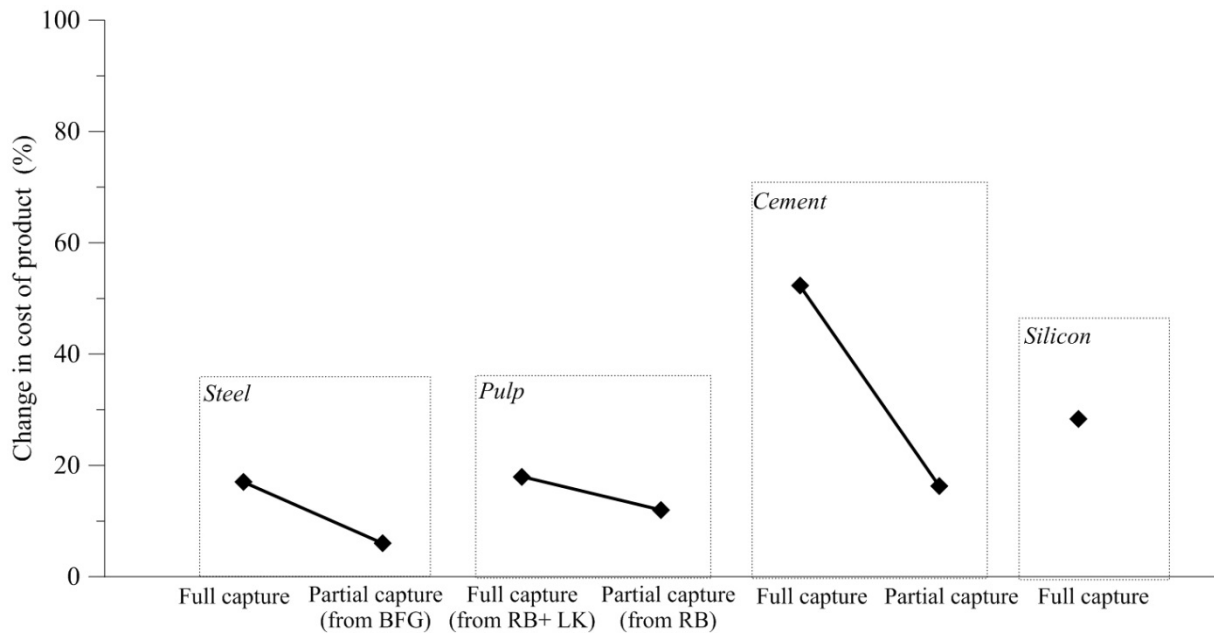

Figure 17. Illustration of the relative increase in the cost of the product resulting from the implementation of carbon capture. Note that no penalty for emitting CO₂ is considered. For the Steel case, the required relative increase in production cost to cover the capture cost is based on the estimated production cost of 280 €/tonne of steel slab [26]. For the Pulp and paper case, the increase in price is calculated based on the pulp market price of 750 €/ADt [27]. For the Cement case, the calculation is based on the production cost of 62 €/tonne [28], and for the Silicon case, it is based on the cost of 1600 €/tonne for silica. BFG, blast furnace gas; RB, recovery boiler; LK, lime kiln.

Conclusion

The CO₂stCap Project has since Year 2015 worked to develop methodologies for cost estimation and process evaluation that facilitate the design of cost-efficient carbon capture processes, with the focus on partial capture. The project has shown that by focusing on the most-cost-effective CO₂ sources, partial capture can reduce considerably both the specific and the absolute CO₂ capture costs. The *reduction of the specific cost* is important to motivate the operation of carbon capture, given that this cost is related to the cost of allowances for emitting CO₂ and, therefore, could create value for CCS. The *reduction of the absolute cost* is important in terms of reducing the risk of the investment, which is especially important for early adopters and during the maturation of the carbon markets.

More specifically, the project has performed case studies that deal with the implementation of cost-efficient carbon capture in four Nordic industries: Cement, Steel, Pulp, and Silicon production. The results demonstrate the potential for cost-efficient partial capture of CO₂ at all these industrial sites. In summary, the plants investigated could capture 100–500 kt/a each by utilizing the excess heat and low-pressure steam available at the sites at a cost of 40–70 €/tonne CO₂, with the steel and cement plants having the lowest costs. This can be compared to the 80–110 €/tonne CO₂ required for full capture.

References

1. IEA, *World Energy Outlook*. 2018. p. 1-643.
2. HYBRIT. *Summary of Findings from HYBRIT Pre-Feasibility Study 2016–2017*. [cited 2018 25/7]; Available from: <http://www.hybritdevelopment.com>.
3. Eurofer, *A steel roadmap for a low carbon Europe 2050*, in 2013, Eurofer, The European Steel Association.
4. Fishedick, M.M., J.; Winzer, P.; Weigel, M. , *Techno-Economic Evaluation of Innovative Steel Production Technologies*. *J. Clean. Prod.* , 2014. **84**(1): p. 563–580.
5. Goodrich, A., T. James, and M. Woodhouse, *Residential, Commercial, and Utility-Scale Photovoltaic (PV) System Prices in the United States: Current Drivers and Cost Reduction Opportunities*. 2012, NREL: Golden, Colorado.
6. SEPA, *National Inventory Report Sweden 2018*, Swedish Environmental Protection Agency: Stockholm, Sweden.
7. Svensson, E., et al., *Chalmers Industrial Case Study Portfolio*. 2019, Chalmers University of Technology: Göteborg, Sweden.
8. Rao, A.B. and E.S. Rubin, *Identifying Cost-Effective CO₂ Control Levels for Amine-Based CO₂ Capture Systems*. *Ind. Eng. Chem. Res.* , 2006. **45**(8): p. 2421–2429.
9. Bains, P., P. Psarras, and J. Wilcox, *CO₂ Capture from the Industry Sector*. *Prog. Energy Combust. Sci.*, 2017. **63**: p. 146–172.
10. Gardarsdóttir, S.Ó., et al., *Post combustion CO₂ Capture Using Monoethanolamine and Ammonia Solvents: The Influence of CO₂ Concentration on Technical Performance*. *Ind. Eng. Chem. Res.* , 2015. **54**(2): p. 681-690.
11. Biermann, M., et al., *Partial Carbon Capture by Absorption Cycle for Reduced Specific Capture Cost*. *Ind. Eng. Chem. Res.*, 2018. **57**(45).
12. Eldrup, N.H., et al., *A Cost Estimation Tool for CO₂ Capture Technologies*, in *14th Greenhouse Gas Control Technologies Conference 2018*: Melbourne, Australia.
13. van der Spek, M., et al., *Unravelling uncertainty and variability in early stage techno-economic assessments of carbon capture technologies*. *Int. J. Greenh. Gas Con.*, 2017. **56**: p. 221-236.
14. Abu-Zahra, M.R.M., et al., *CO₂ capture from power plants: Part I. A parametric study of the technical performance based on monoethanolamine*. *Int. J. Greenh. Gas Con.*, 2007. **1**(1): p. 37-46.
15. Gardarsdóttir, S.Ó., et al., *Postcombustion CO₂ Capture Using Monoethanolamine and Ammonia Solvents: The Influence of CO₂ Concentration on Technical Performance*. *Industrial & Engineering Chemistry Research*, 2015. **54**(2): p. 681-690.
16. Le Moullec, Y., et al., *Process modifications for solvent-based post-combustion CO₂ capture*. *Int. J. Greenh. Gas Con.*, 2014. **31**: p. 96-112.
17. Hooley, P.L., et al., *Design and Application of a Spreadsheet-based Model of the Blast Furnace Factory*. *ISIJ International*, 2010. **50**(7): p. 924-930.
18. Sundqvist, M., et al., *Evaluation of Low and High Level Integration Options for Carbon Capture at an Integrated Iron and Steel Mill*. *Int. J. Greenh. Gas Control*, 2018. **77**: p. 27-36.
19. Berglin, N., et al., *The 2010 Reference Mill for Kraft Market Pulp*, in *PEERS Conference*. 2011: Portland, Oregon.
20. Ali, H., et al., *Cost estimation of heat recovery networks for utilization of industrial excess heat for carbon dioxide absorption*. *Int. J. Greenh. Gas Control*, 2018. **74**(219-228).
21. Biermann, M., et al., *Heat Driven Carbon Capture at an Integrated Steel Mill – Considerations for Capture Cost Optimization*. 2019: Submitted for Publication.
22. Gassnova. *The Full-scale CCS project in Norway*. [cited 2019 25/7]; Available from: <https://ccsnorway.com>.
23. Mathisen, A. and R. Skagestad, *CO₂ capture scenarios for a cement plant*. Submitted for publication, 2019.
24. Gardarsdóttir, S.Ó., et al., *Investment costs and CO₂ reduction potential of carbon capture from industrial plants – A Swedish case study*. *Int. J. Greenh. Gas Con.*, 2018. **76**: p. 111-124.
25. Rootzén, J. and F. Johnsson, *Paying the Full Price of Steel – Perspectives on the Cost of Reducing Carbon Dioxide Emissions from the Steel Industry*. *Energy Policy*, 2016. **98**: p. 459-469.
26. IEAGHG, *Iron and Steel CCS Study (Techno-Economics Integrated Steel Mill)*. 2013, IEAGHG: Cheltenham.
27. *IndexMundi*. [cited 2019 25/7]; Available from: <https://www.indexmundi.com>.
28. Rootzén, J. and F. Johnsson, *Managing the costs of CO₂ abatement in the cement industry*. *Climate Policy*, 2017. **17**(6): p. 781-800.



IEA Greenhouse Gas R&D Programme

Pure Offices, Cheltenham Office Park, Hatherley Lane,
Cheltenham, Glos. GL51 6SH, UK

Tel: +44 1242 802911

mail@ieaghg.org
www.ieaghg.org